

DEPARTMENT OF THE ARMY TECHNICAL MANUAL

**OPERATOR'S, ORGANIZATIONAL,
DIRECT SUPPORT, AND GENERAL SUPPORT
MAINTENANCE MANUAL**

RADIO SET AN/GRC-109

(NSN 5820-00-892-0881:)

**This copy is a reprint which includes current:
pages from Changes 4 through 6.'**

**HEADQUARTERS, DEPARTMENT OF THE ARMY
18 MAY 1962**

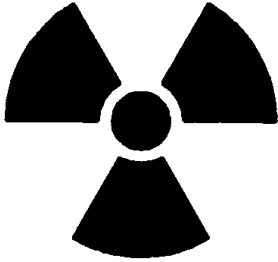
RADIATION HAZARD

STD-RW-2

Tube type OB2 used in this radio set contains radioactive material. This tube is potentially hazardous when broken: see qualified medical personnel and the safety director if you are exposed to or cut by broken tubes. Use extreme care in replacing these tubes (para 87) and follow safe procedures in their handling, storage, and disposal (para 38.3)

Never place radioactive tubes in your pocket. Use extreme care not to break radioactive tubes while handling them. Never remove radioactive tubes from cartons until ready to use them. Refer to paragraph 38.3 on handling, storage, and disposal of radioactive material.

WARNING**DANGEROUS VOLTAGES EXIST IN THIS EQUIPMENT**

Be extremely careful when servicing the power supplies and transmitter; voltage above 450 volts may be present. Take care not to contact the ac power source when connecting power supplies; voltages up to 260 may be encountered.

WARNING

When selenium rectifiers fail because of burnout or arc-over, poison fumes and component fumes and compounds are released. The fumes have a strong odor and must not be inhaled. Provide adequate ventilation immediately and do not handle the rectifier until it has cooled.

DON'T TAKE CHANCES!

OPERATOR'S, ORGANIZATIONAL, DIRECT SUPPORT AND GENERAL SUPPORT

MAINTENANCE MANUAL

RADIO SET AN/GRC-109

(NSN 5820-00-892-0881)

| | | Paragraph | Page |
|---------|--|-----------|----------|
| CHAPTER | 1. INTRODUCTION | | |
| Section | I. General | 1, 2 | 3 |
| | II. Description and data | 3 - 10 | 3 - 10 |
| CHAPTER | 2. INSTALLATION | 11 - 15 | 11 - 15 |
| | 3. OPERATING INSTRUCTIONS | | |
| Section | I. Operating controls and indicators | 16, 17 | 17 |
| | II. Operation under usual conditions | 18 - 26 | 20 - 22 |
| | III. Operation under unusual conditions | 27 - 29 | 23 |
| CHAPTER | 4. OPERATOR'S MAINTENANCE | 30 - 34 | 24 - 26 |
| | 5. SECOND ECHELON MAINTENANCE | 35 - 40 | 31 |
| | 6. THEORY | | |
| Section | I. Theory of Radio Transmitter T-784/GRC-109 | 41 - 46 | 34, 35 |
| | II. Theory of Radio Receiver R-1004/GRC-109 | 47 - 53 | 36 - 38 |
| | III. Theory of Power Supply PP-2684/GRC-109 | 54 - 58 | 39 - 42 |
| | IV. Theory of Power Supply PP-2685/GRC-109 | 59, 60 | 42 |
| CHAPTER | 7. TROUBLESHOOTING | | |
| Section | I. General troubleshooting techniques | 61 - 63 | 44, 45 |
| | II. Troubleshooting Radio Receiver R-1004/GRC-109 | 64 - 69 | 45 - 56 |
| | III. Troubleshooting Radio Transmitter T-784/GRC-109 | 70 - 75 | 56, 57 |
| | IV. Troubleshooting Power Supply PP-2684/GRC-109 | 76 - 80 | 63 - 65 |
| | V. Troubleshooting Power Supply PP-2685/GRC-109 | 81 - 84 | 69, 70 |
| | VI. Troubleshooting Voltage Regulator CN-690/GRC-109 | 85, 86 | 73 |
| CHAPTER | 8. REPAIRS AND ALIGNMENT | 87 - 92 | 75 - 77 |
| | 9. FOURTH ECHELON TESTING PROCEDURES | 93 - 107 | 78 - 105 |
| APPEND | I. REFERENCES | | 108 |
| | II. MAINTENANCE ALLOCATION | | 109 |
| | III. BASIC ISSUE ITEMS LIST | | 113 |
| INDEX | | | 135 |



Figure 1. Radio Set AN/GRC-109 in operation.

CHAPTER 1

INTRODUCTION

Section I. GENERAL

1. Scope

This manual contains instructions for the installation, operation, maintenance, and repair of Radio Set AN/GRC-109 (fig. 1). It also includes three appendixes which list references, the basic issue items list and items troop installed or authorized list, and maintenance allocation.

1.1. Indexes of Publications

a. *DA Pam 310-4.* Refer to the latest issue of DA Pam 310-4 to determine whether there are new editions, changes, or additional publications pertaining to the equipment.

b. *DA Pam 310-7.* Refer to DA Pam 310-7 to determine whether there are modification work orders (MWO's) pertaining to the equipment.

2. Forms and Records

a. *Reports of Maintenance and Unsatisfactory Equipment.* Maintenance forms, records, and reports which are to be used by maintenance personnel at all maintenance levels are listed in and prescribed by TM 38-750 (Army).

b. *Report of Packaging and Handling Deficiencies.* Fill out and forward DD Form 6 (Packaging Improvement Report) as prescribed in AR 700-58/NAVSUPINST 4030.29.: AFR 71-13./MCO P4030.29A, and DLAR 4145.8.

c. *Discrepancy in Shipment Report (DISREP) (SF 361).* Fill out and forward Discrepancy in Shipment Report (DISREP) (SF 361) as prescribed in AR 55-38/NAVSUPINST 4610.33B/ AFR 75-18/MCO P4610.19C, and DLAR 4500.15.

2.1. Destruction of Army

Materiel Demolition and destruction of electronic equipment will be under the direction of the commander and in accordance with TM 750-244-2.

2.2. Administrative Storage

Prior to or after an administrative storage period, perform the maintenance procedures contained in paragraphs 31 through 33.

2.3. Reporting of Errors

Report of errors, omissions, and recommendations for improving this publication is authorized and encouraged. Reports should be submitted on DA Form 2028 (Recommended Changes to Publications and Blank Forms) and forwarded direct to Commander, US Army Communications and Electronics Materiel Readiness Command, ATTN: DRSEL-MA-Q, Fort Monmouth, NJ 07703.

2.4. Reporting Equipment Improvement Recommendations (EIR)

EIR's will be prepared using DA Form 2407, Maintenance Request. Instructions for preparing EIR's are provided in TM 38-750, the Army Maintenance Management System. EIR's should be mailed direct to Commander, US Army Communications and Electronics Materiel Readiness Command, ATTN: DRSEL-MA-Q, Fort Monmouth, NJ 07703. A reply will be furnished direct to you.

Section II. DESCRIPTION AND DATA

3. Purpose and Use

a. Radio Set AN/GRC-109 is a compact, portable radio station used for continuous wave (cw) communications, at distances up to 75 miles, under a wide range of climatic conditions. Two power supplies

and a voltage regulator permit operation from a variety of power sources.

b. Only cw signals can be transmitted, but amplitude-modulated (am) voice and tone signals as well as cw signals can be received. Transmissions

can be made by use of a built-in hand key, an external hand key, or an external high-speed, automatic keyer.

4. Technical Characteristics

a. Radio Transmitter T-784/GRC-109.

Frequency range, 3 to 22 mc:
 Band 13.0 to 6.0 mc.
 Band 26.0 to 10.0 mc.
 Band 3 10.0 to 17.0 mc.
 Band 417.0 to 22.0 mc.
 Number of tubes2.
 Type of transmission Cw.
 Frequency controlCrystal.
 Distance rangeApproximately 75 miles¹ (121 kilometers).
 Power requirements450 volts dc at 100 ma, and 6.3 volts ac or dc at 1.2 amp.
 Power output10 to 15 w, depending on frequency.
 AntennaSingle, horizontal-wire, 25 to 75 feet long, depending on frequency.

¹Range will vary considerably according to frequency, terrain, and atmospheric conditions.

b. Radio Receiver R-1004/GRC-109.

Receiver typeSuperheterodyne.
 Number of tubes6.
 Frequency range, 3 to 24 mc:
 Band 13.0 to 6.0 mc.
 Band 26.0 to 12 mc.
 Band 312 to 24 mc.
 Types of signalsAm., cw, and mcw. received.
 Sensitivity5 uv for 10-db signal-to-noise ratio.
 Intermediate frequency 455 kc.
 If bandwidth 9 kc (6 db down).
 Fixed-frequency operation- Crystal used in local oscillator.
 Power input1.3 to 1.5 volts dc at 300 ma, and 90 to 108 volts dc at 20 ma.

Power output30 mw audio into a 4,000-ohm load.
 AntennaSame as transmitter, or a separate, single-wire².

²Separate transmitting and receiving antennas may improve operation, particularly at lower frequencies.

c. Power Supply PP-2684/GRC-109.

Alternate power inputs:
 Alternating current75 to 260 volts, 40 to 400 cycles.
 Battery, wet-cell of not less than 60 ampere-hour capacity.6 volts at 13 amp (key down); 6 volts at 5 amp (key up).
 Direct Current Generator G-43 G.450 volts dc at 115 ma; 6 volts dc at 2.5 amp.
 Power outputs:
 For Radio Transmitter T-784 GRC-109.450 volts dc at 100 ma; 6.3 volts ac or dc at 1.5 amp.
 For Radio Receiver R-1004 GRC-109.108 volts dc regulated at 20 ma; 1.5 volts dc regulated at 0.3 amp.
 For battery charging.6 volts dc at 3.8 amp.
 Number of tubes1 (voltage regulator).

d. Power Supply PP-26851/GRC-109.

Power inputs75 to 260 volts ac, 40 to 400 cycles.
 Power outputs:
 For Radio Transmitter T-784 GRC-109.450 volts dc at 100 ma; 6.3 volts ac at 1.5 amp.
 For Radio Receiver R-1004 GRC-109.108 volts dc regulated at 20 ma; 1.5 volts dc regulated at 0.3 amp.
 Number of tubes1 (voltage regulator).

5. Components of Radio Set AN/GRC-109

a. Components (fig. 2). The components of Radio Set AN/GRC-109 are listed in the following table:

| Quantity | Item | Height (in.) | Depth (in.) | Width (in.) | Unit Weight (lb) |
|----------|---------------------------------|-----------------|----------------|----------------|------------------------|
| 1 | Radio Transmitter T-784/GRC-109 | 8-5/8 | 5-1/2 | 5-7/16 | 9 |
| 1 | Radio Receiver R-1004/GRC-109 | 8-5/8 | 5-1/2 | 5-7/16 | 10 |
| 1 | Power Supply PP-2684/GRC-109 | 10 | 8-1/2 | 5-1/2 | 24.5 |
| 1 | Power Supply PP-2685/GRC-109 | 8-5/8 | 5-1/2 | 5-7/16 | 12 |
| 1 set | Operating accessories (b below) | | | | |
| 1 set | Running spares (c below) | | | | |

b. Items Comprising an Operable Radio Set FSN QTY *Nomenclature, part No., and mfr. code*
 AN/GRC-109 (FSN 5820-892-0681). Group I
 Radio Set AN/GRC-109

NOTE

The part number is followed by the applicable 5-digit Federal supply code for manufacturers (FSCM) identified in SB 708-42 and used to identify manufacturer, distributor, or Government agency, etc.

b. Items Comprising an Operable Radio Set AN/GRC-109 (FSN 5820-892-0881).

| FSN | Qty | Nomenclature part No., and mfr. code |
|----------------|--------|---|
| 5820-863-3498 | 1 | Antenna As-1722GRC-109: (Not installed) (Not mounted) |
| 5995-863-3499 | 1 | Cable Assembly, Power, Electrical CX-11042GRC-109: (Not installed) (Not mounted) |
| 5995-863-3497 | 1 | Cable Assembly, Special Purpose, Electrical CY-11041/GRC-109: (Not installed) (Not mounted) |
| 5965-223-4572 | 1 | Headset H465U: (Not installed) (Not mounted) |
| 5820-788-5496 | 1 | Maintenance Kit, Electronic Equipment MK33/GRC-109: (Not installed) (Not mounted) |
| 5820-823-2363 | 1 | Power Supply PP-2684/GRC-109: (Not installed) (Not mounted) |
| 5820-823-2364 | 1 | Power Supply PP-2685/GRC-109: (Not installed) (Not mounted) |
| 5820-892-0882 | 1 | Receiver, Radio R-1004/GRC-109: (Not installed) (Not mounted) |
| 6110-823-2365 | 1 | Regulator, Voltage CN690/GRC-109: (Not installed) (Not mounted) |
| 5820-892-4880 | 1 | Transmitter, Radio T-784/GRC-109: (Not installed) (Not mounted) |
| 6145-548-2742 | 125 ft | Wire: rubber covered; Belden Wire No. 8898 (1 ea coil 100 t, 1 ea coil 25 ft); (Not installed) (Not mounted) Group II |
| | | Maintenance Kit, Electronic Equipment MK-833/GRC-109 (Running Spare Items restored in this kit in addition to items listed below) |
| 6240-864-3330 | 1 | Adapter, Lampholder To Connector MX47912GRC-109 |
| 5995-985--8074 | 1 | Adapter, Headset Cable MX-6793/GRC, 109 |
| 5975-247-4855 | 1 | Clamp, Electrical: and clamp 58; 12701 |
| 5935-1991-1787 | 1 | Connector, Adapter; lampbase adapter; SM-B-4&3891; 80063 |

c. Operating Accessories (fig. 5). The following operating accessories are supplied with the radio set.

| FSN | Quantity | Item} |
|-------------------|----------|----------------------------------|
| 6110-823-2365 ... | 1 | Technical manuals |
| | 1 | Voltage Regulator CN-690/GRC-109 |

| | | |
|--------------------|--------|--|
| 5965-223-4572 | 1 | Headset H45/U |
| | 1 | Maintenance Kit (MK43S/GRC-109) |
| 6145-548-2742 ... | 100 ft | Wire, rubber-covered No. 18 |
| 5820-863-3498 ... | 1 | Antenna AS-172'2GRC-109 |
| 5995-863-3499 ... | 1 | Cable Assembly, Power, Electrical CX-11042/GRC109 |
| 6995-863-3497 ... | 1 | Cable Assembly, Special Purpose, Electrical CX-11041/GRC-109 |
| 6145-548-2742 ... | 25 ft | Wire, rubber-covered, No. 18 |
| | | Note. The 100-foot and 25-footlengths of No. 18rubbercovered wire is supplied as a single 125-foot length on contract DA-36-039-AMC04556(E) |

d. Maintenance Kit (fig. 4) The following items comprise Maintenance Kit, Electrical Equipment MK-833/GRC109.

| FSN | Quantify | Item |
|---------------------|----------|--|
| | 1 | Adapter MX-6792/GRC-109 (lampholder) |
| | 1 | Adapter, Headset Cable MX-6793/GRC-109 (headset) |
| | 1 | Case CY-4621/GRC-109 |
| | 1 | Clamp, Electrical (ground) |
| | 1 | Connector, adapter (amp base) |
| | 1 | Knife TL-29 |
| | 1 | Pliers, long-nosed |
| | 1 | Screwdriver |
| | 1 | Wrench, open end |
| | 1 | Wrench, Allen No. 8 |
| | 1 | set Running spares (as follows) |
| 5960-166-7648 | 2 | Electron tube, MIL type OB2 |
| 5960-262-0187 | 1 | Electron tube, MIL type 1L6 |
| 5960-188-3595 | 2 | Electron tube, MIL type IT4 |
| 5960-892-3460 | 1 | Electron tube MIL type 1U5WA |
| 5960-188-8569 | 1 | Electron tube, MIL type 2E26 |
| 5960-166-7666 | 1 | Electron tube, MIL type 6AC7 |
| 5960-280-4960 | 5 | Fuses, 2-amp, type 3AG |
| 5920-012-0151 | 3 | Fuses, 15-amp, type 3AG |
| 5970-356-0633 | 6 | Insulators, white porcelain |
| 6240-155-8706 | 1 | Lamp, incandescent, GE No. 47 |
| 6130-863-3576 | 1 | Vibrator, 6-volt |

6. Nomenclature and Common Names

| Nomenclature | Common name |
|--------------------------------|------------------------|
| Radio Set AN/GRC-109 | Radio set |
| Radio Transmitter | Transmitter |
| T-784iGRC-109. | |
| Radio Receiver | Receiver |
| R-1004/GRC-109 | |
| Power Supply | Large power supply |
| PP-2684/GRC-109. | |
| Power Supply | Small power supply |
| PP-2685/GRu-100. | |
| Voltage Regulator . | Voltage regulator |
| CN-690/GRC- 109. | |
| Direct Current Generator | Hand-cranked Generator |
| G-43/G. | |
| Headset H-65/U | Headset |

7. Description of Radio Set AN/GRC-109

a. The radio set includes a transmitter, a receiver, two power supplies, and a simple antenna system. Figure 2 shows the major components of the radio set, which is portable and requires no mounts. With the exception of the antenna system, the radio set may be assembled without the use of tools. The major components are sealed for operation in extreme environmental conditions and protected against excessive moisture by renewable desiccates.

b. The transmitter and receiver may be operated from either of the two power supplies or from the hand-cranked generator with the addition of the voltage regulator. Permanently attached power cables on the transmitter and receiver plug into the designated connectors on the power supplies or the voltage regulator. The large and small power supplies can operate on a variety of alternating-current (ac) voltages and frequencies. The large power supply can also be operated from a 6-volt storage battery or the hand-cranked generator. The large power supply also supplies 6 volts for recharging the storage battery. Cables and adapters necessary for connecting the power supplies to various power sources are supplied as

part of the operating accessories. Figure 5 shows all possible power options for operating the radio : 1 set.

c. A common antenna may be used for both the transmitter and receiver, or a separate antenna may be used for each of the two components. Break-in operation is possible when a common antenna is being used. Slightly better performance may be obtained on lower frequencies by the use of separate antennas. Antenna connections are made to binding posts on the front panel of the transmitter and receiver.

8. Description of Major Components

a. *Radio Transmitter T-7841GRC-109.* (fig. 2). The transmitter is a miniature, crystal controlled cw transmitter that covers 3 to 22 megacycles (mc) in four bands. The power output is 10 to 15 watts, depending on the operating frequency. The transmitter is tuned by three front-panel controls with the aid of a tuning chart and tuning lamps. Any single wire system with an impedance of 72 to 1,200 ohms may be used as an antenna. A front-panel telegraph key is used for manual operation. There is also provision for attaching an external key or an automatic high-speed keyer. The transmitter is housed in a sealed, waterproof case.

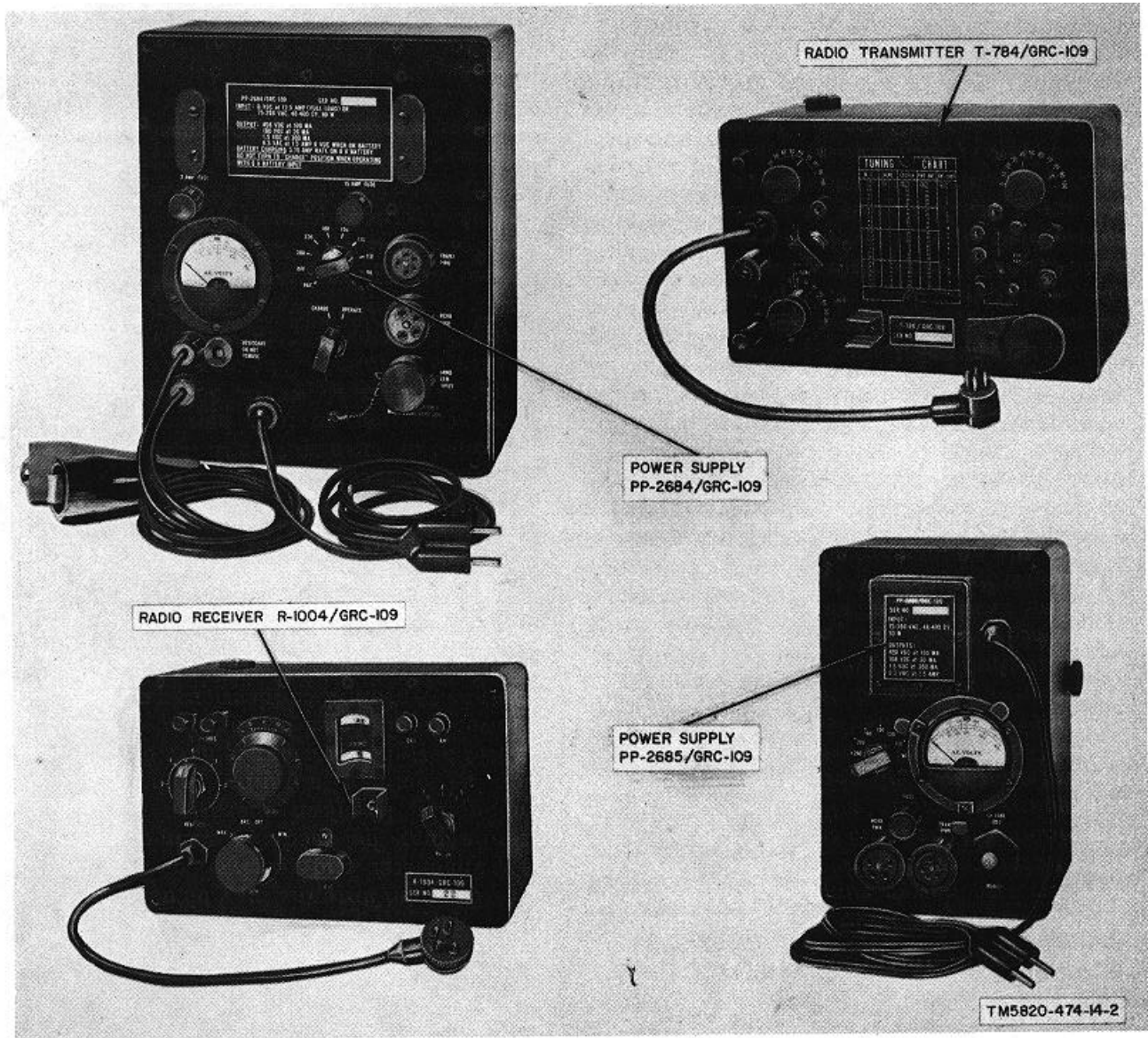
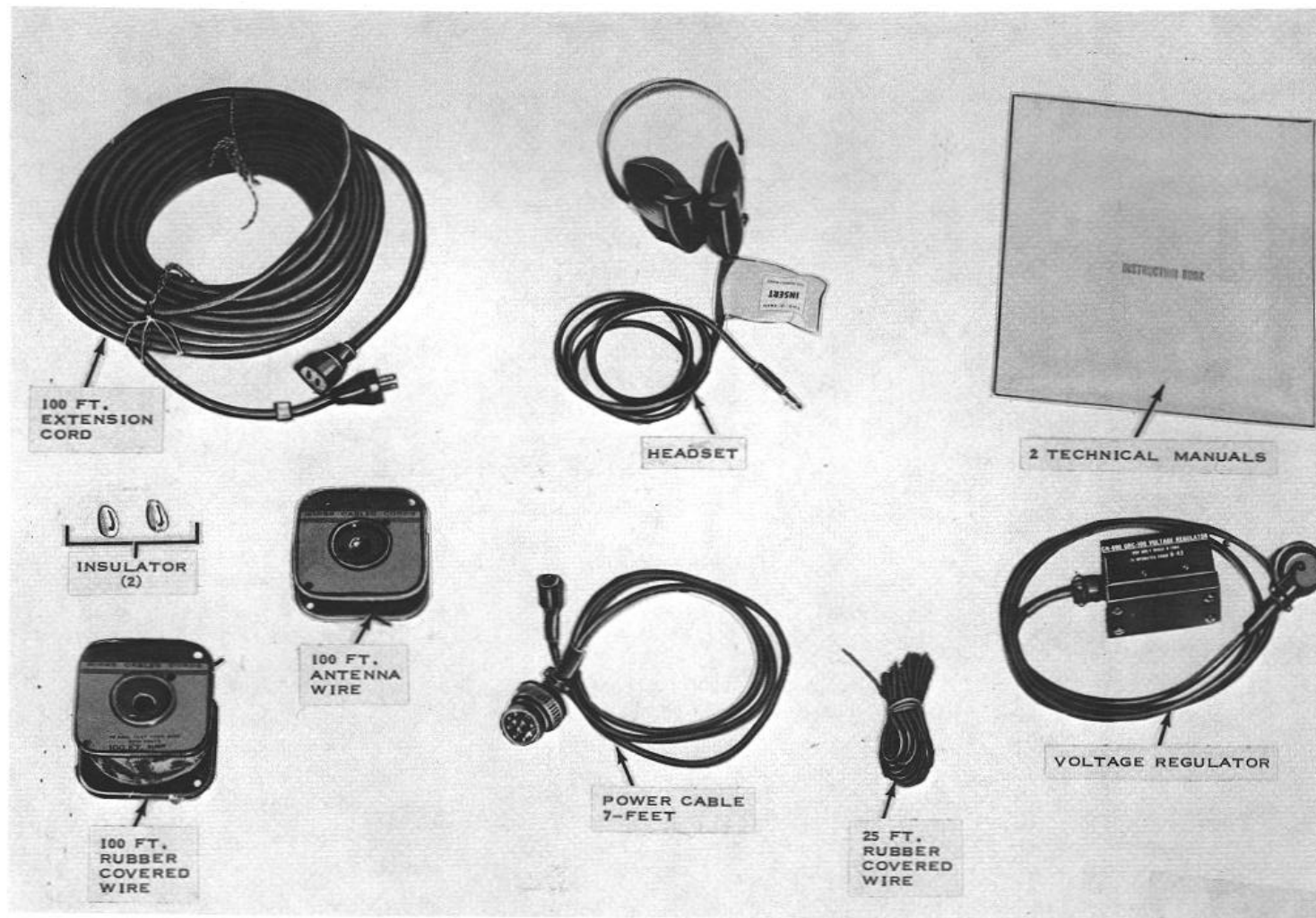

Figure 2. Major components.



TM 5820-474-14-C4-1

Figure 3. Operating accessories.

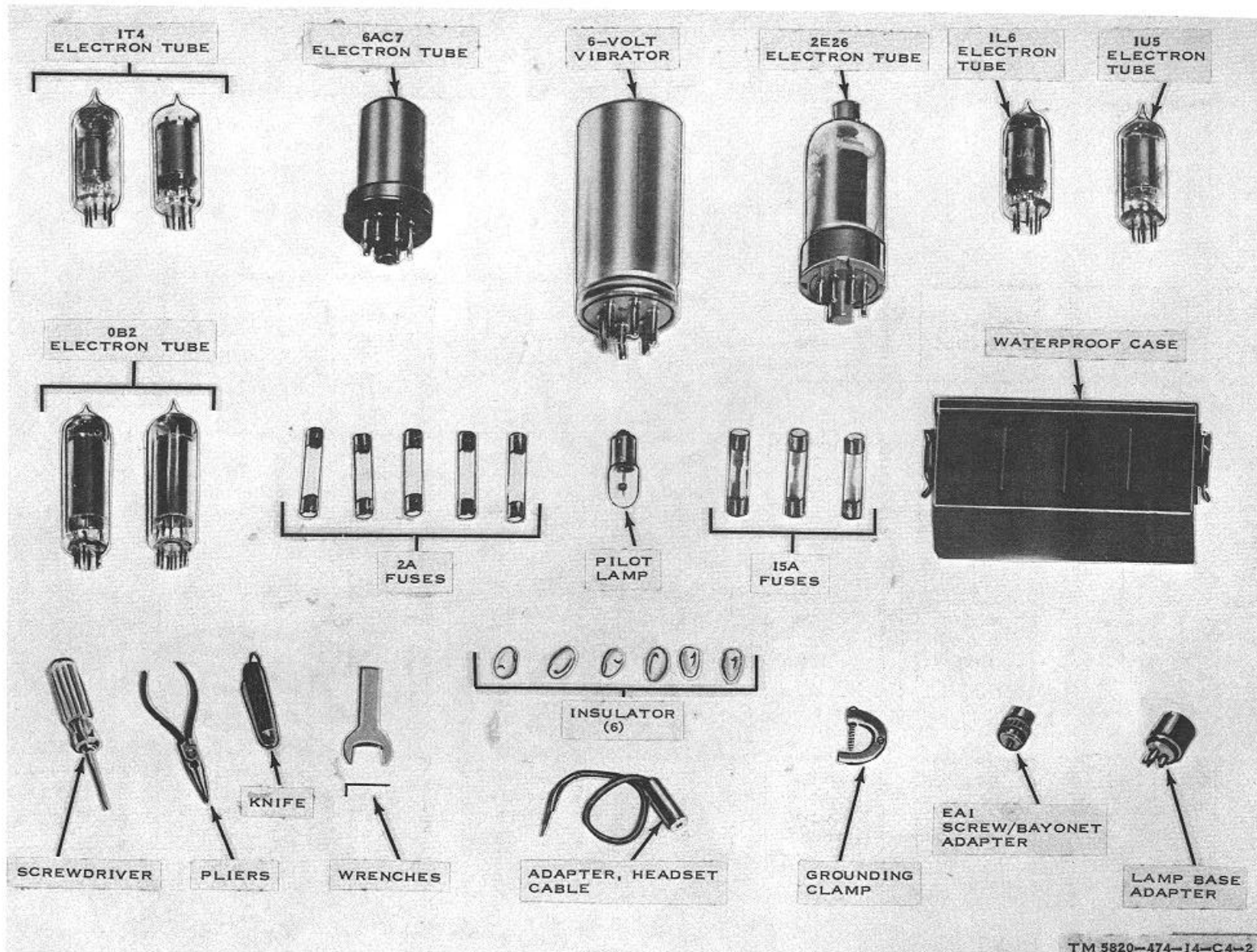
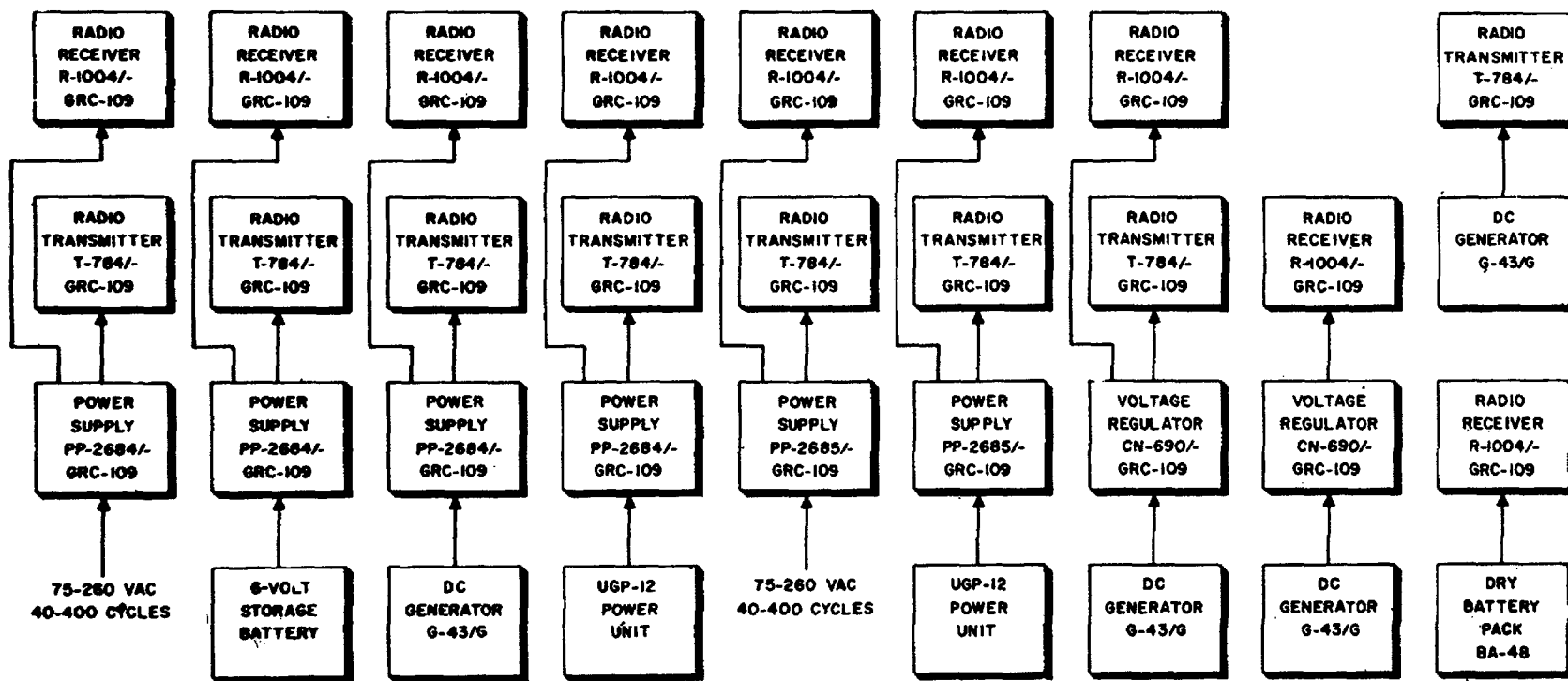

Figure 4. Maintenance Kit, Electrical equipment MK-8333/GRC-109.



TM 5820-474-14-3

Figure 5. Primary power options.

b. *Radio Receiver R-1004/GRC-109* (fig. 2).

The receiver is a miniature, Superheterodyne communications receiver that can receive am., cw, and modulated continuous wave (mew) signals from 3 to 24 me. The range is covered in three bands. Provision is made for fixed-frequency operation by a front-panel plug-in crystal. A frequency dial and a vernier scale permit accurate tuning. Headphone, ground, and antenna connections are made to the front-panel binding posts. The receiver is housed in a sealed, waterproof case.

c. *Power Supply PP-2684/GRC-109*. The large power supply (fig. 2) furnishes B + and filament voltages for the transmitter and receiver. The voltages supplied to the receiver are regulated. This power supply may be operated from either of three power sources: ac, from 75 to 260 volts, 40 to 400 cycles; a 6-volt storage battery; a hand-cranked generator. In addition, when operated from ac lines, the large power supply may be used to recharge a 6-volt storage battery. A meter on the front panel indicates the voltage of the ac source to which the power supply is connected. The large power supply is housed in a sealed, waterproof case.

d. *Power Supply PP-2685/GRC-109*. The small power supply (fig. 2) furnishes B + and filament voltages to the receiver and transmitter. The voltages supplied to the receiver are regulated. The small power supply operates only from ac sources which supply 75 to 260 volts, 40 to 400 cycles. A meter on the front panel indicates the voltage of the ac source to which the power supply is connected. The small power supply is housed in a sealed, waterproof case.

9. Description of Minor Components

The minor components of Radio Set AN/ GRC-109 are shown in figure 3.

a. *Voltage Regulator CN-690/GRC-109*. The voltage regulator is used when the transmitter and

receiver are directly powered by the hand-cranked generator. The power cables from the transmitter and receiver will plug directly into the appropriate jacks on the voltage regulator. The voltage regulator regulates B+ and filament voltages for the receiver.

b. *7-Foot Power Cable*. This cable is used to connect the hand-cranked generator to the large power supply.

c. *100-Foot Extension Cord*. The extension cord is used to connect the large or small power supplies to the UGP-12 gasoline-engine generator when the generator is used.

d. *AN/GRC-109 Antenna System*. The antenna system used with the radio set is a simple inverted L. It is constructed of 100 feet of bare copper wire and two porcelain insulators.

e. *Headset H-65U*. The headset is used with Radio Receiver R-1004/GRC109 and terminates the audio output of the receiver.

It is connected to the PHONES binding posts on the front panel of the receiver through Adapter, Headset Cable MX6793/GRC-109.

10. Additional Equipment Required

The following equipment is not supplied as part of the radio set but may be used with it under certain conditions:

a. *Vehicular Storage Battery*. A 6-volt storage battery instead of an ac source or hand cranked generator may be used with the large power supply to power the radio set.

b. *Direct Current Generator G-43/G*. The hand-cranked generator may be used with the large power supply or with the voltage regulator to power the radio set.

CHAPTER 2
INSTALLATION

11. Unpacking
(fig. 6)

a. *Packing Data.* When packed for shipment, each of the four major components of the radio set is sealed in two corrugated cardboard cartons consisting of an inner carton with cardboard fillers, and an outer carton.

For certain types of shipments, the four doubly boxed units are packed in a sealed, wooden packing case bound with metal straps; the spare parts and accessories are packed in a separate wooden packing case.

| Carton No. | Height (in.) | Width (in.) | Depth.(in.) | Volume (cu ft) | Unit Weight (lb) | Contents of box |
|------------|--------------|-------------|-------------|----------------|------------------|--------------------|
| 1 of 5 | 9-1/4 | 6-1/4 | 6 | 0.2 | 11 | Transmitter |
| 2 of 5 | 9-1/4 | 6-1/4 | 6 | 0.2 | 12 | Receiver |
| 3 of 5 | 10-3/4 | 9-1/4 | 6-1/4 | 0.36 | 27 | Large power supply |
| 4 of 5 | 9-1/4 | 6-1/4 | 6 | 0.2 | 14 | Small power supply |
| 5 of 5 | 12-1/4 | 3-7/8 | 6-1/4 | 0.17 | 17 | Spare parts box |

Total weight 81 pounds

b. *Removing Contents.* Perform all the procedures outlined below when unpacking the equipment from the wooden packing cases. When unpacking the equipment in cartons, omit the procedures given in (1) through (4) below.

- (1) Position the wooden packing case on a flat surface with the top of the case uppermost as indicated by the lettering on the box.
- (2) Cut the metal straps that bind the wooden packing case; use shearing snips or the shearing jaws of ordinary pliers.
- (3) Pull out the nails along the four edges of the top cover with a nail-puller and remove the cover. Do not attempt to pry off the cover because the equipment may become damaged..
- (4) Remove the outer cartons from the wooden packing cases. Open any torn carton immediately ((5) below) to determine whether the equipment is damaged.
- (5) Open the cartons by tearing away the taped flaps and withdrawing the inner packing box. Open the inner carton and remove the contents. Do not force sharp or pointed objects into the cartons.

a. *Damage.* Inspect the components for external damage. Loosen the four captive locking screws on each corner of the front panels of the major components. The airtight covers may have to be pried off, particularly if they have been kept in extended storage. Take care not to damage the sealing gasket under the cover. Inspect the control panels for damage to the knobs, lamps, dials, and meter faces. Refer to paragraph 2 if any damage is noted.

b. *Equipment Inventory.* After the cartons are opened, check for completeness against the tables of components (para 5).

13. Siting

a. *Power Source.* The availability and suitability of a power source are important in the choice of an operating site. If ac line power is to be used, make certain that it is alternating current between 75 and 260 volts, and that the frequency is between 40 and 400 cycles.

Caution: Operation from 25-cycle or direct-current-lines will damage the equipment. The characteristics of the ac source can often be determined by an examination of the electrical appliances that are powered by the intended ac source. Normally,

12. Checking Unpacked Equipment

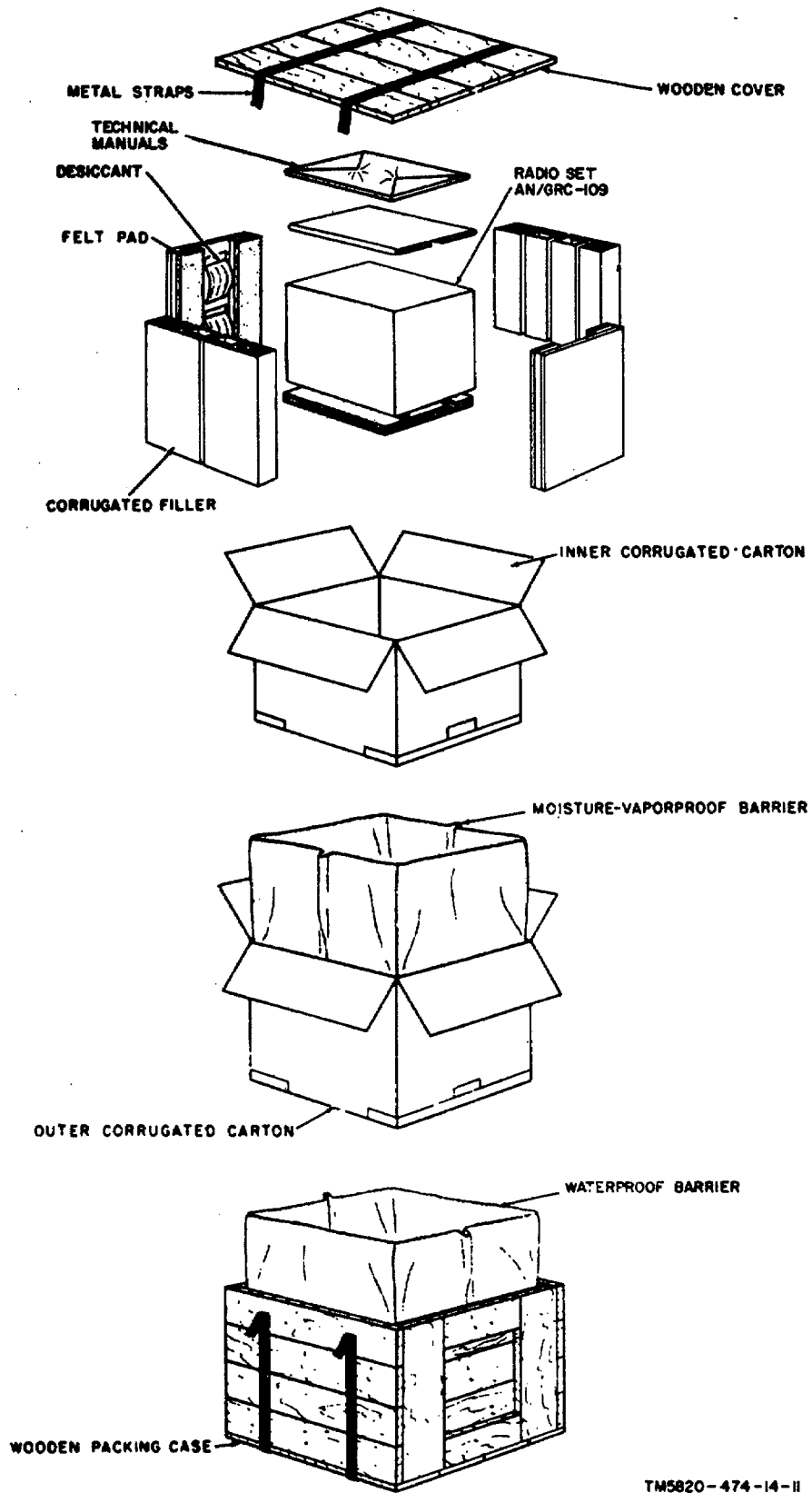

TM5820-474-14-II

Figure 6. Typical packaging.

electrical appliances carry a manufacturer's rating on a label, which specifies the operating voltage and frequency. If possible, verify the characteristics of the ac power by making inquiries of local personnel.

b. Antenna Location. When locating the antenna, consider the following:

- (1) Radio signals are absorbed and sometimes reflected by adjacent obstructions, such as hills, metal buildings, and bridges; or by telephone lines that extend above the height of the antenna. Transmitted and received signals have a greater range when the antenna is as high above level ground or bodies of water as possible.
- (2) If transmission and reception in all directions are desired, locate the antenna on the highest hill in the area.
- (3) When operating in rear areas, keep the equipment as far as possible from sources of interference, such as power or telephone lines, radar equipment, and field hospitals.
- (4) Jamming action against the receiver is always a possibility. The effects of jamming may be reduced by locating the antenna so that nearby obstructions act as a screen in the direction of probable sites of jamming transmitters. This screening action may also reduce the transmitted signal strength in the direction of the jamming transmitter, thereby making interception of signals more difficult.

14. Installation of Radio Set AN/GRC-109

a. Positioning of Equipment at Operating Site. The positioning of equipment at the operating site depends upon three major considerations: available power, antenna location, and equipment location.

- (1) *Available power source.* If no ac power is available, operation from a storage battery or hand-cranked generator is necessary. If the correct ac power is

available, either of the two power supplies may be used.

- (2) *Antenna location.* Antenna location is often a primary determining factor when positioning the equipment at the operating site. Therefore, before the antenna is erected, determine which end of it is to be connected to the radio set.
- (3) *Equipment location.* Position the receiver, the transmitter, and the power supply on a flat, stable, and dry surface, preferably a table, box, or shelf of convenient height that permits operation over long periods of time without operator fatigue.

b. Erection of Antenna. To provide reliable communication over maximum distances, an efficient and correctly installed antenna is essential. The antenna system supplied consists of a 100-foot coil of bare antenna wire, two coils of rubber covered wire (100 feet and 25 feet in length), insulators, and a ground clamp. To erect the antenna, proceed as follows:

- (1) Install a long-wire, inverted antenna (fig. 7); use the 100-foot length of antenna wire and the insulators. If possible, make the horizontal portion of the antenna 60 to 70 feet long, and the vertical portion 30 to 40 feet long. If the suggested horizontal and vertical dimensions cannot be followed, use any combination of horizontal and vertical lengths with the total length at least 100 feet, and the horizontal portions as high as possible.
- (2) If the antenna length cannot be made to total 100 feet, operation is possible with shorter lengths, depending on the operating frequency. Use the following chart to determine the minimum antenna lengths for various operating frequencies.

| Frequency (mc) | Total minimum length (ft) |
|----------------|---------------------------|
| 3 to 5 | 75 |
| 5 to 7 | 50 |
| 7 to 9 | 35 |
| 9 to 22 | 25 |

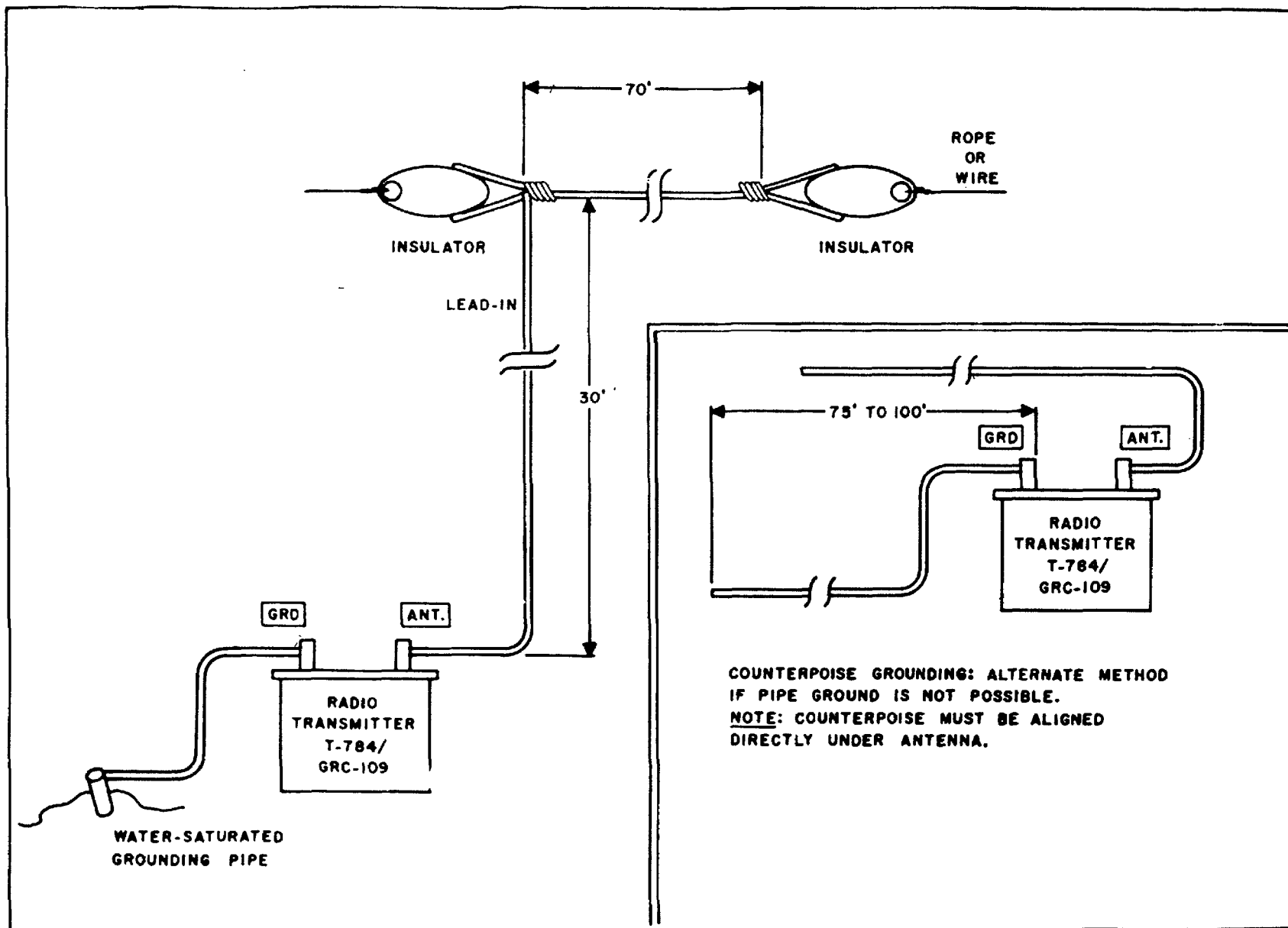

TM 5820-474-14-10

Figure 7. Antenna system.

- (3) If difficulty is experienced in loading a particular antenna, lengthen or shorten the antenna about 10 percent.

c. *Ground System* (fig. 7). The efficiency of the antenna system is largely determined by the quality of the ground system. A good ground is essential when a storage battery or hand-cranked generator is used to power the radio set, and highly desirable when operating from an ac power source. Described below are two ground systems: pipe grounding, and counterpoise grounding.

- (1) *Pipe grounding.* Use this method of grounding if possible. The wire between the GND post on the transmitter and the connection to ground (soil) must be as short as possible. To obtain a good ground, connect the ground wire to a cold-water pipe with the ground clamp. If no cold-water pipe is available, drive a pipe 4 to 6 feet into the soil, and then connect the ground clamp and ground wire to the pipe. Keep soil about the pipe saturated with water.
- (2) *Counterpoise grounding.* If conditions at the operating site prohibit pipe grounding, a counterpoise must be installed. A counterpoise consists of one or more extended lengths of wire, 75 to 100 feet in length, connected to the GND binding post on the transmitter and placed on the surface of the ground directly beneath the horizontal portion of the antenna.

d. *Preliminary Connections, Common Antenna System* (fig. 8 and 9).

- (1) Connect the H-65/U to the PHONES binding posts (fig. 9) on the receiver.
- (2) Connect the antenna lead-in to the ANT binding post (fig. 8) on the transmitter.
- (3) Connect a length of rubber-covered wire between the ANT bindingpost on the receiver (fig. 9) and the RCVR ANT binding post (fig. 8) on the transmitter. Keep this connection as short as possible.
- (4) Connect a wire between the GRD binding post on the receiver and the RCVR GND. binding post on the transmitter. Keep this connection as short as possible.

- (5) Connect the ground system to the GND binding post on the transmitter.

e. *Preliminary Connections, Separate Transmitting and Receiving Antennas* (fig.8 and 9). Separate transmitting and receiving antennas may prove to be more effective under poor transmission conditions, particularly at lower frequencies.. Separate transmitting and receiving antennas are recommended when using an external high-speed keyer.

- (1) Connect the headset to the PHONES binding posts (fig. 9) on the receiver.
- (2) Connect one lead-in to the ANT binding post (fig. 8) on the transmitter.
- (3) Connect the other antenna lead-in to the ANT binding post (fig. 9) on the receiver.
- (4) Connect the RCVR GND binding post (fig. 8) on the transmitter to the GND binding post on the receiver with a short wire.
- (5) Connect the ground system to the GND binding post on the transmitter.
- (6) Connect the REC ANT bindingpost and the REC GND binding post on the transmitter with a short wire.

15. Unit Interconnections, Primary Power Options

This paragraph contains instructions for connecting the transmitter and the receiver to the optional power sources.

Caution

Do not make connections to primary power sources until all units are interconnected.

Note

When not using the hand-cranked generator, be sure that the cover is in place on the HAND GEN INPUT receptacle on the large power supply (fig. 10).

a. Ac Line Operation.

- (1) Plug the transmitter interconnecting cable into the TRANS. PWR. receptacle on the large or small power supply (fig. 10 and 11).

- (2) Plug the receiver interconnecting cable into the RCVR PWR. receptacle on the large or small power supply.
- (3) Turn the power selector switch on the power supply to OFF.
- (4) Connect the power supply power cord to the ac source.

b. 6-Volt Storage Battery Operation.

- (1) Plug the transmitter interconnecting cable into the TRANS. PWR. receptacle on the large power supply (fig. 10).
- (2) Plug the receiver interconnecting cable into the RCVR PWR. receptacle on the large power supply.
- (4) Turn the CHARGE-OPERATE switch to OPERATE.
- (5) Connect the red battery lead to the positive terminal of the battery.
- (6) Connect the black battery lead to the negative terminal of the battery.

c. Hand-Cranked Generator Operation with Large Power Supply.

- (1) Connect the transmitter interconnecting cable to the TRANS. PWR. receptacle on the large power supply (fig. 10).
- (2) Connect the receiver interconnecting cable to the RCVR PWR. receptacle on the large power supply.
- (3) Connect the hand-cranked generator to the HAND GEN. INPUT receptacle on the power supply with the 7-foot power cable.
- (4) Turn the power selector switch to OFF.

d. Hand-Cranked Generator Operation with Voltage Regulator.

- (1) Connect the transmitter interconnecting cable to the proper receptacle on the voltage regulator.
- (2) Connect the receiver interconnecting cable to the proper receptacle on the voltage regulator,
- (3) Connect the interconnecting cable on the voltage regulator to the receptacle on the hand-cranked generator.

CHAPTER 3

OPERATING INSTRUCTIONS

Section I. OPERATING CONTROLS AND INDICATORS

16. Damage from Improper Settings
(fig. 10 and 11)

Take the following precautions when setting the power supply controls:

a. Before connecting either power supply to the ac source, be sure that the power selector switch is in the OFF position.

b. If the A.C. VOLTS meter indicates a voltage value that is between markings on the power selector switch, always use the higher numbered switch setting. Example: If the A.C. VOLTS meter reads 120 volts, turn the power selector switch to the 130 position. Never advance the power selector switch to a setting lower in numerical value than the A.C. VOLTS meter indication. If the switch is set to a value lower than the voltmeter indication, the 2-ampere fuse will blow.

c. Do not turn the CHARGE-OPERATE switch on the large power supply to the CHARGE position when operating from a 6-volt storage battery. To charge a battery, the power must be available from the ac source. The transmitter and receiver cannot be operated with the large power supply during charging. For charging, turn the power selector switch to the proper position as indicated on the A.C. VOLTS meter, connect the battery

leads to the proper terminals on the battery, and turn the CHARGE-OPERATE switch to the CHARGE position.

17. Controls and Indicators

a. Radio Transmitter T-784/GRC-109 (fig. 8).

Note: Numbers in parenthesis below are circled on the panel.

| Control or indicator | Function |
|-------------------------------------|--------------------------------------|
| Band switch (1) | Selects frequency band |
| Exciter tuning control (2) | Tunes exciter plate circuit |
| Power amplifier tuning control (3)- | Tunes power amplifier |
| TUNE control (4) | Tunes antenna circuit |
| Power amplifier lamp | Indicates tuning of power amplifier. |
| Exciter lamp | Indicates tuning of exciter stage. |
| Antenna lamp | Indicates tuning of antenna |
| Telegraph key | Keys transmitter for cw operation. |

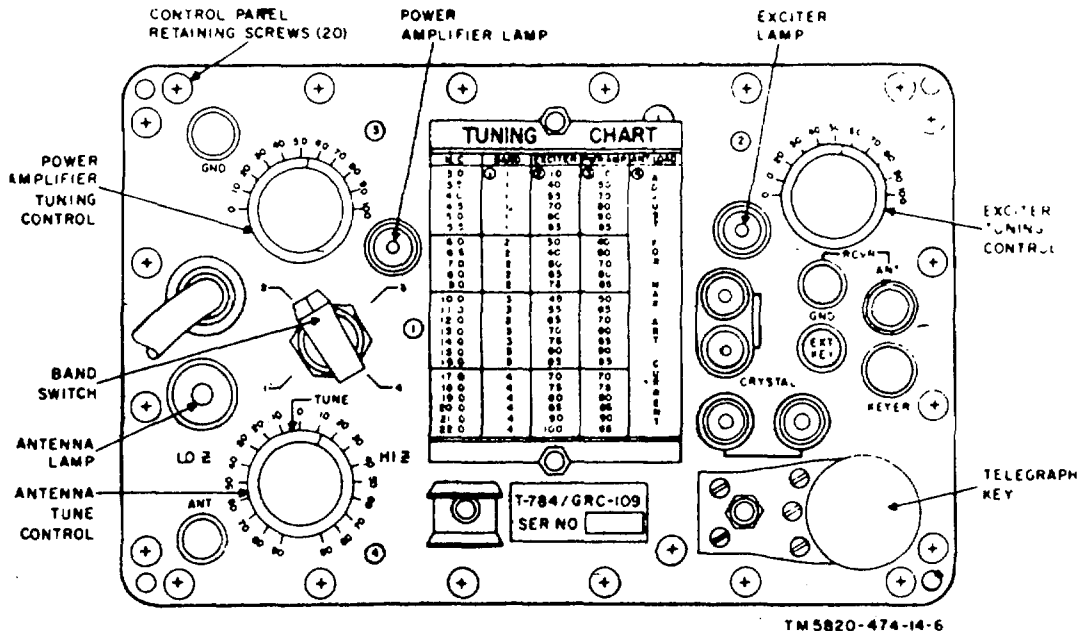

Figure 8. Radio transmitter, t-184/GRC-109, front panel.

b. Radio Receiver R-1004/GRC-109 (fig. 9).

| Control or indicator | Function |
|------------------------|---|
| TUNING control | Tunes receiver |
| RANGE switch | Selects frequency band |
| BEAT OSC control | Varies pitch of received signal. for cw reception |
| GAIN-BAT OFF control . | Adjusts audio level in headset, turns receiver on and off |
| Frequency dial | Indicates received signal frequency |

| Control or indicator | Function |
|------------------------|--|
| A. C. VOLTS meter | battery or had-cranked generator operation; turns power supply off. Indicates ac source voltage. |
| CHARGE-OPERATE switch. | Permits battery operation of set in OPERATE position; charge battery in CHARGE position when power supply is connected to ac source. |

c. Power Supply PP-2685/GRC-109 (fig. 10).

| Control or indicator | Function |
|----------------------------|--|
| Power selector switch..... | Connects circuit for ac source voltage available; connects circuit for |

d. Power Supply PP-2685/GRC-109 (fig. 11).

| Control or indicator | Function |
|-----------------------|---|
| Power selector switch | Connects circuit for ac source voltage available; turns power supply off. |
| A. C. VOLTS meter | Indicates ac source voltage. |

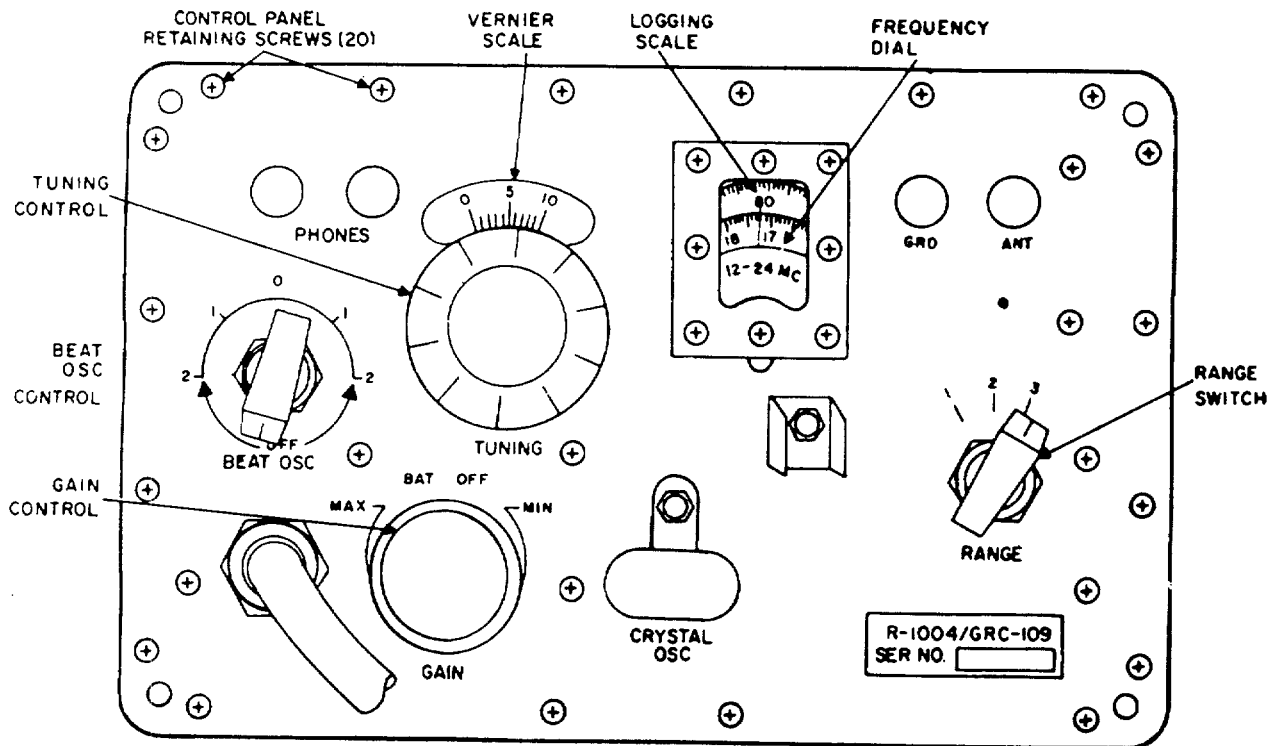

Figure 9. Radio Receiver R-100/GRC-109, front panel

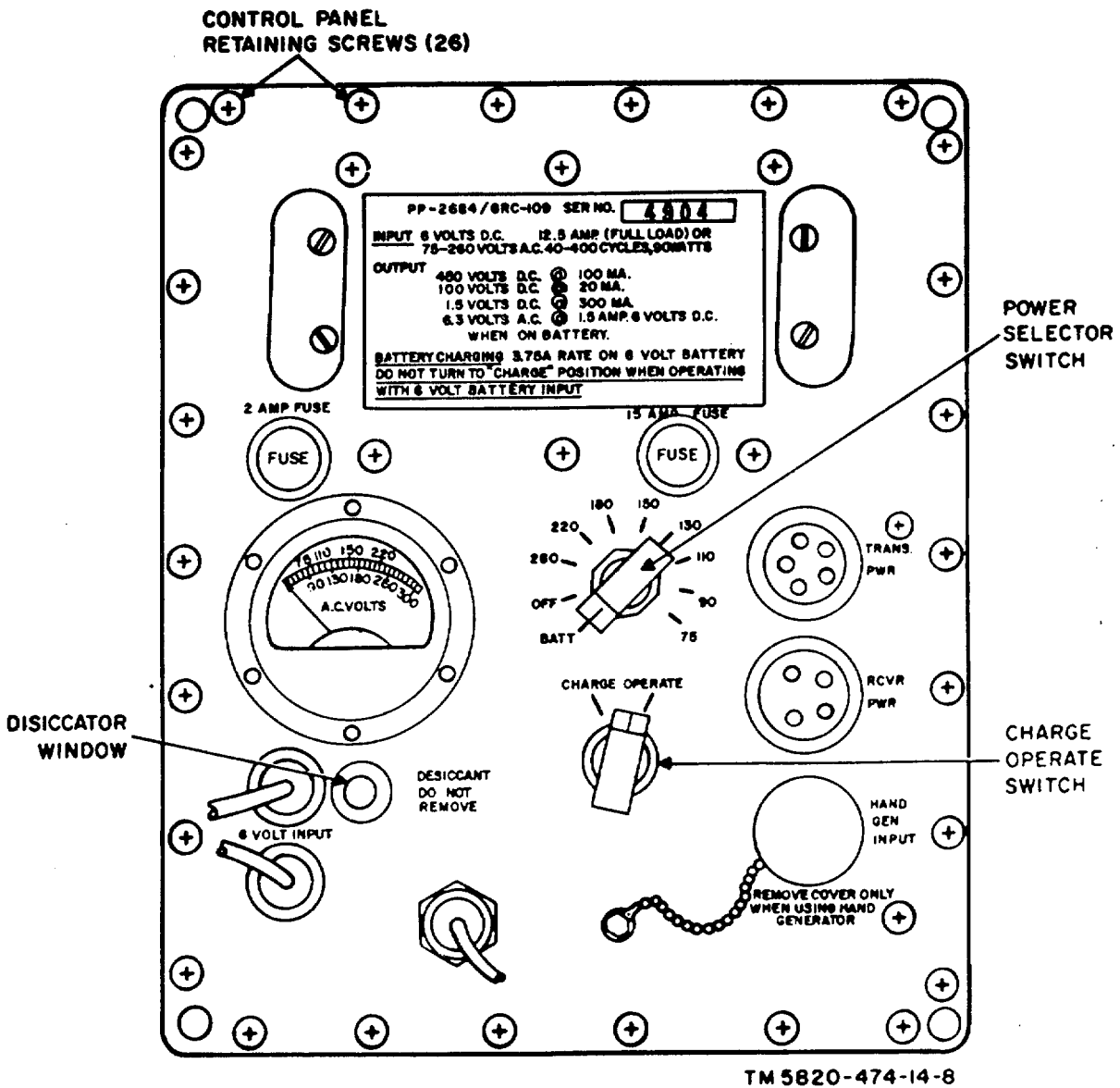

Figure 10. Power Supply PP-2684/GRC-109, front panel.

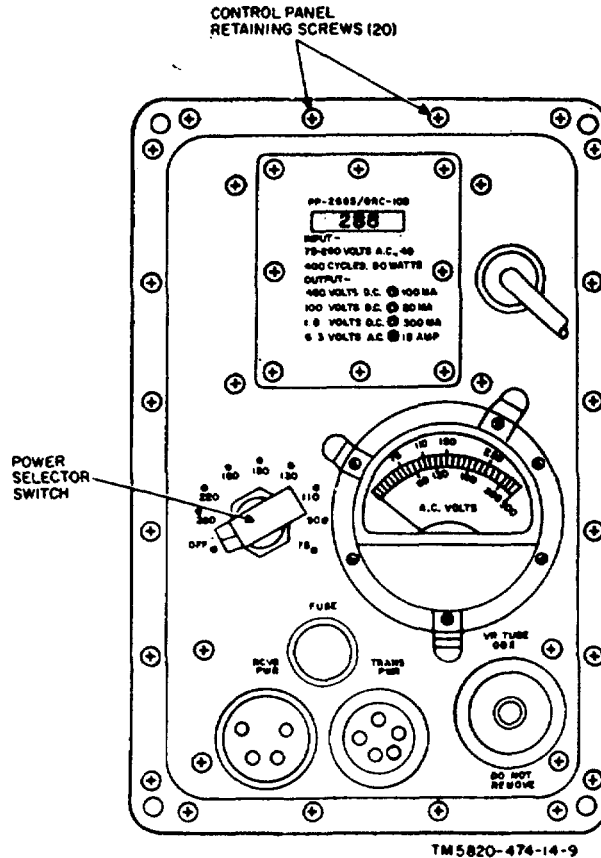

Figure 11. Power Supply PP-f686/GRC-109, front panel,
Section II. OPERATION UNDER USUAL CONDITIONS

18. Preliminary Starting Procedure

Refer to the installation procedures (para 14) before operating; operating procedures differ with various power sources.

a. Plug in the proper transmitting crystal for the desired operating frequency.

The crystal frequency may be the operating frequency, or it may be one-half or one-third the operating frequency. Crystals equal to one-fourth the operating frequency may also be used, but the transmitter output power will be reduced.

b. Consult the tuning chart on the transmitter (fig. 8) and turn controls (1), (2), and (3) to the settings indicated on the chart.

c. Set the RANGE switch on the receiver (fig. 9) to the band that includes the frequency of the signal to be received.

d. Adjust the receiver TUNING control until the operating frequency appears under the hairline on the frequency dial.

e. If the receiver is to be operated with crystal control, plug in the crystal that will produce the desired operating frequency. The proper receiving crystal is determined by adding or subtracting 455 kilocycles (kc) from the operating frequency to obtain the control frequency. The crystal can then be selected for one-half or one-third the control frequency. For convenience in operation, mark the receiving crystals receiver and stamp them with the receiving frequency.

19. Starting Procedure, Power Supplies

With the controls set as given in the preliminary starting procedure, perform the steps described below.

Note

If an abnormal indication is obtained during the starting or tuning procedure, refer to the operational checklist (para 33) for the corrective measures.

a. For operation from an ac source,; observe the indication on the A.C. VOLTS meter, and then advance the power selector switch on the power supply (fig. 10 or 11) to the setting that corresponds to the voltmeter indication. If the voltmeter indicates a value between switch settings, set the switch at the higher numerical switch position.

b. For operation from a 6-volt storage battery, turn the CHARGE-OPERATE switch on the large power supply to the OPERATE position. Turn the power selector switch to the BAT. position.

c. For hand-cranked generator operation with the large power supply, leave the power selector switch in the OFF position.

d. Allow several minutes for the equipment to warm up.

20. Starting and Tuning Procedure, Radio Transmitter T-784/GRC-109

(fig. 8)

a. Depress the telegraph key.

b. Adjust control (2) for maximum brightness on the exciter lamp. If maximum brightness is obtained at more than one setting of the control, turn the control to the nearest figure indicated on the tuning chart.

c. Adjust control (3) for maximum brightness on the power amplifier lamp. If maximum brightness is obtained at more than one location of the control, adjust the control to the nearest figure indicated in the tuning chart.

d. Adjust control (4) slowly, first to the left then to the right; at the same time, readjust control (3) to obtain maximum brightness of the antenna lamp. Maximum brightness of the antenna lamp is subject to wide variation, depending on the antenna length and the operating frequency. If the 1/2 illumination of the antenna lamp is perceptible, make the initial antenna adjustment by turning control (4) for maximum brightness of the power amplifier lamp. Adjust 1/2 control (3) to give maximum brightness of the power

amplifier lamp each time. control (4) is adjusted. Continue this procedure, alternately adjusting controls (3) and (4) for maximum brightness of the power amplifier lamp, until a perceptable glow observed in the antenna lamp; then adjust controls (3) and (4) for maximum brightness of the antenna lamp.

e. When further adjustment of controls (3) and (4) does not yield an increase in antenna lamp brightness, adjust control (2) very slightly for maximum brightness of the antenna lamp. This final adjustment of control (2) is very important, especially if the crystal being used is one-fourth the operating frequency.

f. Release the telegraph key; the transmitter is now tuned.

21. Starting -and Tuning Procedure, Radio Receiver R-1004/GRC-109

(fig. 9)

a. Advance the GAIN control clockwise until a rushing (hissing) sound is heard in the headphones.

b. If both the receiver and the transmitter are operated on the same frequency, use the transmitter signal to tune the receiver. Under these conditions, depress the telegraph key on the transmitter and slowly rock the receiver tuning dial above and below the approximate frequency setting until a squeal is heard. Release the telegraph key; the squeal should stop at the same instant. If the squeal does not stop when the telegraph key is released, the receiver is not tuned to the transmitter frequency. Depress the telegraph key and continue to slowly turn the tuning dial; check each time a squeal is heard by releasing the telegraph key until the receiver is tuned to the transmitter frequency.

22. Operating Procedures

For operating convenience, a logging scale and a vernier scale (fig. 9) are provided on the receiver. These scales can be used to accurately record the frequency of a received signal for future reference.

.Note that 10 units on the vernier scale correspond to one unit on the logging scale.

a. *Continuous-Wave Reception.* Start

the equipment as instructed in paragraphs 18, 19, and 21.

- (1) Rotate the TUNING dial to tune in the signal.
- (2) Adjust the GAIN control for the desired sound level in the headset.
- (3) Adjust the BEAT OSC control until the received signal has the desired pitch.

b. Amplitude-Modulated (AM.) Reception. Start the equipment as instructed in paragraphs 18, 19, and 21.

- (1) Turn the BEAT OSC control to OFF.
- (2) Rotate the TUNING control to tune in the signal.
- (3) Adjust the GAIN control for the desired sound level in the headset.

c. Transmission. Start the equipment as instructed in paragraphs 18, 19, and 20.

- (1) Telegraph key. After the transmitter has been tuned (para 20), transmit by operating the telegraph key.
- (2) External telegraph key. If operation is desired with an external telegraph key, connect the leads from the external key to the binding posts marked EXT. KEY and GND.

Note

The front-panel key and the external key are now connected in parallel; the front-panel key is still operative.

- (3) High-speed keyer. To operate with a high-speed keyer, remove the dummy plug from the connector marked KEYS, and plug the highspeed keyer into the connector.

23. Operating Precaution

Overheating may occur if the radio set is operated in inclosed space without adequate ventilation. Always try to provide ventilation when operating the equipment.

24. Recognition and Identification of Jamming

The receiver may be jammed purposely or accidentally by other stations in the area. Jamming is accomplished by the transmission of a strong signal on the same frequency, which makes it difficult or impossible to hear the desired signal. Unusual noises or strong interference heard on the receiver may be caused by intentional jamming, noise from a local source, or a defective receiver. To determine whether the interference is originating in the receiver, disconnect the antenna and short the ANT post to the chassis. If the interference continues, the receiver is defective. Jamming signals may be classified as cw or modulated. A jamming signal may be intended to block a single frequency; this method is called spot jamming. One or more transmitters may be used to jam a band of frequencies; this method is called barrage jamming.

25. Antijamming

When it is known that a receiver is being jammed, the operator will notify his superior officer immediately and continue to operate the equipment. To provide maximum intelligibility of jammed signals, follow the operational procedure: below:

a. Adjust and operate the receiver as outlined in paragraphs 21 and 22.

b. Vary the TUNING dial several vernier units on each side of the desired signal.

This may cause some separation of the desired signal and the jamming signal.

c. Vary the GAIN control setting. This may reduce the jamming signal enough to permit the weaker desired signal to be heard.

d. If the above procedures do not provide sufficient signal separation for operation, change to an alternate frequency and alternate call sign.

26. Stopping Procedure

a. When operating with the large or small power supply, shut down the entire radio set by turning the power supply power selector switch (figs. 10 and 11) to the OFF position.

b. To remove the power from the receiver only, rotate the receiver GAIN control (fig. 9) counterclockwise to the BAT. OFF position.

Section III. OPERATION UNDER UNUSUAL CONDITIONS

27. Operation at Low Temperatures

a. Do not operate the radio at temperatures below -15°C ($+5^{\circ}\text{F}$). At temperatures lower than -15°C , operate the radio in a heated shelter where the temperature is maintained within the operating limits of the set.

b. Protect the equipment from freezing rain, sleet, and snow during both operation and storage.

28. Operating Under Tropical Conditions

The radio set may be operated in tropical, swampy areas where extreme moisture conditions exist. Try to keep the equipment dry, and use silica gel or another desiccant to help keep the equipment dry when it is stored.

29. Operation in Desert Climate

Do not operate the radio set at temperatures higher than $+55^{\circ}\text{C}$ ($+131^{\circ}\text{F}$). In temperatures higher than $+55^{\circ}\text{C}$, the equipment must be operated in a cool shelter.

CHAPTER 4

OPERATOR'S MAINTENANCE

30. Scope of Operator's Maintenance

The maintenance duties assigned to the operator of Radio Set AN/GERC109 are listed below with reference paragraphs covering the specific maintenance functions.

- a. Daily preventive maintenance checks and services (para 31.2).
- b. Cleaning (para 34.1).
- c. Operational checks, (para 33).
- d. Recharging desiccator (para 34).
- e. Replacement of fuses, tubes, vibrator, and antenna lamp (para 34).

31. Preventive Maintenance

Preventive maintenance is the systematic care, servicing and inspection of equipment to prevent the occurrence of trouble, to reduce downtime, and to assure that the equipment is serviceable.

a. *Systematic Care.* The procedures given in paragraph 31.1 and 31.2 cover routine systematic care and cleaning essential to proper upkeep and operation of the equipment.

b. *Preventive Maintenance Checks and Services.* The preventive maintenance checks and services chart (par. 31.2) outlines functions to be performed at specific

intervals. These checks and services are to maintain Army electronic equipment in a combat serviceable condition; that is, in good general (physical) condition and in good operating condition. To assist operators in maintaining combat serviceability, the chart indicates what to check, how to check, -and what the normal conditions are. The References column lists the illustrations, paragraphs, or manuals that contain detailed repair or replacement procedures. If the defect cannot be remedied by the operator, higher echelon maintenance or repair is required. Records and reports of these checks and services must be made in accordance with the requirements set forth in TM38-750.

31.1. Preventive Maintenance Checks and Services Periods

Paragraph 31.2 specifies check and services that must be accomplished daily and under special conditions listed below in transportable and mobile installation

- a. When the equipment is initially installed.
- b. When the equipment is reinstalled after removal for any reason.
- c. At least once each week if the equipment is maintained in a standby condition.

31.2. Daily Preventive Maintenance Checks and Services Chart

| Sequence No. | Item | Procedure | References |
|--------------|-----------------------|--|-----------------|
| 1 | Completeness | Check for completeness of the radio set. | App III. |
| 2 | Publications | See that all publications are complete, serviceable, and current. | DA Pan 310. |
| 3 | Cleanliness | See that the equipment is clean. | Para 34.1. |
| 4 | Cables and connectors | Inspect cables and connectors for cracks and break. | Figs 2 and 8. |
| 5 | Desiccator crystals | Check desiccator crystals for a change from blue to pink. | Para 34b. |
| 6 | Fuse caps, lamps | Check fuse caps and lamps for looseness. | |
| 7 | Battery cable clips | Check battery cable clips for corrosion. | |
| 8 | Telegraph keys | Check telegraph keys for corrosion and loose adjust Fig. 8. | |
| 9 | Insulators | Check insulators for dirt and moisture. | Fig. 7. |
| 10 | Glass | Check meter glass and frequency-indicator glass for breaks and cracks. | Figs. 9 and 10. |
| 11 | Antenna wire | Check antenna wire for corrosion, proper length, and Fig. 8. | |
| 12 | Controls | While making the operational test (item 13), check Fig. 9. | |
| 13 | Operational test | Check the radio set for normal operation. | Para 38. |

32. Visual Inspection

- a. When the equipment fails to operate properly, turn off the power and check. all the items listed below.

Warning

Do not check any item with the power on.

- (1) Wrong settings of controls and switches (para 17).

- (2) Poor connections of cables, headset cord, or antenna lead-in wire.
- (3) Disconnected cables, plugs, or headset cord.
- (4) Grounded or broken antenna or antenna lead-in wire.
- (5) Bad ground connection (para 14).
- (6) Burned-out fuses. (This usually indicates some other fault.)
- (7) Low battery voltage.

b. If the above checks do not locate the trouble, proceed to the operational checklist (para 33).

33. Operational Checklist

a. *General.* The operational checklist assists the operator in quickly locating the source of trouble. The corrective measures are used to repair the trouble. If the measures suggested do not restore normal equipment performance, troubleshooting is required at a higher echelon.

Note on the repair tag what corrective measures were taken and how the equipment performed at the time of failure.

b. *Procedure.* Place the set operation (para 18-21). After the equipment warms up, perform the procedures in c below in the order given. Observe the equipment operation and perform any necessary corrective measures.

c. *Operational Checklist.*

| Action | Normal indication | Corrective measure |
|---|---|---|
| 1. Connect large or small power supply ac cord to ac source. | Ac voltage from 75 to 260 volts. | Check 2 AMP FUSE in large power supply. Check FUSE in small power supply. Check to see that A. C. VOLTS meter movement is not binding or stuck. |
| 2. On large power supply, turn CHARGE-OPERATE switch to OPERATE for operation from 6-volt battery; turn power selector switch to BAT. | Operation of transmitter and receiver. and receptacles. | Check 15 AMP FUSE. Check to see that vibrator hums. Replace if necessary. Check interconnecting power cables |
| 3. On large power supply, turn power selector switch to OFF for operation from hand-cranked generator; connect generator power cable to proper receptacle on unit; crank generator. | Operation of transmitter and receiver. | Check battery for proper voltage and condition of electrolyte. Check interconnecting power cables and connector- receptacle combinations. |
| 4. Depress telegraph key and adjust control (2) for maximum brilliance of exciter lamp (para 20b). | Maximum brightness of lamp | Check transmitter crystal by substitution. Replace oscillator tube, V1, 6AC7 (para 34e). |
| 5. Depress telegraph key and adjust control (3) for maximum brilliance of power amplifier lamp (para 20c). | Maximum brightness of power amplifier lamp. | Replace power amplifier tube V2, 2E26 (para 34). |
| 6. Depress telegraph key and adjust controls (4) and (3) (para 20d and e). | Maximum brightness of antenna lamp and power amplifier lamps. | Check antenna system for shorts and improper connections. Replace antenna lamp (para 34). Replace power amplifier tube V2, 2E26 (para 34). |
| 7. Monitor receiver while advancing GAIN control toward MAX. | Rushing (hissing) sound in headset. | Check PHONES connections. Check headset. Check power source, interconnecting cables, and connector-receptacle combinations. By substitution, check receiver tubes V1, 1T4; V2, 1L6; V3, 1T4; VS, IU5 (para 34f). |
| 8. Tune receiver to transmitter frequency, turn on BEAT OSC control, depress telegraph key, and monitor signal. | Tone appears and disappears as telegraph key is depressed and released, | Check transmitter crystal by substitution. Check transmitter power source, telegraph key contacts, interconnecting cables, and connector-receptacle combinations., Check transmitter and receiver antennas. |

| Action | Normal indication | Corrective measure- |
|---|--|---|
| 9. Adjust BEAT OSC control during cw reception. | Pitch varies with BEAT OSC control rotation. | Check to see that BEAT OSC control is tight on shaft. Replace BFO tube, V6, IT4 (para 34). |

34. Repairs and Adjustments

a. Replacement of Fuses. On the large power supply, the ac line fuse is marked 2 AMP FUSE and the battery supply fuse is marked 15 AMP FUSE. On the small power supply, the ac line fuse is only marked FUSE (rated at 2 amperes). The replacement procedure is identical for all three fuses.

- (1) Rotate the knurled fusecap counterclockwise until it is disengaged from the holder, and extract the fuse from the fuseholder.
- (2) Push the fuse gasket against the fuseholder body.
- (3) Withdraw the fuse from the recession in the fusecap.
- (4) Insert a new fuse of proper value into the fusecap.
- (5) Replace the fuse and cap in the fuseholder, and rotate the cap clockwise until it is tight.

b. Recharging of Desiccator Cartridges.

- (1) Rotate the knurled knob on the desiccator window cover counterclockwise until it is loose from the case.
- (2) Withdraw the brass desiccator cartridge and plug the access hole tightly with a soft clean cloth.
- (3) Unscrew the screened brass cover cap on the opposite end of the desiccator cartridge and pour the desiccant into a clean metallic container. Do not heat the desiccator cartridge.
- (4) Heat the desiccant in a stove, oven, furnace, or fire until it is blue.
- (5) Allow the desiccant to cool until a few grains can be held between the fingers for a short time without causing pain.
- (6) Pour the warm desiccant into the brass desiccator cartridge and replace the screened brass cover cap by rotating it clockwise until it is tight.

- (7) Replace the desiccator cartridge tightly in the case by turning the cartridge clockwise.

c. Replacement of Vibrator in Large Power Supply (fig. 36).

- (1) Use the Phillips screwdriver to turn all control panel retaining screws counterclockwise until they are loose, and then remove them.

Caution

Be careful not to damage the rubber sealing gasket during the following procedure.

- (2) Withdraw the power supply from the case and place the control panel down.
- (3) Remove the 16 screws from the sides of the chassis and remove the bottom cover plate.
- (4) Insert a screwdriver blade between the bottom of vibrator G1 and the i vibrator socket.
- (5) With one hand, use the screwdriver to pry the vibrator from its socket; with the other hand, rock the vibrator out of its socket.
- (6) Orient the socket pins of the replacement vibrator so that the two largest pins fit into socket pins 1 and 6 (nearest the upper right, corner of the vibrator socket supporting bracket) and press the vibrator firmly into place.
- (7) Replace the bottom cover plate and the 16 screws.
- (8) Replace the power supply into its case.
- (9) Replace all panel retaining screws and tighten them firmly with a Phillips screwdriver.

d. Replacement of Power Supply Tubes.

- (1) Remove the case and bottom cover plate from the large power supply, as described in c above, and place the control panel down.

Next printed page is 29.

- (2) Remove voltage regulator tube V1, OB2, located next to the desiccator cartridge (fig. 11), by grasping and pulling it with a slight rocking motion to help ease the tube out.

Warning

The OB2 tube contains radioactive material. Handle carefully to avoid breakage (Cobalt 60 isotope, 0.0067 microcuries).

- (3) In the small power supply the voltage regulator tube can be removed without taking the unit out of its case.
 - (4) Use the open-end wrench supplied, and carefully turn the VR TUBE OB2 (fig. 11) cover cap counterclockwise until it is loose enough to turn by hand. Loosen and remove it.
 - (5) Firmly grasp the short exposed portion of the OB2 with a dry finger-thumb combination and simultaneously rock and pull the tube out of its socket.
 - (6) Carefully align the replacement OB2 pins with the socket holes and press the tube firmly into place.
 - (7) Cover the replacement OB2 with OB2 cover cap, press it down to engage the threads between the control panel and the cover cap, and carefully turn the cover cap clockwise until it is handtight. Tighten it snugly with the open-end wrench.
- e. *Replacement of Transmitter Tubes (fig. 30).*
- (1) Remove the 20 control panel retaining screws by rotating them counterclockwise with the Phillips screwdriver supplied.
 - (2) Remove the desiccator cartridge.
 - (3) Carefully withdraw the chassis from the case and place the control panel down.
 - (4) To remove oscillator tube V1 (type 6AC7, metal tube) loosen the tube retaining band around the base of the tube with a screwdriver blade. Turn the locking screw counterclockwise and remove the screw.
 - (5) Insert the screwdriver blade between the tube base and the socket.
 - (6) Carefully pry the tube from its socket and roll the tube out of the chassis.
 - (7) Align the replacement tube pins with the socket holes.
 - (8) Press the tube into the socket with firm pressure and seat the tube against the socket securely.
 - (9) Insert the locking screw into the hole of the tube-retaining band; then turn the locking screw clockwise with a screwdriver.
 - (10) Tighten the locking screw, in the locking nut, to secure the retaining band around the tube.
 - (11) Removal and replacement of power amplifier tube (type 2E26 glass tube with cap on top) is the same procedure as that used for the exciter tube ((1)-(9) above) except, the plate connector on top of tube type 2E26 must be removed and replaced. Rotate control (3) to zero for sufficient space to remove the plate cap connector.
 - (12) Replace the transmitter in the case; be sure that the desiccator cartridge is at the top of the case.
 - (13) Replace and tighten the control panel retaining screws with the Phillips screwdriver.
 - (14) Replace the desiccator cartridge.
- f. *Replacement of Receiver Tubes (fig. 19).*
- (1) Remove the desiccator cartridge.
 - (2) Remove the 20 control panel screws with the Phillips screwdriver.
 - (3) Carefully withdraw the chassis from the case.
 - (4) Press down on the tube shield and, at the same time, twist counterclockwise.
 - (5) Pull the tube shield up and off the tube.
 - (6) Grasp the tube firmly. Pull and gently rock the tube to remove it from the socket.
 - (7) Insert the replacement tube by orienting the blank pin space on the tube, with the blank space in the socket, are aligned with the pins in the socket, before exerting force to seat the tube in the socket. This is very important because the pins on the miniature tubes are easily bent.

- (9) If the receiver remains inoperative, remove the new tube and put back the original tube. Repeat this procedure with each suspected tube until the defective tube is located.
 - (10) Replace the tube shield by pushing down against the spring tension and turning the tube shield clockwise.
 - (11) Replace the receiver in the case; be sure that the desiccator cartridge hole is at the top of the case.
 - (12) Replace and tighten the control panel retaining screws.
 - (13) Replace the desiccator cartridge.
- g. *Replacement of Transmitter Antenna Lamp (fig. 8).*
- (1) Remove the antenna lamp plastic cover by turning it counterclockwise with the fingers.
 - (2) Remove the lamp by turning it counterclockwise until it springs out.
 - (3) Insert the replacement lamp by orienting the pins on the side of the lamp with the slots in the lamp socket.

- (4) Push the lamp against the tension spring in the socket until the lamp is in place. Turn the lamp clockwise to lock it in place.
- (5) Replace the lamp cover and tighten it with the fingers.

34.1. Cleaning.

Inspect the exterior of the cases. The exterior surfaces must be free of dust, dirt, grease, and fungus.

Warning

Cleaning Compound (FSN 7930-395-9542) is flammable and its fumes are toxic. Provide adequate ventilation. Do not use near a flame.

- a. Remove dust and dirt with a soft, clean cloth. Dampen the cloth with cleaning compound if necessary.
- b. Remove grease, fungus, and ground-in dirt from the cases; use a cloth dampened (not wet) with cleaning compound.
- c. Remove dust and dirt from the jacks and receptacles with a brush.

CHAPTER 5

ORGANIZATIONAL MAINTENANCE

35. Scope of Organizational Maintenance

Organizational maintenance consists of the following:

- a. Quarterly preventive maintenance checks and services (para 38.1).
- b. Troubleshooting by use of the operational checklist (para 33).
- c. Replacing, when necessary, electron tubes, fuses, transmitter antenna lamp, large power supply vibrator, and knobs (para 34).

36. Equipment Required for Organizational Maintenance

- a. Multimeter AN/URM-105.
- b. Test Set, Electron Tube TV-7/U.
- c. Tool Kit, Radio Repair TK-115/G.

37. Preventive Maintenance

a. Preventive maintenance is the systematic care, inspection, and servicing of equipment to maintain it in serviceable condition, prevent breakdowns, and assure minimum operational capability. Preventive maintenance is the responsibility of all echelons

concerned with the equipment, and includes inspection, testing, and repair or replacement of parts, subassemblies, or units that inspection and tests indicate probably would fail before the next scheduled periodic service. Preventive maintenance checks and services of Radio Set AN/GRC-109 at the organizational level are made at quarterly intervals unless otherwise directed by the Commanding Officer.

b. Maintenance forms and records to be used and maintained in this equipment are specified in TM 38-750.

38. Quarterly Maintenance

Quarterly preventive maintenance checks and services on Radio Set AN/GRC-109 are required. Periodic daily services (para 31.2) constitute a part (if the quarterly maintenance checks and services and must be performed concurrently. All deficiencies and shortcomings will be recorded in accordance with the requirements of TM 38-750. Perform all checks and services listed in the quarterly maintenance checks and services chart (para. 37.2) in the sequence listed.

38.1. Quarterly Preventive Maintenance Checks and Services Chart

| Sequence No. | Item | Procedure | References |
|--------------|----------------------------|--|--|
| 1 | Modifications | Determine whether new applicable MWO's have been published. All normal MWO's must be applied immediately; all routine MWO's must be scheduled. | TM 38-750, DA Pam 310-4. |
| 2 | Preservation..... | Check all surfaces for evidence of fungus. Remove rust and corrosion with # 000 sandpaper and paint bare slots. | TM 9-213 |
| 3 | Switches and transformers. | Inspect switches and transformers for looseness. | Figs. 36, 38, and 40. |
| 4 | Tubes and vibrators. | Inspect tubes and vibrators for proper seating. | Figs. 19, 30, and 36. |
| 5 | Resistors | Inspect resistors for cracks, chipping, discoloration, and blistering. | Figs. 21, 23, 24, 26., 31, 32, 38, 41, 43, and 45 |
| 6 | Capacitors | Inspect capacitors for dirt, corrosion, and loose contacts. | Figs. 21, 23, 24, 26, 31 through 34, 36 through 39 and 43. |
| 7 | Variable capacitors | Inspect variable capacitors for dirt and corrosion. | Figs. 19, 21, 25, 30, and 31. |
| 8 | Dry rectifiers | Inspect dry rectifiers for looseness and corrosion. | Figs. 36, 42, 43, 44, and 46 |

39. Troubleshooting by Using Operational Checklist

The equipment operational checklist (para 33) will help maintenance personnel determine whether the radio set is functioning properly. The checklist gives the item to be checked, the normal indication of correct operation, and the corrective measures that can be taken. If the corrective measures given do not fix the defective component, troubleshooting at a higher echelon is required. Note on the repair tag how the component performed.

40. Tube-Testing Techniques

Warning:

The OB2 tube contains radioactive material. Handle carefully to avoid breakage.

When trouble occurs, check the interconnecting power cables, the antenna connections, and the control positions before removing the tubes. If tube failure is suspected, use the applicable procedure below to check the tubes. Refer to paragraph 34 for the instructions on removing and replacing tubes.

a. Use of Tube Tester. Remove and test one tube at a time. Discard a tube only if its defect is obvious, or if the tube tester shows it to be defective. Do not discard a tube that tests at or near its minimum test limit on the tube tester. Reinsert the original tube before testing the next one.

b. Tube Substitution Method. Replace a suspected tube with a new or good tube. If the unit remains inoperative, remove the new tube and put back the original tube. Repeat this procedure with each suspected tube until the defective tube is located.

CHAPTER 6

THEORY

Section I. THEORY OF RADIO TRANSMITTER T-784/GRC-109

41. Relationship Between Units

a. Common Antenna. If a common antenna is used for transmitting and receiving, the receiver is connected to the antenna through a network in the transmitter. Under these conditions, the receiver antenna terminals is shorted directly to ground when the transmitter is keyed.

b. Separate Antenna. When separate antennas are used for transmitting and receiving, the transmitter and receiver have no interrelated functions.

42. Block Diagram (fig. 14)

The signal path in the transmitter is shown in the block diagram (fig. 14) and is discussed in a and below. For complete circuit details, refer to paragraphs 43 through 46 and to the overall schematic diagram (fig. 64).

a. The radiofrequency (rf) signal is generated by crystal oscillator V1. The crystal frequency may be the operating frequency, or one-half, or one-third of the operating frequency. Crystals equal to one-fourth the operating frequency may also be used, but the transmitter output power will be reduced. The necessary doubling, tripling, or quadrupling of the crystal frequency is accomplished in the plate circuit of V1, where the signal is amplified and coupled to power amplifier stage V2.

b. The signal from the oscillator is amplified by V2 and coupled to the antenna. The transmitter is keyed by grounding the cathode returns of V1 and V2.

43. Oscillator (fig. 64)

The oscillator stage is a combination Pierce oscillator and a radiofrequency amplifier-multiplier. The screen grid acts as the anode for the oscillator circuit and the

signal is electron coupled to the plate circuit. A dummy plug, P2, completes certain circuits in the oscillator and power amplifier stages when an external automatic keyer is not used. Although only one crystal is used, two crystal sockets are provided on the front panel to accommodate crystal holders with pins spaced either one-half or three-fourths of an inch.

a. Capacitor C1 blocks the direct current (dc) voltage on the screen grid from the crystal. Resistor R1 develops grid leak bias (with the capacitance of the crystal holder and C1) and returns the control grid to ground. Cathode bias is developed by R2 and C2 when they are grounded through the keying circuit.

b. The plate and screen grid circuits are decoupled from the power supply by the network made up of C7, R6, and R7. Capacitor C3 returns the screen grid to ground for rf, and L5 and R4 form the load for the screen grid circuit.

c. The oscillator plate circuit is tuned by variable capacitor C6 and coils L1 and L2. When band selector switch S1A is in position 1 (3-6 mc), L1 and L2, in series, are connected across C6 through C7. With S1A in position 2 (6-10 mc), a portion of L2 is shorted out. For operation in position 3 (10-17 mc), S1A shorts out L2, so that only L1 is connected across C6. With S1A in position 4 (17-22 mc), the tuned circuit consists of only a portion of L1 connected across C6. Proper tuning of the oscillator is indicated when neon lamp DS1 glows with maximum brightness when the plate circuit is tuned to resonance by C6. Resistor R3 in series with the lamp limits current through the lamp to a safe value. The oscillator signal is coupled to the control grid of power amplifier V2 through capacitor C8.

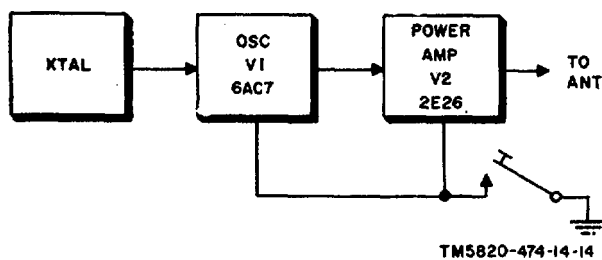

Figure 14. Radio Transmitter T-784/GRC-109, block diagram.

44. Power Amplifier (fig. 64)

a. The power amplifier uses a 2E26 tetrode (V2) in a conventional class C amplifier circuit. Grid leak bias is developed across grid resistor R8. Cathode bias is developed across paralleled cathode resistors R9A and R9B. Radiofrequency choke L6 in series with R8 presents a high impedance load to the signal from the oscillator. It prevents the loss of a large portion of the signal to ground through the relatively small resistance of R8. Capacitor C9 is the cathode bypass. Capacitor C11 is an rf bypass for the common oscillator-power amplifier B+ supply. Screen grid voltage is applied through paralleled voltage-dropping resistors R10 and R11. Capacitor C10 is the screen grid bypass. Paralleled resistor R12 and choke L8 are used to suppress very-high frequency (vhf) parasitic oscillations.

b. A pi network is used for plate circuit tuning and antenna coupling and tuning. The network is composed of C12, coiled L3 or LA (depending on the band being used), and C16. Switch S3 is ganged with C16 so that S3 is closed when tuning low impedance (LO Z) antennas, and open when tuning high impedance (HI Z) antennas. When S3 is closed, C15 is placed in parallel with C16. This arrangement gives a continuously variable output capacity, from 20 to 380 micromicrofarads (uuf), so that a wide range of antenna impedances can be matched by the power amplifier.

c. Antenna tuning lamp DS3 glows with maximum brightness when the antenna is properly tuned. Resistor R13 in parallel with DS3 limits the current through the lamp to a safe value. Capacitor C12 tunes the plate circuit. Neon lamp DS2 glows with maximum brightness when the circuit is at resonance. There is sufficient rf power in the plate circuit so that only one lead of DS2 is connected for an indication of resonance. The capacity to ground of the clipped, unattached lead completes the circuit through the lamp. Coil L3 or LA is selected by S1B and S1C, depending on the band in use. All of L4 is in the circuit for band 1; only a portion is used for band 2. All of L3 is in the circuit for band 3; only a portion is used for band 4. Capacitor C13 is used to couple the signal from the pi network to the antenna, and isolates the antenna from the B+ in the plate circuit. Radiofrequency choke L9 presents a high impedance to the rf currents in the pinet-work to keep them out of the power supply.

45. Receiving Antenna Circuit (fig. 64)

When a common antenna is used for transmitting and receiving, the receiver is connected to the antenna through capacitors C4 and C14 by a jumper from the receiver antenna binding post to J3, the RCVR ANT. post on the transmitter. The input circuit of the receiver is protected from rf power during transmission by the ground through the key. Any rf voltage on C4 when the key is down is shorted directly to ground by the rectifier circuit composed of germanium diodes CR1 and CR2. CR1 conducts on positive voltage peaks; CR2 conducts on negative peaks. When the key is up, rf choke L7, in series with the cathode circuits of V1 and V2, prevents the received signal from being shunted to ground through the low-impedance path in the cathode circuits.

46. Keying (fig. 64) The transmitter is keyed by breaking the cathode circuits of V1 and V2. Normally this is done by the front-panel telegraph key, S2. However, an external key may be connected between EXT. KEY post J2 and ground. In this case, the panel key and the external key are connected in parallel; and

either can be used to operate the transmitter. An automatic high-speed keyer can be connected to the KEYER jack, J1, after removing plug P2. Plug P2 must be in place to operate the transmitter manually. The

parallel combination of resistor R5 and capacitor C5, in series with the cathode circuits of V1 and V2, is a key click filter.

Section II. THEORY OF RADIO RECEIVER R-1004/GRC-109

47. Block Diagram (fig. 15)

a. The receiver can be used for the reception of am, cw, and mcw signals. Fixed-frequency operation is possible by the use of a plug-in front-panel crystal. The signal path is shown in the block diagram and is discussed in b below. For complete circuit details, see paragraphs 48 through 53 and the overall schematic diagram (fig. 63).

b. Signals from the antenna are applied to rf amplifier V1. The amplified output from this stage is coupled to converter V2. The 455-kc converter output is amplified by intermediate-frequency (if.) amplifiers V3 and V4. The amplified if. output is applied to detector-audio amplifier V5. The detector section of V5 demodulates the if. signal, and the resulting audio signal is amplified by the amplifier section of V5. Output from the audio amplifier is applied to the receiver headset binding posts. Beat-frequency oscillator (bfo) V6 supplies the rf signal necessary to produce an audio note during the reception of cw signals, and also generates bias voltage for V1, V3, V4, and V5. The bfo output is coupled to the detector section of V5.

Note

The conditions described in paragraphs 48 and 49 are produced with the RANGE switch in the band 1 position. Operation is identical with the RANGE switch in any of the three positions. Only the values of the components needed to tune the higher frequencies are changed.

48. Radiofrequency Amplifier (fig. 63)

a. Rf amplifier V1 uses a 1T4 pentode operating as a class A voltage amplifier. The signal from the antenna is fed to the primary of antenna coil L1 by segment X of band selector switch S1A rear. Capacitors C1 and C13, which shunt the secondary of L1, limit the highest frequency to which the secondary will tune. Tracking at the high-frequency end of the band is accomplished by adjusting C1; tracking at the low-frequency end is accomplished by adjusting the powdered-iron core of L1. The secondaries of the unused antenna coils are shorted together by S1A front to prevent interaction with the coil in use. Grid bias for V1 is fed through resistor R1 from the receiver bias supply. The gain of the stage is controlled by varying the bias and is dependent on the setting of receiver GAIN control R28. Capacitor C16 prevents rf or if. signals from other amplifier stages from entering the grid circuit of V1 through the bias line.

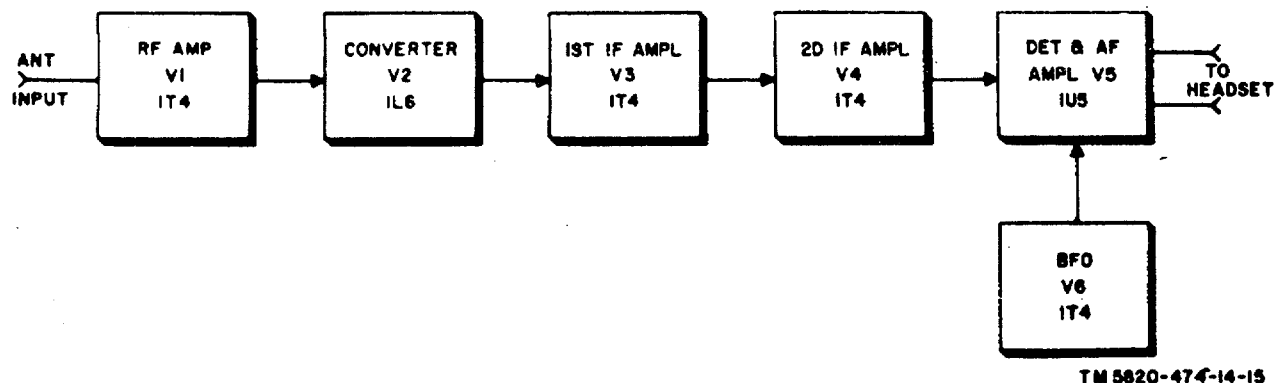

TM 5820-474-14-15

Figure 15. Radio Receiver R-1004/GRC-109, block diagram.

b. The rf signal developed across the secondary of L1 is fed to the grid of V1 through segment Y of S1A rear. The grid circuit is tuned to the signal frequency by C10, a section of the main tuning capacitor. Capacitor C17 bypasses any rf currents in the filament circuit of V1, to ground. Screen voltage is dropped to the proper value by R2. Capacitor C18 bypasses rf currents in the screen voltage, to ground. Capacitor C45 is an rf bypass filter for the B+ supply.

c. The plate circuit is tuned to the incoming signal frequency by C11. Section S1B rear connects L4 across C11. Tracking at the high end of the band is accomplished by adjusting C4; tracking at the low end is adjusted by turning the powdered iron core in L4A. The unused plate circuit coils are shorted together by S1B front to prevent interaction with the coil in use. Resistor R3 and capacitor C19 form a plate-decoupling network. The amplified signal is coupled to the converter through capacitor C20.

49. Converter (fig. 63)

a. Converter V2 uses a 1L6 pentagrid tube to produce a 455-kc output from the mixing of the input signal and the oscillator signal. The oscillator section may be operated as a variable frequency oscillator or as a crystal-controlled oscillator for fixed-frequency operation.

b. The signal from V1 is applied to the signal grid (pin 6) of V2. Grid leak bias is developed across resistor R4. Capacitor C22 and choke L12 form a filter circuit to prevent rf signals from entering the filament line. Screen grid voltage is dropped to the proper value by thermistor RT6, which helps stabilize the circuit. Capacitor C23 is the screen grid bypass. Resistor R8 and capacitor C26 form a plate decoupling network. The 455-kc if. signal is inductively coupled to the first if. amplifier through T1. Capacitors C24 and C64 resonate the primary of T1 to the if frequency; tuning adjustments

are made by turning the powdered-iron cores inside the transformer.

c. When the oscillator section of the converter is continuously tunable, segments X and Y of S1C rear select the proper oscillator coil for the band in use. Section S1C front shorts out the unused grid windings. The plate coil of L7 is an untuned tickler winding that provides feedback to the oscillator grid. The oscillator plate (pin 3) receives its voltage through thermistor RT27 and the tickler winding. Capacitor C59 and RT27 form a decoupling circuit. Without a crystal in crystal socket XY1, R7 is shorted out of the circuit. The grid winding of L7 is shunted by trimmer capacitor C7, which is used to adjust oscillator tracking at the high end of the band. Tracking at the low end of the band is accomplished by turning Use powdered iron cord in L7. Capacitor C12 is the main oscillator tuning capacitor. Grid leak bias for the oscillator is provided by the paralleled resistor RS-capacitor C21 combination in series with resistor R18. Capacitor C42 is an rf bypass.

d. Placing a crystal in crystal socket XY1 converts the oscillator to a conventional Pierce oscillator with the crystal connected directly between the oscillator grid (pin 4) and anode (pin 3). Capacitor C21 is removed from the circuit and capacitors C55 and C56 are added. Resistor R7 is placed in series with the oscillator plate B line. Grid leak bias is developed by the combination of C7, R18, and C42. Resistor R7 isolates the plate tickler coils from the circuit. Capacitors C55 and C56 are added to provide better control over oscillator excitation.

50. First If. Amplifier (fig. 63)

First if. amplifier V3 uses a 1T4 pentode as a voltage amplifier for the 455-kc signal from the converter. The signal is inductively coupled to the secondary of if transformer T1. The transformer secondary is tuned to resonance by paralleled capacitors C25 and C65. Grid bias is supplied through resistor R9 from the bias supply. Capacitor C27 and R9 decouple the

grid circuit from the common bias line. The gain of V3 is determined by the setting of GAIN control R28. Screen grid voltage is dropped to the proper value by resistor R10. Capacitor C28 is the screen grid bypass. Resistor R11 and capacitor C31 form a plate circuit decoupling network. The amplified if. signal is fed from the plate of V3, to the primary of if. transformer T2. The primary of T2 is tuned to resonance by fixed capacitors C29 and C61; tuning adjustments are made by adjusting the powdered-iron cores in T2.

51. Second If. Amplifier (fig. 63)

Second if. amplifier V4 is identical in function and operation to the first if. amplifier. There are two physical differences between the stages. The 10-uuf padding capacitor (C63), across the secondary of T2, is mounted outside of the transformer can. The primary of T3 is tuned to resonance by a single capacitor, C34, rather than two capacitors.

52. Defector-Af Amplifier (fig. 63)

Detector-audiofrequency (af) amplifier V5 uses a 1U5 diode-pentode to demodulate the if. signals, and to amplify the resulting audio to drive the receiver headset. The if. signal from V4 is inductively coupled to the secondary of T3. Capacitors C35 and C62 resonate the secondary to 455-kc. Rectification of the if. signal takes place at the diode (pin 4) of V5. The resulting audio voltage is developed across diode load resistors R15 and R16. Capacitors C37 and C38 filter out the 455-kc component of the rectified signal. The audio signal is coupled to the grid (pin 6) of the pentode section by C39. Grid bias is supplied through resistor R17 from the junction of voltage divider resistors R21 and R22 in the bias supply line. Paralleled capacitors C41 and C58 provide filtering for the power supply, and are audio bypasses for the screen grid circuit. The amplified audio signal from the plate is coupled to the headset binding posts by output transformer T4. The transformer provides a 4,000-ohm output impedance at the PHONES jacks J3 and J4. Capacitors C40 and C57

short-circuit audio frequencies above 3,000 cycles per second (cps), because these frequencies add little to the intelligibility of voice signals, and can be the source of noise.

53. Beat-Frequency Oscillator (fig. 63)

a. The bfo uses a triode-connected 1T4 (V6) pentode in a Hartley oscillator circuit, to supply the signal necessary to make cw signals audible. The output of the bfo is also rectified to produce bias voltage for V1, V3, V4, and V5. Since bias is necessary whether am., mcw, or cw signals are being received, the bfo functions continuously. When signals other than cw are being received, the bfo is tuned to a frequency high enough to make the beat note inaudible.

b. Plate voltage for V6 is obtained from the power supply through voltage-dropping resistor R23 and the center tap of L10, the oscillator coil. Capacitor C49 is an rf bypass and places the center tap of L10 at rf ground potential, permitting the rf voltage on the plate and grid to be in phase to sustain oscillations. The frequency of oscillation is determined by capacitor C50 in parallel with series capacitors C51 and C52, and L10. The bfo frequency can be shifted slightly on each side of the 455-kc if. frequency by adjusting C52 to obtain the desired beat note. When the BEAT OSC: control is in the OFF position, the plates of C52 short together and remove the capacitor from the circuit. The bfo frequency is then sufficiently high to make the beat note inaudible. Operating bias is developed by C54 and R25. Capacitor C54 provides a positive feedback path from the plate circuit to the grid circuit. Choke L11 prevents the bfo signal from being fed into the filament line. Stray capacitances couple the bfo output to the diode section of V5 where mixing of the received signal and the bfo signal takes place.

c. Germanium diode CR1 rectifies the bfo output to provide the bias supply. Capacitor C48 blocks the plate voltage from the rectifier circuit.

The pulsating negative dc voltage from CR1 is filtered by resistor R24 and capacitor C47, and then is fed to voltage-dividing circuits. Fixed bias for V5 is obtained from the junction of resistors R21 and R22. A variable bias voltage for V1, V3, and V4 is obtained from potentiometer R28, the receiver GAIN control, in series

with R26. Capacitor C46 is an rf bypass for the grid bias line. BAT. OFF switch S2, mounted on the rear of the gain control, is the receiver on-off switch. It disables the receiver by disconnecting the filament voltage. Capacitor C53 is a bypass filter for the filament line.

Section III THEORY OF POWER SUPPLY PP-2684/GRC-109

54. Block Diagram (fig. 16)

a. Power Supply PP-2684/GRC-109 furnishes B+ and filament voltages to operate the transmitter and the receiver. The large power supply can be operated from either of three primary power sources:

- (1) Ac lines that furnish 75 to 260 volts, 40 to 400 cycles.
- (2) Six-volt storage battery.
- (3) Hand-cranked generator. When operated from ac lines, the power supply can also be used to charge a 6-volt storage battery. The modes of operation are shown in the block diagram and discussed in b through e below. For complete circuit

details, refer to paragraphs 55 through 58 and the overall schematic diagram (fig. 65).

b. When operated from ac lines, power transformer T1 steps up the line voltage for the transmitter and receiver B+ supplies, and steps down the line voltage for the transmitter and receiver filament supplies. High voltage from the secondary of T1 is rectified by rectifiers CR1 through CR4, and is filtered to provide 450 volts for transmitter B+. Rectifiers CR1 and CR3 of the bridge circuit also operate to provide 108 volts receiver B+ after regulation by V1 and filtering. Transmitter filament voltage of 6.3 volts ac is taken from a separate secondary winding on T1.

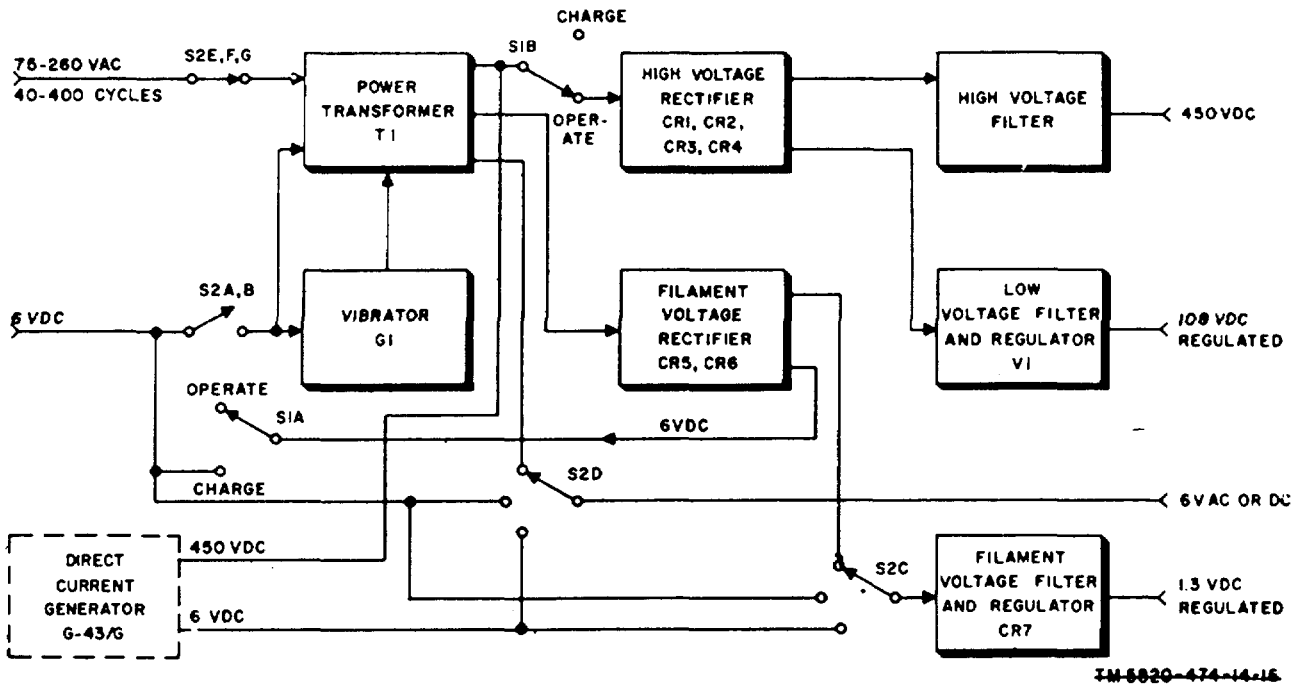

Figure 16. Power Supply PP-2684/GRC-109, block diagram.

The rectifier filament voltage is derived from an additional secondary winding on T1. The voltage is rectified by rectifiers CR5 and CR6, filtered, and then regulated by selenium rectifier CR7. The output is 1.3 volts dc.

c. When operated from a 6-volt storage battery, vibrator G1 is connected across the vibrator winding on the primary of T1. An ac voltage appears in the secondary. Transmitter and receiver B+ voltages are rectified, filtered, and regulated as they are when the power supply is operated from the ac line. Transmitter filament voltage is taken direct from the storage battery. A portion of the battery voltage is filtered, and then regulated by CR7 to supply the receiver filaments.

d. When the power supply is operated from the hand-cranked generator, T1 is bypassed and the 450-volt dc generator output is applied at the input to the rectifier circuit. The transmitter and receiver B+ voltages are treated as they are when the power supply is operated from the ac line. The 6-volt dc generator output is supplied directly to the transmitter filaments; a portion of this voltage is filtered, then regulated by CR7 to supply the receiver filaments.

e. When the large power supply is used for battery charging. CHARGE-OPERATE switch S1 must be in the CHARGE position. The ac line voltage is stepped down by T1 and rectified by CR5 and CR6. The dc charging voltage is applied through S1A to the positive 6-volt battery terminal.

55. AcLine Operation (fig. 65)

a. Ac voltage is fed to the primary of T1 through plug P3, fuse F2, and pins 1 and 2 of the chassis-panel disconnect combination plug P7 and jack J1. Fuse F2 protects T1 if power selector switch S2 is set at a lower value than that of the ac line voltage. Ac voltmeter M1 is connected directly across the ac line to indicate line voltage. The meter is used to determine the proper voltage setting for S2. Capacitors C12 and C13, connected across the ac line, filter any rf interference from the power source.

b. There are three primary windings on T1. One of the primary windings (black, blue-white and black leads) is the vibrator winding and is not used for ac operation. Proper taps, depending on the line voltage, are selected on the two primary windings selected by S2E, S2F, and S2G. The windings are connected in series for operation a from 150-, 180-, 220-, and 260-volt lines, and in parallel for operation from 75-, 90-, 110-, and 130-volt lines. The voltage is stepped up by the high-voltage secondary and rectified by selenium rectifiers CR1, CR2, CR3, and CR4, a full-wave, bridge rectifier circuit. The pulsating dc output from the bridge is filtered by the series parallel combination of electrolytic capacitors C4A, C4B, C5A, and C5B, and then fed to pin 3 of the TRANS PWR. plug P4. Resistors R8 and R9 equalize the voltage distribution across the electrolytic capacitors. Radiofrequency choke L1 is used to suppress radiofrequency interference (hash) caused by sparking at the vibrator contacts when the vibrator is in use.

c. Receiver high voltage comes from the same winding on T1 as the transmitter high voltage. Rectifiers CR1 and CR3 operate as a full-wave rectifier circuit in addition to their function in the bridge rectifier circuit. Output voltage is taken from the center tap of the high-voltage winding. This voltage is approximately one-half the value of that obtained at the output of the bridge rectifier circuit. Filtering of the pulsating dc is done by electrolytic capacitors C7A and C7B, and resistor R6. Resistors R5 and R6 are shorted out by the jumper inside the cover of HAND GEN. INPUT plug P6. The voltage is held at 108 volts by V1, an OB2 gas-filled voltage-regulator tube. Resistor R7 prevents V1 from acting as a low frequency relaxation oscillator. Rf choke L5 is used for hash suppression. The regulated voltage is fed to pin 3 in the RCVR PWR plug P5.

d. Receiver filament voltage is derived from a separate secondary winding on T1. To produce filament voltage, the ac from a winding on T1 is rectified by selenium rectifiers CR5 and CR6 in a full-wave rectifier circuit. The rectified voltage is

taken from the center tap of the transformer winding and fed through S1A, voltage-dropping resistor R3, S2C, and voltage-dropping resistor R4 to the input of the filter-regulator circuit. Filtering is accomplished by electrolytic capacitors C8 and C9 and filter choke L2. The filtered voltage is regulated at 1.3 volts by selenium rectifier CR7 and fed to pin 4 of RCVR PWR plug P5.

e. Transmitter filament voltage is obtained from a 6.3-volt secondary winding on T1. The voltage is fed through S2D to pin 5 of TRANS PWR plug P4. Capacitor C11 is a hash filter that prevents rf interference from the vibrator when used. The 6.3-volt winding of T1 is used only when the power supply is operated from ac lines.

56. Storage Battery Operation (fig. 65)

a. When the large power supply is operated from a 6-volt storage battery, power selector switch S2 must be in the BAT. position. The battery is connected to the 6 VOLT INPUT battery cables P1 and P2. Current flows through fuse F1 and pin 3 of the panel-chassis disconnect combination J1 and P7, to S2B, S2C, and S2D. Capacitor C14 is a filter that prevents hash from being radiated through the positive battery cable. Battery voltage on S2B is fed through a hash filter circuit composed of capacitors C1 and C2 and choke L4, and then to the center tap of the vibrator winding on T1. The two primary windings used when operating from ac lines are disconnected by S2E and S2G. Vibrator G1 is connected across the vibrator winding by S2A. The vibrator rapidly interrupts the battery current in the vibrator winding at regular intervals. This results in square wave dc pulses which cause an ac voltage to be developed in the secondary. The induced voltage is then rectified, filtered, and regulated as it is during operation from the ac lines. Resistors R1 and R2 are damping resistors that reduce sparking at the vibrator contacts and assist in the elimination of radiated hash. Capacitor C3 across the high-voltage secondary of T1 is

a buffer capacitor that absorbs voltage surges which occur when the vibrator breaks the primary current. When the primary current is broken, the primary magnetic field collapses very rapidly and induces a very-high voltage in the secondary.

b. Battery voltage at S2D is fed directly to pin 5 of TRANS PWR plug P4 for the transmitter filaments. Receiver filament voltage is taken from the battery voltage applied to S2C. The voltage is fed through voltage-dropping resistor R4 and the filter-regulator circuit composed of C8, L2, C9, and CR7, to pin 4 of RCVR PWR plug P5.

57. Hand-Cranked Generator Operation (fig. 65)

a. To operate the large power supply from the hand-cranked generator, power selector switch S2 must be in the OFF position. This disconnects the primaries of T1, which are not used in this mode of operation. Removing the cover of the HAND GEN. INPUT plug P6 disconnects the jumper across resistor R5 and places the generator in the circuit.

b. The 450-volt dc input from the hand cranked generator is fed through pin 3 of P6 to the junction of rf choke L3 and resistor R5. Transmitter B+ is thus fed to the center tap of the high-voltage winding of T1, and then passes through selenium rectifiers CR2 and CR4. The rectifiers offer little resistance to the dc voltage. The voltage is filtered before being fed to pin 3 of P4.

c. Receiver B+ is also obtained at the junction of L3 and R5. Resistor R5 drops the voltage to the proper value for the receiver. The voltage is then filtered and regulated in the same manner as when the power supply is operated from ac lines.

d. Hand-cranked generator 6-volt dc filament power input is fed into pin 5 of P6, and then to S2C and S2D. The voltage on S2D is fed to pin 5 of TRANS. PWR. plug P4. The voltage on S2C is fed to voltage dropping resistor R4, and then filtered and regulated in the same manner as when the power supply is operated from ac lines.

58. Battery-Charging Operation

When the large power supply is used for charging a 6-volt storage battery, CHARGE-OPERATE switch S1 must be in the CHARGE position. Power selector switch S2 must be in the correct position for the ac line voltage being used. The high-voltage secondary is

disconnected from the circuit by S1B and S1C. Resistor R10, a current-limiting resistor, is placed in the charging circuit by S1A. Selenium rectifiers CR5 and CR6 rectify the charging current which is fed through R10 to the positive battery cable, P2.

Section IV. THEORY OF POWER SUPPLY PP-2685/GRC-109

59. Block Diagram (fig. 17)

a. Power Supply PP-2685/GRC-109 furnishes B+ and filament voltages to operate the transmitter and the receiver. Voltages supplied to the receiver are regulated. The small power supply operates from ac lines only, 75 to 260 volts, 40 to 400 cycles. For complete circuit details, see paragraph 60 and the overall schematic diagram (fig. 66).

b. Power transformer T1 steps up the line voltage for B+ supplies, and steps, it down for filament supplies. High voltage from T1 is rectified by CR1 through CR4, and filtered to provide 450 volts for transmitter B+. Rectifiers CR1 and CR3 also operate to provide 108 volts receiver B+ after filtering and regulation by V1. Transmitter filament voltage is 6.3 volts ac from T1.

Receiver filament voltage is also derived from T1. The voltage is rectified by rectifiers CR6 and CR7, filtered, and regulated by rectifier CR5 to provide 1.3 volts dc.

60. Circuit Analysis (fig. 66)

a. Ac voltage is fed to the primary of power transformer T1 through line cord plug P3 and fuse F1. Fuse F1 protects T1 in the event input power selector switch S1 is set at a lower value than that of the ac line voltage. Ac voltmeter M1 is connected directly across the ac line and indicates the line voltage. The meter is used to determine the proper voltage setting for switch S1. b. Proper taps of the two primary windings of T1 are selected by S1, depending on the voltage of the ac line.

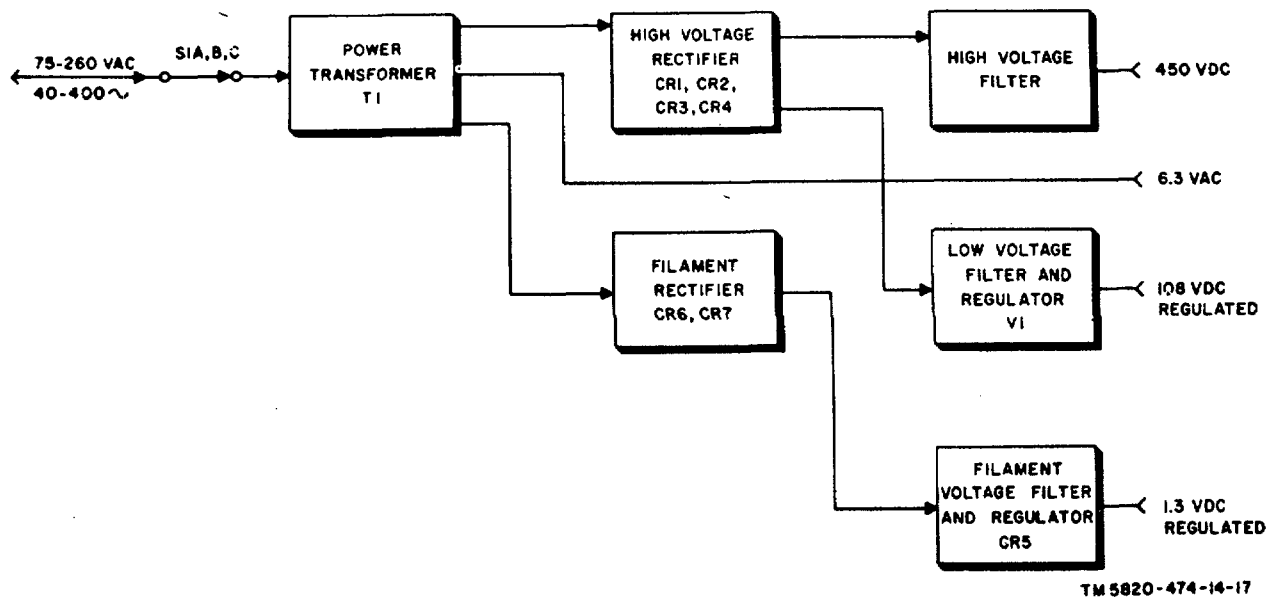

Figure 17. Power Supply PP-2685/GRC-109, block diagram.

The windings are connected in series for operation from 150-, 180-, 220-, and 260-volt lines. They are connected in parallel by S1B for operation from 75-, 90-, 110-, and 130-volt lines. The primary voltage is stepped up by the high-voltage secondary of T1 and rectified by selenium rectifiers CR1, CR2, CR3, and CR4, a full-wave bridge rectifier circuit. The pulsating dc output from the bridge is filtered by a single electrolytic capacitor, C5, and fed to pin 3 of TRANS PWR plug P1.

c. Receiver B+ comes from the same high-voltage winding of T1 as the transmitter B+. Rectifiers CR1 and CR3 operate as a full-wave rectifier circuit, in addition to their function in the bridge-rectifier circuit. The pulsating dc voltage is approximately one-half the value of that obtained from the bridge-rectifier circuit. Filtering is by electrolytic capacitors C1 and C2, and resistor R2. The voltage is regulated at approximately 108 volts by V1,

and OB2 gas-filled voltage-regulator tube. Resistor R3 prevents V1 from acting as a low-frequency relaxation oscillator. the regulated voltage is fed to pin 3 of PCVR PWR plug P2.

d. Transmitter filament voltage is obtained -from a 6.3-volt secondary wing on T1. The voltage is fed directly to pin 5 of TRANS PWR plug P1. Filament voltage for the receiver comes from a separate secondary winding. The voltage is rectified by CR6 and CR7 in a full-wave rectifier circuit. The pulsating dc is taken from the center tap of the transformer winding and fed through voltage-dropping resistor R1 to the input of the filter-regulator circuit. Filtering is by electrolytic capacitors C3 and C4, and filter choke L1. The filtered voltage is regulated at 1.3 volts by selenium rectifier CR5 and fed to pin 4 of RCVR PWR plug P2.

CHAPTER 7

TROUBLESHOOTING

Note:

All troubleshooting procedures may be performed by third or fourth echelon personnel.

Section I. GENERAL TROUBLESHOOTING TECHNIQUES

Warnings:

1. Be extremely careful when servicing the power supplies and transmitter because voltages above 450 may be present. Do not contact the ac lines when connecting power supplies; voltages up to 260 may be encountered.
- 2, When selenium rectifiers fail because of burnout or arc-over, poisonous fumes and compounds are released, The fumes have a strong odor and must not be inhaled. Provide adequate ventilation. Do not handle the rectifier until it has cooled.

61. General Instruction

Troubleshooting at field and depot maintenance level includes all the techniques outlined for organizational maintenance, and any special or additional techniques required to isolate a defective part. The field maintenance procedures are not complete in themselves, but supplement the procedures described in the organizational maintenance section of this manual. The systematic troubleshooting procedure, which begins with the operational and sectionalization checks that can be performed at an organizational level, must be completed by means of localizing and isolating techniques.

62. Organization of Troubleshooting Procedures

a. General. The first step in servicing a defective radio set is to sectionalize the fault. Sectionalization means tracing the fault to a major component. The second step is localization. Localization means tracing the fault to a defective stage or circuit of the major component. The defective part responsible for the abnormal operation is then isolated by voltage, resistance, and continuity checks. Some faults, such as burned-out resistors, and arcing and shorted transformers, can often be located by sight, smell, and hearing. The majority of faults, however, must be isolated by checking voltages and resistances.

b. Sectionalization. Radio Set AN/GRC-109 consists of a transmitter, a receiver, and two power supplies. Only one of the power supplies is required to operate the receiver and transmitter. The first step in

tracing trouble is to locate the component at fault by the following methods:

- (1) *Visual inspection.* The purpose of visual inspection is to locate faults without testing or measuring circuits.
- (2) *Operational tests.* Operational tests may indicate the component at fault. In some cases, they will help to determine the specific fault. The checklist given in paragraph 33 is an operational test.

c. Localization. The tests listed below will aid in localizing the trouble to a single stage or circuit of a component.

- (1) *Troubleshooting charts.* The troubleshooting charts (para 66, 73, 79, and 83) give a systematic method of locating malfunctioning circuits.
- (2) *Signal substitution.* Signal substitution charts (para 67), when used in conjunction with the troubleshooting chart, provide a method of localizing trouble to a particular stage of the receiver.

d. Isolation. The defective part is usually located by voltage and resistance measurements. The voltage and resistance charts (fig. t8 and 35) will aid in locating the defective part in the receiver and transmitter. Take readings and compare them with normal readings on the chart. Consult the overall schematic diagrams when taking voltage and resistance readings in the power supplies.

Note

During these tests, the possibility of intermittent troubles should not be overlooked. If present, this type of trouble often may be made to reappear by tapping the components.

63. Test Equipment Required

The following chart lists the test equipment required when troubleshooting Radio Set AN/GRC-109. The associated technical manuals and the assigned common names are also listed.

| Test equipment | Technical manual | Common name |
|---|-------------------------|----------------------|
| Test Set, Electron Tube TV-7/U | TM 11-6625-274-12 | Tube tester |
| Multimeter 1U-26/U | TM 11 6625-200-12 | Vtvm |
| R. F. Signal Generator AN/URM-25A | TM 11-5551A | Rf signal generator |
| Audio Oscillator TS-382A/U | TM 11-6625-261-12 | Audio oscillator |
| Wattmeter AN/URM-120 | TM 11-6625-446-15 | Wattmeter |
| Variable Transformer CN-16/U | | Variable transformer |
| Multimeter TS-352/U | TM 11-5527 | Multimeter |

Section II. TROUBLESHOOTING RADIO RECEIVER R-1004/GRC-109

Caution

Do not attempt removal or replacement of parts before reading the instructions given in paragraph 87.

64. Checking Receiver Filament and B+ Circuit for Shorts

a. *When to Check.* When either of the following conditions applies, check for short circuits and clear the trouble before applying power.

- (1) When the receiver is being serviced apart from other units of Radio Set AN/GRC-109 and the nature of the abnormal symptoms is not known.
- (2) When abnormal symptoms reported from operational tests indicate the possibility of

a short circuit in the filament or B+ circuits.

b. *Conditions for Tests.* To prepare for the short-circuit tests, perform the following. procedures:

- (1) Remove the receiver from its case.
- (2) Remove all tubes.

c. *Measurements.* Make the resistance measurements indicated in the following chart. If abnormal readings are obtained, make the additional isolating checks outlined. When the faulty part is found, make repairs before applying power.

Short-circuit tests

| Point of measurement | Normal resistance | Isolating procedure |
|--|--------------------------|---|
| Between pins 2 and 3 of power Plug P1 (fig. 18). | Approximately 15 megohms | If resistance is zero, check for shorted capacitor C40, C41, C45, or C58 (fig. 24 and 27), or for short-circuited B+ wiring. If resistance is low, check for leakage in one of above capacitors or other shorted capacitor in one of plate or screen grid circuits, or in C49 (fig. 21) in bfo assembly (fig. 19). |
| Between pins 2 and 4 of power plug P1 (fig. 18). | Infinite | If resistance is zero, check for shorted capacitor C17, C22, or C53 (fig. 24 and 27), or for short-circuited filament wiring. |

65. Test Setup (fig. 18)

a. Bench tests of the receiver require connection to a power source and to various test equipments. The power source must be connected to the receiver for all dynamic servicing procedures. The test equipment connections vary from test to test.

b. Either the large or small power supply is the most convenient power source for use : in receiver bench tests. If either is available, connect the receiver power cable to the RCVR PWR jack on the power supply. If one of these is not available, use a power source capable of supplying 108 volts dc at 20 milliamperes (ma) (regulated) and 0.3 volts dc at 300 ma (regulated).

66. Localizing Troubles

a. *General.* The procedures are outlined in the following chart for localizing troubles to the af, if., and rf sections of the receiver, and for localizing troubles to a stage within the various sections. Parts locations are shown in figures 19 through 27. Figure 22 shows the rf-if chassis. Various views of this chassis are shown in

figures 23 through 26. One or more of the localizing procedures may be necessary, depending on the nature of the operational symptoms. When the trouble has been localized to a particular stage, use the techniques outlined in paragraph 68 to isolate the trouble to a particular j part.

b. *Use of Chart.* The troubleshooting chart (d below) supplements the operational checks detailed in paragraph 33. If the previous operational checks have resulted in a symptom listed in this chart, go direct to the symptom.

Caution: If the operational symptoms are not known, or if they indicate the possibility of short circuits within the receiver, make the short-circuit checks described in paragraph 64 before applying power.

c. *Conditions for Tests.* All the checks outlined in the chart are to be conducted with the receiver connected to a power source as described in paragraph 65.

d. *Troubleshooting Chart.*

| Item | Symptom | Probable trouble | Procedure |
|------|--|---|---|
| 1 | No output or hum | Defective audio stage | Check V5 (fig. 19). Make voltage and resistance measurements on XV5 (fig. 28). Check C57 (fig. 19) and secondary of T4 (terminals 3 and 4) (fig. 27). |
| 2 | No output; slight hum | Defective headset..... Defective detector section of V5. | Check headset by substitution. Check V5. Make voltage and resistance measurements on XV5 (fig. 28). |
| 3 | Weak output, and no change in output when receiver is tuned. | Receiver misaligned | Align receiver (para 89). |
| 4 | No output when 455-kc modulated signal is applied to pin 6 of V3 (fig. 19 and 27). | Defective first or second if. stage..... | Check V3 and V4. Make voltage and resistance measurements on XV3 and XV4 (fig. 28). Make signal substitution tests (para 67). |
| 5 | Rushing noise, but no signal output. | Defective rf or oscillator stage | Check V1 and V2. Make voltage and resistance measurements on XV1 and XV2 (fig. 28). Make signal substitution tests (para 67). |
| 6 | No output on one band; other two bands normal. | Defective oscillator coil | Check L7, L8, or L9 (fig. 25), depending on defective band. |
| 7 | Low output on one band; other two bands normal. | Defective antenna coil | Check L1, L2, or L3 (fig. 25), depending on defective band. |
| 8 | No bfo action; no control of receiver gain. | Defective bfo stage | Check V6. Make voltage and resistance measurements on XV6 (fig. 28). |
| 9 | Normal bfo action; no control of receiver gain. | Defective bias rectifier | Check CR1 (fig. 21) by substitution |

| Item | Symptom | Probable trouble | Procedure |
|------|---|----------------------------------|--|
| 10 | No bfo action; normal control of receiver gain. | Defective bfo stage | Check alignment of L10 (fig. 21 and para 92). See that C52 does not remain shorted throughout its rotation. |
| 11 | Receiver noisy while being tuned to various stations. | Dirty plates in tuning capacitor | Clean between plates of ganged tuning capacitor. |
| 12 | Excessive distortion when listening to am. stations. | Leaky audio coupling capacitor | Check C39 (fig. 27) for leakage. |

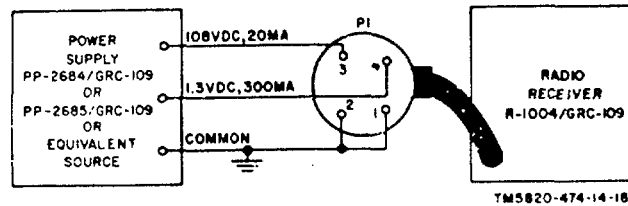

Figure 18. Test setup for troubleshooting receiver.

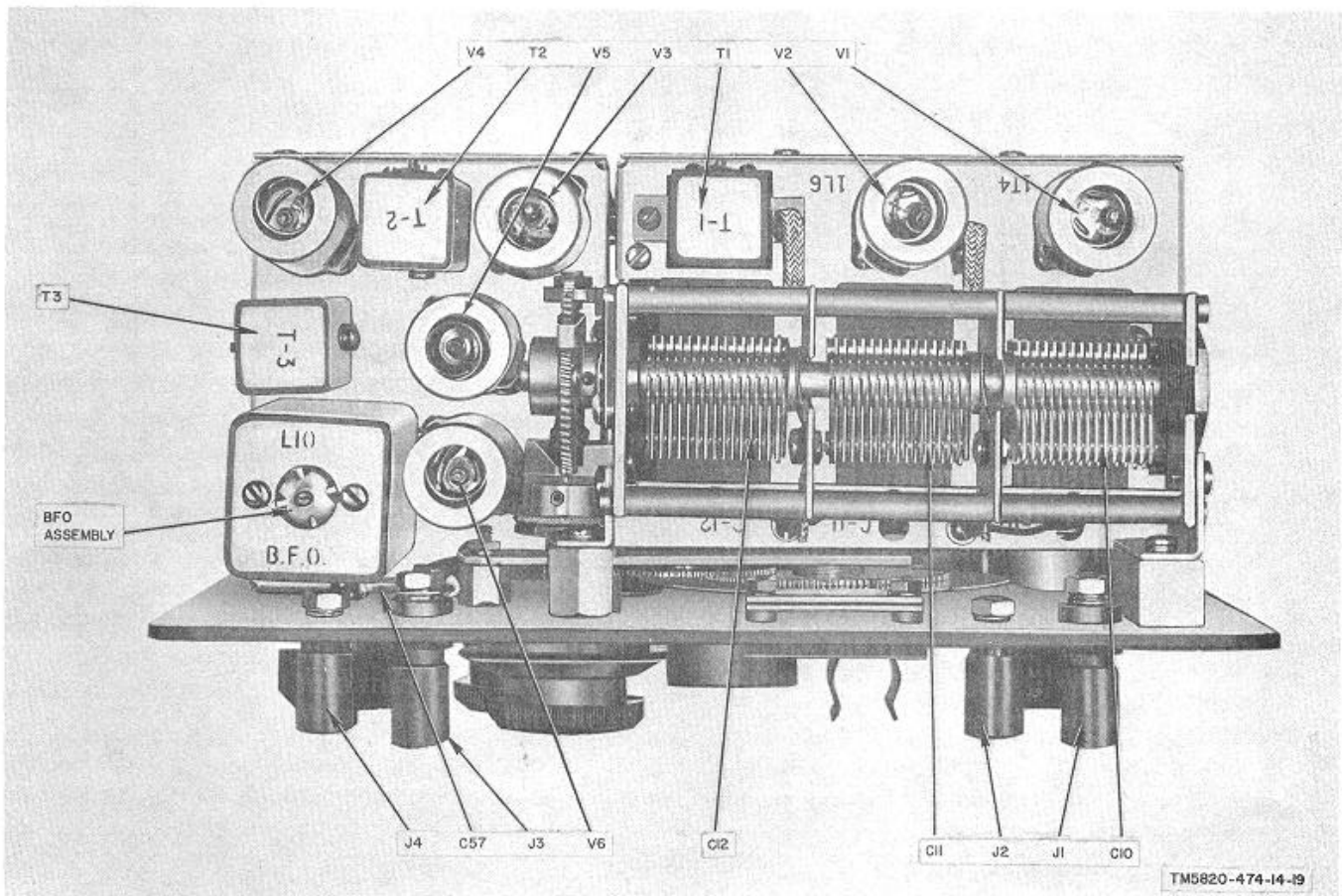

Figure 19. Receiver, top of chassis.

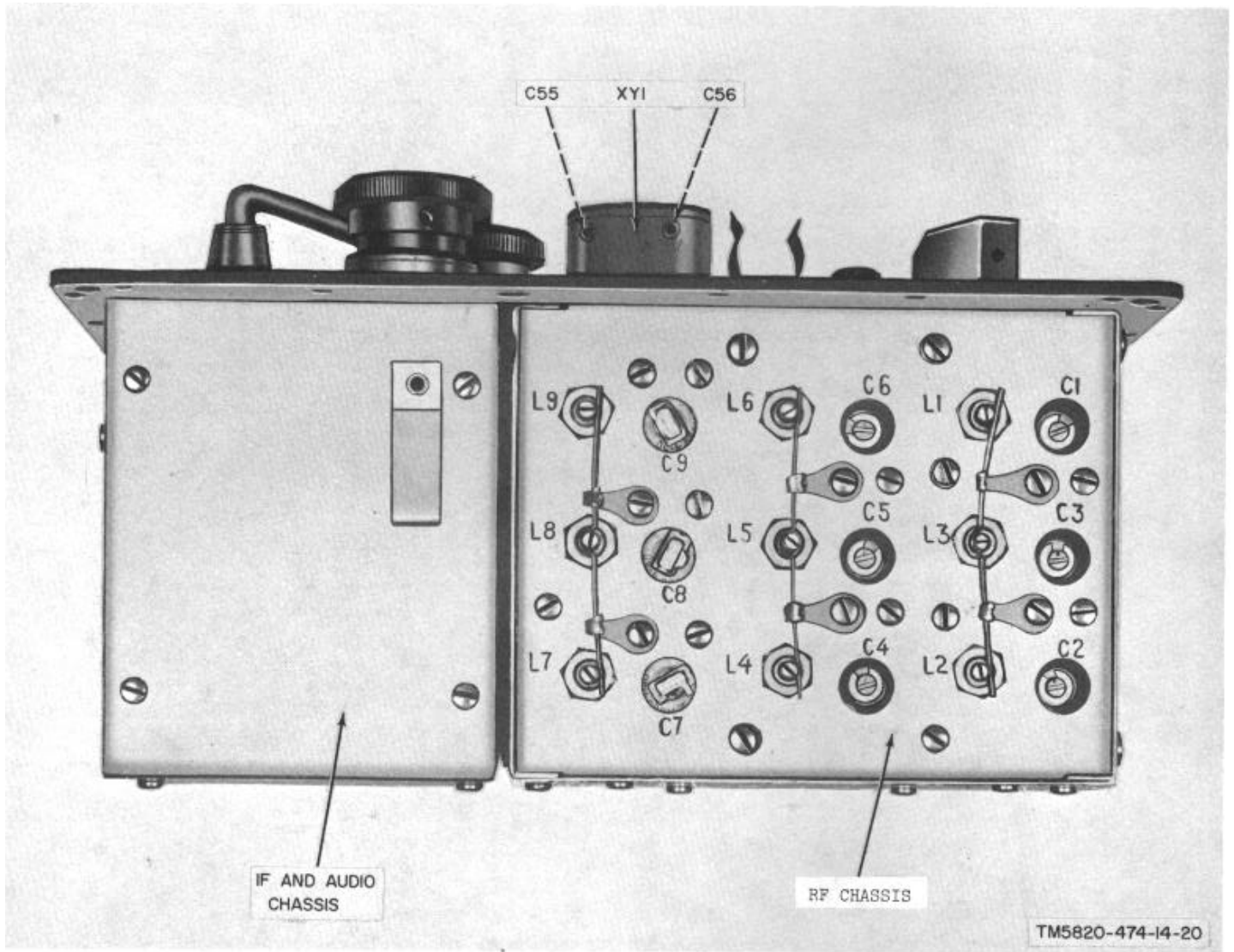

Figure 20. Receiver, bottom of chassis.

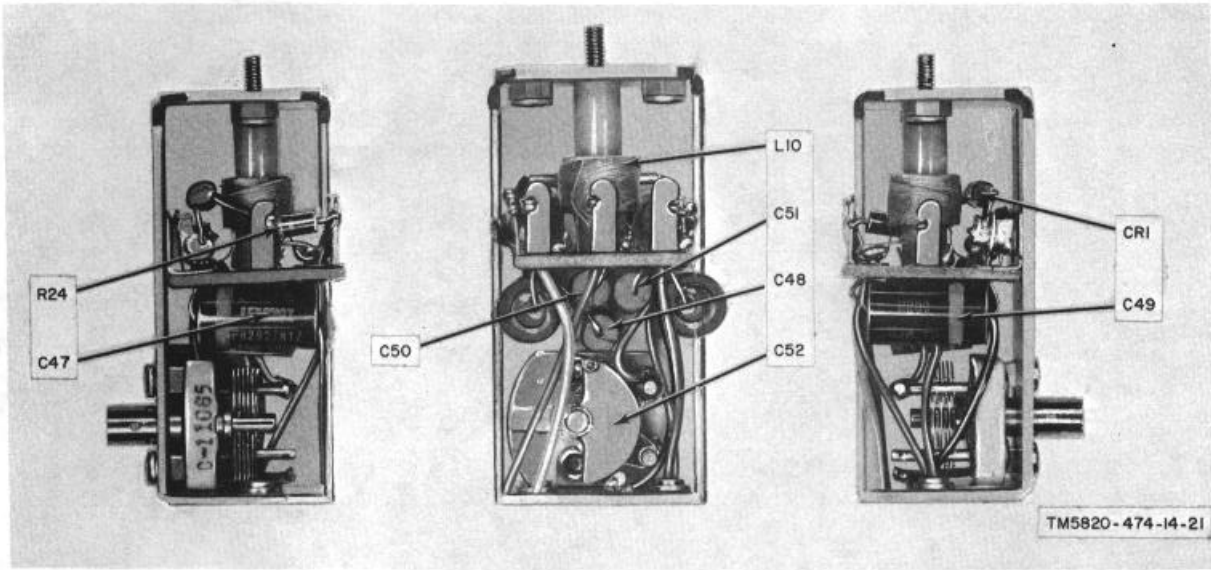

Figure 21. Receiver bfo assembly, cover removed.

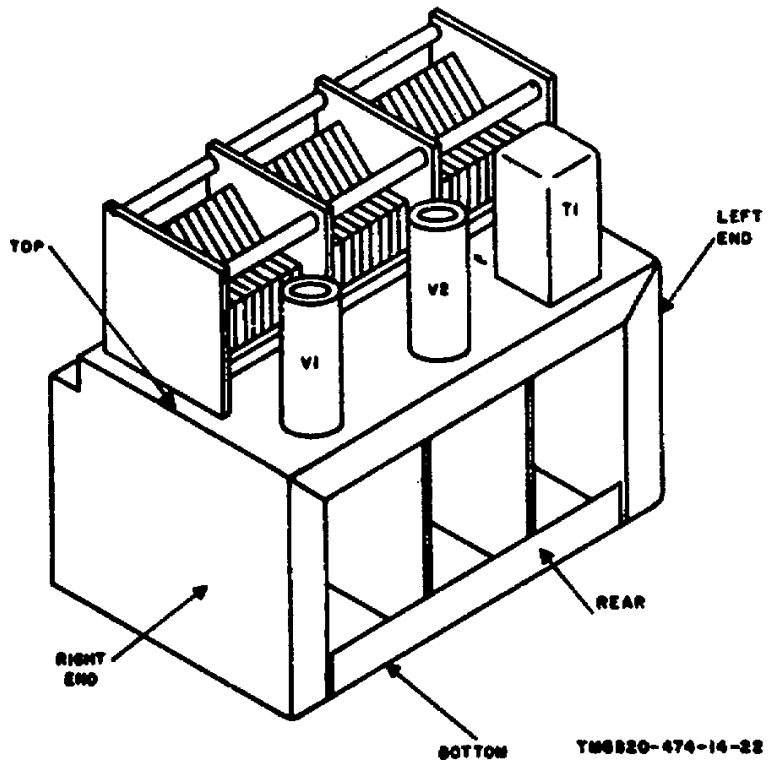

Figure 22. Receiver orientation of rf-if. Chassis.

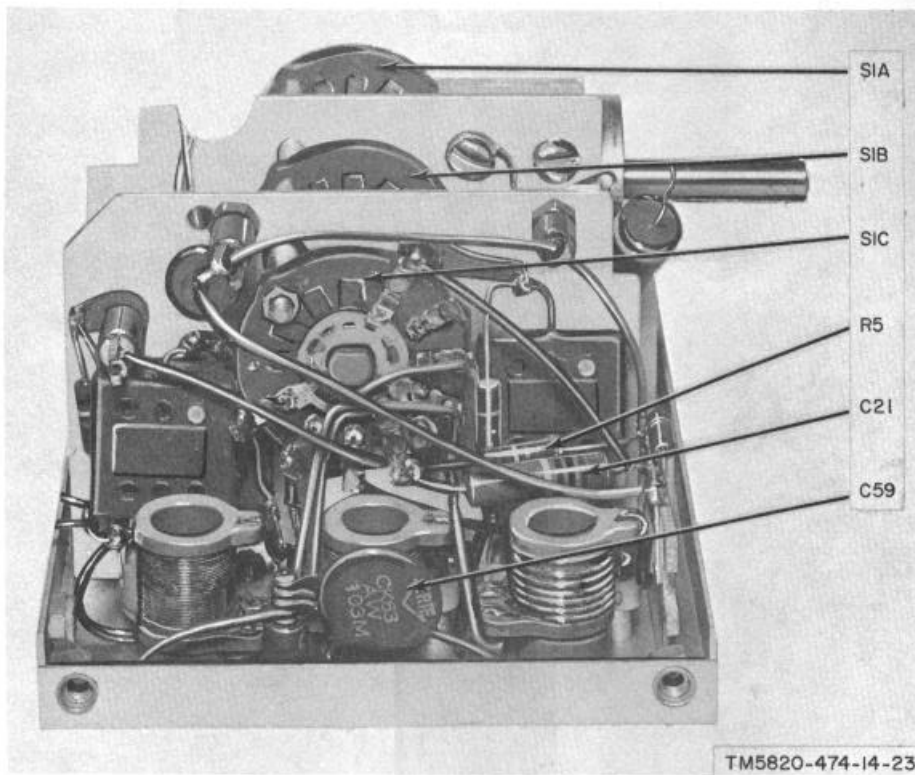

Figure 23. Receiver, left side of rf-if. chassis.

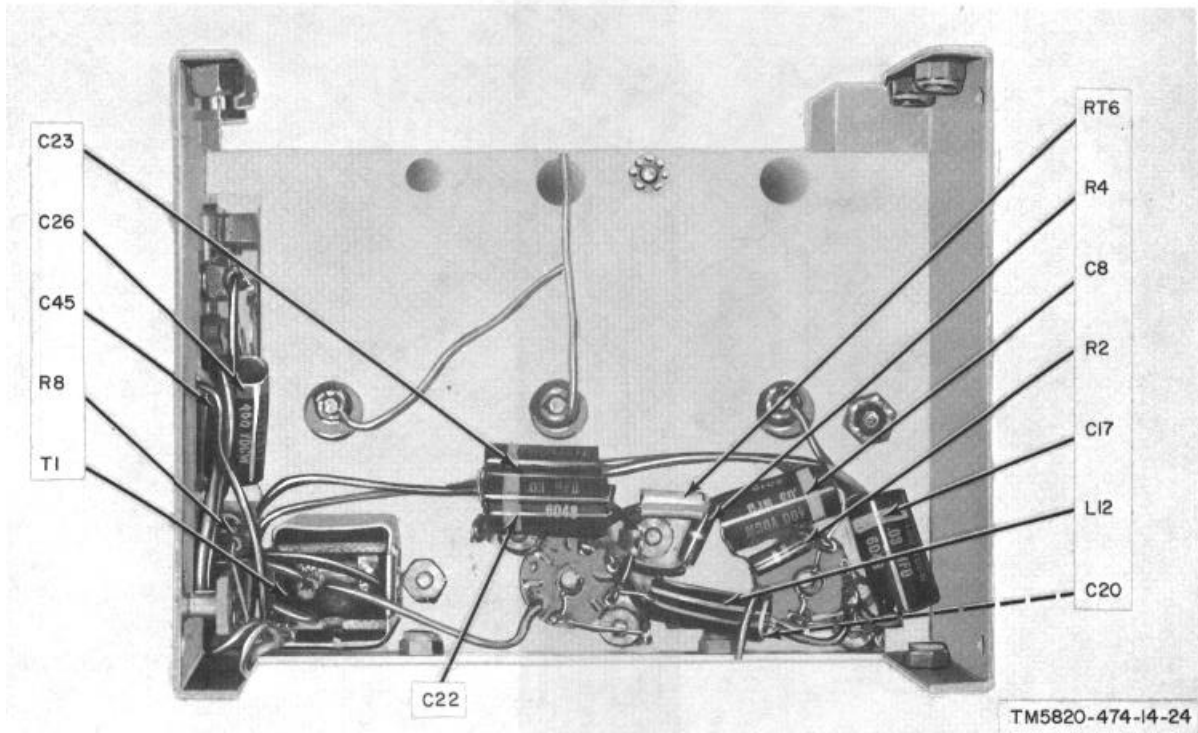

Figure 24. Receiver, top inside view of rf-if, chassis.

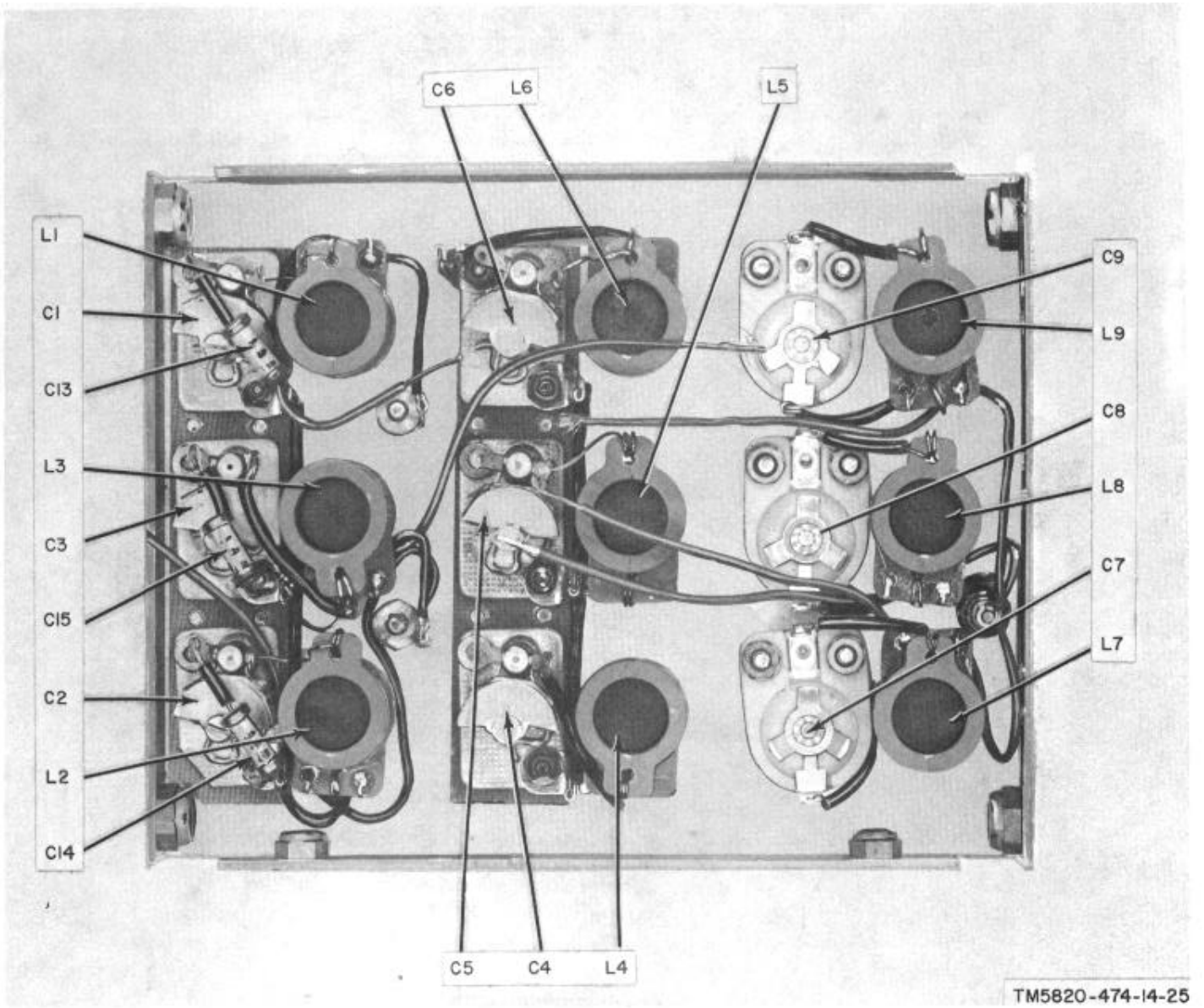

Figure 25. Receiver, bottom inside view of rf- if, chassis.

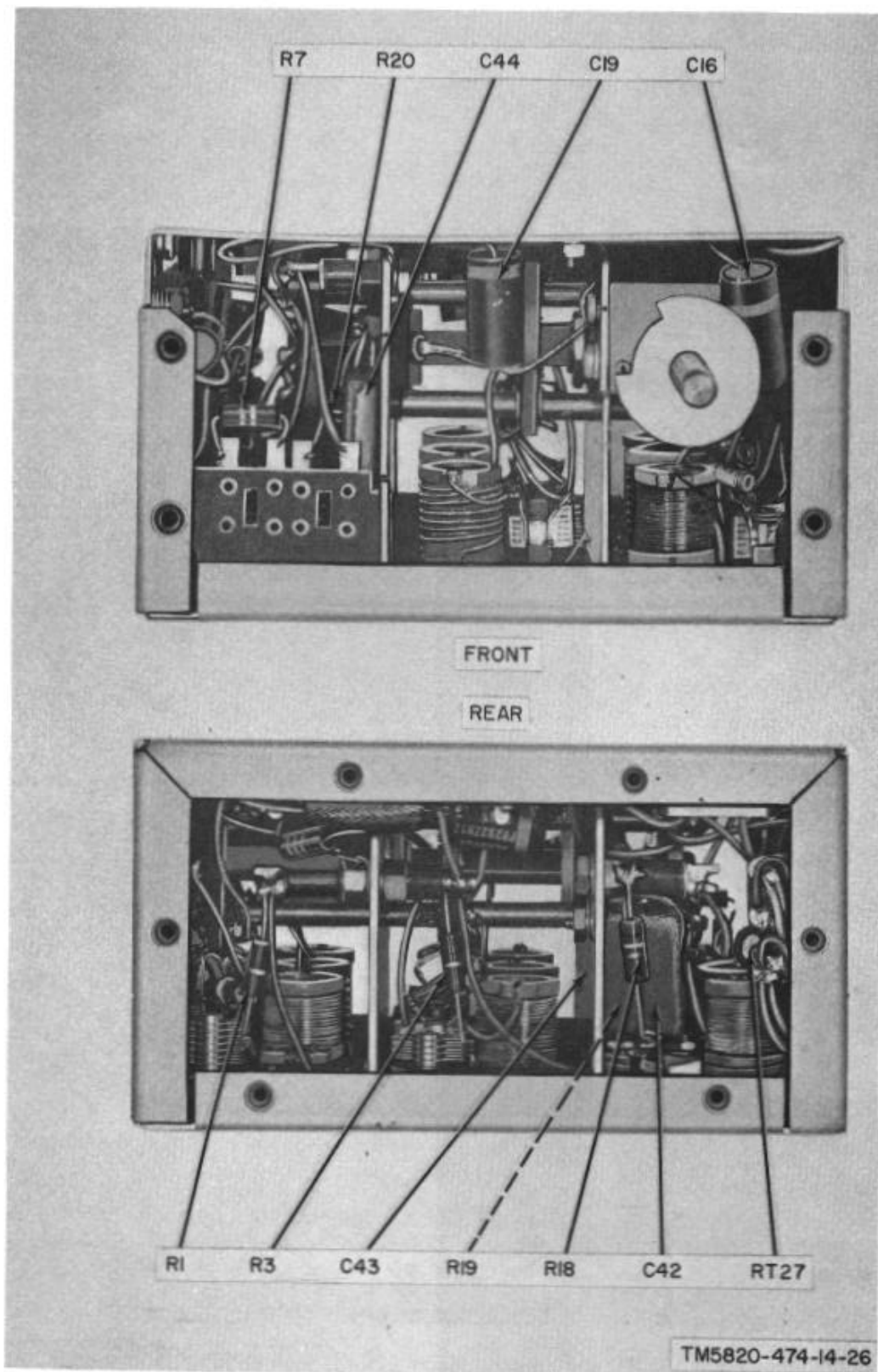
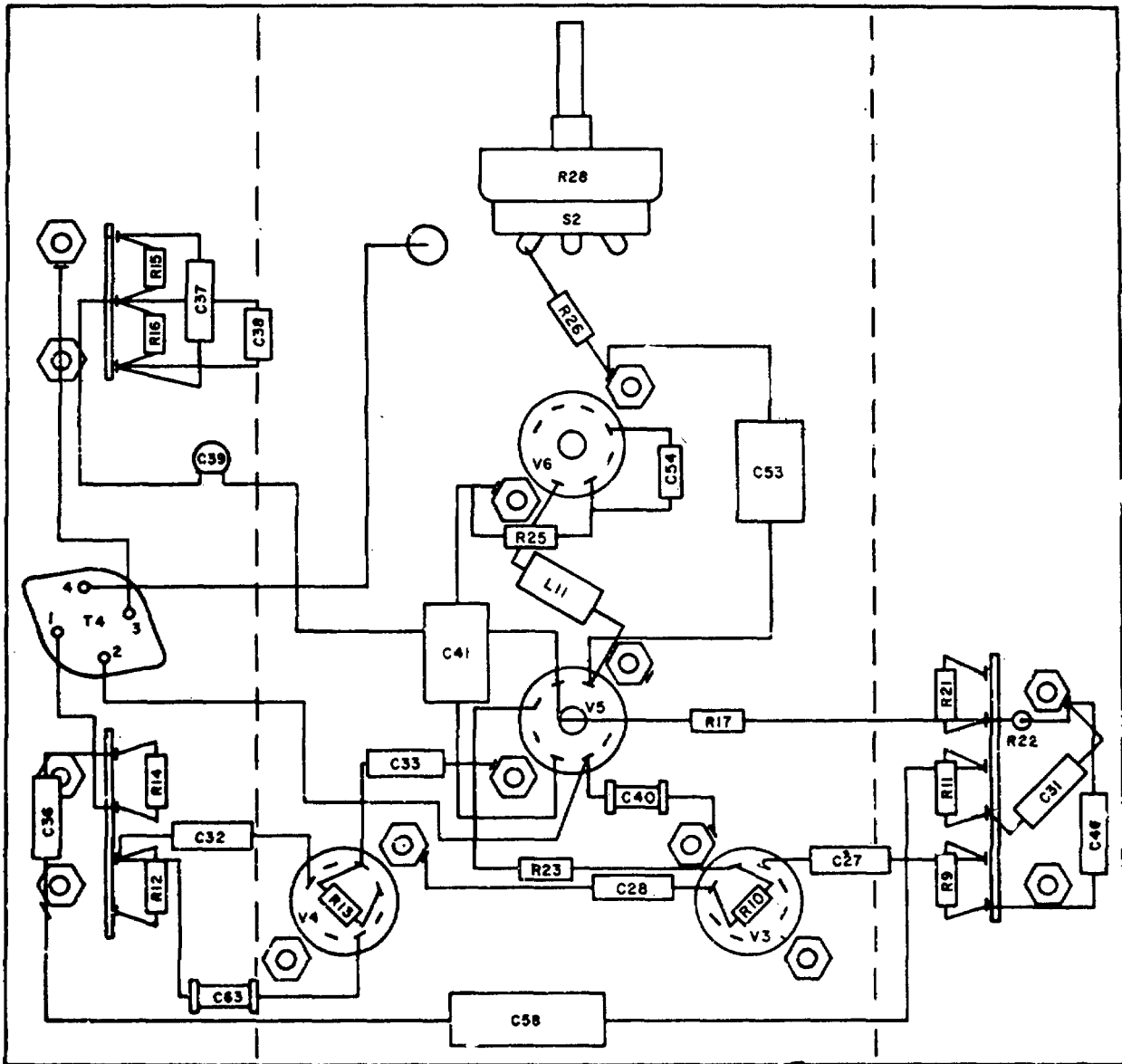

Figure 26. Receiver, front and rear views of rf-if, chassis.



TM 5820-474-14-27

Figure 27. Receiver if.-audio chassis.

67. Signal Substitution

a. General. The signal substitution procedures help to localize troubles to a stage of the receiver. An externally generated signal is substituted for the signal normally present in each stage. The test equipment required for the tests in b through d below is listed in paragraph 63. Ground one side of the rf signal generator or audio oscillator to the receiver chassis and connect the other side to the receiver test point

indicated. Because of the compactness of the receiver chassis, it is advisable to use a seven-pin test socket adapter for making connections to the test points. Apply the signals through a 0.01 uf capacitor.

b. Audiofrequency Tests. Connect the output of the audio oscillator to the points indicated. The headset will serve as an indication of receiver volume.

- (1) Set the audio oscillator for a 400-cycle output.

- (2) Connect the headset to PHONES jacks J3 and J4.
- (3) Apply the audio signal to pin 2 (plate) of V5 (fig. 27). Listen for a signal in the headset. If no signal is heard, check transformer T4 and capacitors C40 (fig. 27) and C57 (fig. 19).
- (4) Apply the audio signal to pin 6 (grid) of V5. If no increase in output is obtained in the headset, check V5 and the associated circuit components.
- (5) Apply the audio signal to the junction of resistor R15 and capacitor C39 (fig. 27). If the signal is not heard at the same volume as in the procedure given in (4) above, check C39 (fig. 27).

c. Intermediate-Frequency Tests. Start the tests at the output of the second if. amplifier stage (V4) and work forward to the first if. amplifier stage (V3).

- (1) Set the rf signal generator for a modulated output at 455 kc.
- (2) Connect the headset to PHONES jacks J3 and J4.
- (3) Apply the signal to pin 2 (plate) of V4 (fig. 27). Listen for a modulated output. If no signal is heard, check if. transformer T3 and the associated circuit components on the secondary of the transformer.
- (4) Apply the if. signal to pin 6 (grid) of V4 (fig. 27). The output signal should increase. If no increase is obtained, check V4 and the associated circuit components.
- (5) Apply the if. signal to pin 2 (plate) of V3. Listen for a modulated output. If no signal is heard, check if transformer T2 and capacitors C31, C32, and C63.
- (6) Apply the if. signal to pin 6 (grid) of V3. If no increase in output signal is obtained, check V3 and the associated circuit components.
- (7) Apply the if. signal to pin 2 (plate) of V2. Listen for a modulated output. If no signal is heard, check if transformer T1, capacitors C26 (fig. 24) and C27, and resistor R9 (fig. 27).

d. Radiofrequency Tests. Start the rf tests at the signal grid of (pin 6) of the converter (V2) and work back to the antenna terminal.

- (1) Set the rf signal generator for a modulated output at 4 mc.
- (2) Tune the receiver to 4 me.
- (3) Connect the headset to PHONES jacks J3 and J4.
- (4) Apply the rf signal to pin 6. If no modulated output is heard, check V2 and the associated circuit components.
- (5) Apply the rf signal to pin 2 (plate) of V1. Listen for a modulated output. If no output is heard, check capacitor C20 (fig. 24), coil L4 (fig. 25), and the contacts of switch S1B front and rear (fig. 23).
- (6) Apply the rf signal to pin 6 (grid) of V1. If no increase in the signal is obtained, check V1 and the associated circuit components.
- (7) Apply the rf signal to ANT jack J1. If no modulated output is heard, check antenna coil L1, capacitors C1 and C3 (fig. 25), and the contacts of S1A front and rear (fig. 23).

68. Isolating Trouble Within A Stage

When trouble has been localized to a stage, either through operational checks or signal substitution (para 67), use the techniques in a through d below to isolate the defective part.

a. Test the suspected tube in a tube tester or by substituting a tube known to be good.

b. Make voltage measurements at the tube sockets (fig. 28) and other points related to the stage in question. Use a seven-pin test socket adapter when making tube socket measurements.

c. If voltage readings are abnormal, make resistance measurements (fig. 28) to isolate open and short circuits. Refer also to the resistances of transformers and coils (para 69).

d. If signals are weak, and all checks fail to indicate a defective part, check the alignment of the receiver (para 89 through 92).

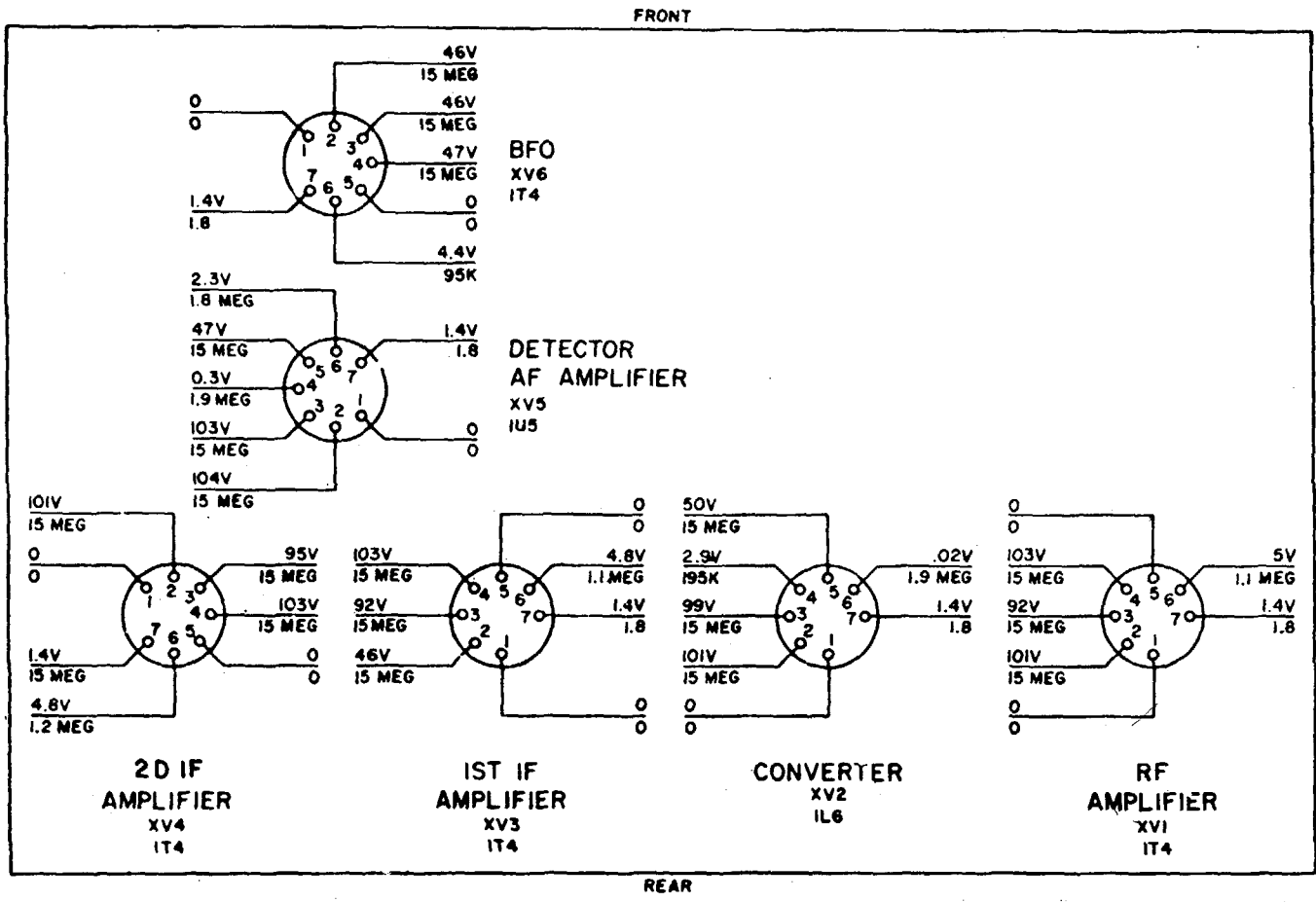

- NOTES:**
1. RECEIVER OPERATED FROM PP-2684/GRC-109 WITH 117 VAC INPUT FOR VOLTAGE MEASUREMENTS.
 2. **GAIN** CONTROL SET AT 2/3 MAXIMUM.
 3. **BEAT OSC** IN **OFF** POSITION.
 4. **RANGE** SET AT BAND 1.
 5. MEASUREMENTS MADE WITH VTVM, ELECTRONIC MULTIMETER TS-505/U OR EQUIVALENT.
 6. VOLTAGES AND RESISTANCES MEASURED TO CHASSIS GROUND.
 7. ALL SOCKETS VIEWED FROM BOTTOM.

TM5820-474-14-28

Figure 28. Receiver tube socket voltage and resistance diagram.

69. Resistance of Transformers and Coils

The resistances of transformer windings and coils in the receiver are listed in the table below.

| Transformer or coils | Terminals | Resistance (ohm) |
|----------------------|-----------|------------------|
| L1 | Primary | Less than 1 |
| | Secondary | Less than 1 |
| L2 | Primary | Less than 1 |
| | Secondary | Less than 1 |
| L3 | Primary | Less than 1 |
| | Secondary | Less than 1 |
| L4 | | Less than 1 |
| | | Less than 1 |
| L5 | | Less than 1 |
| | | Less than 1 |
| L6 | Primary | Less than 1 |
| | Secondary | Less than 1 |
| L7 | Primary | Less than 1 |
| | | Less than 1 |

| Transformer or coils | Terminals | Resistance (ohm) |
|----------------------|-------------|------------------|
| L8 | Secondary | Less than 1 |
| | Primary | Less than 1 |
| L9 | Secondary | Less than 1 |
| | Primary | Less than 1 |
| L10 | 1-2 | 9.6 |
| | 2-3 | 3.6 |
| L11 | | Less than 1 |
| L12 | | Less than 1 |
| T1 | Blue-red | 10 |
| | Green-black | 9 |
| T2 | Blue-red | 9 |
| | Green-black | 9.5 |
| T3 | Blue-red | 13 |
| | Green-black | 9 |
| T4 | 1-2 | 3,400 |
| | 3-4 | 115 |

Section III. TROUBLESHOOTING RADIO TRANSMITTER T-784/GRC-109

70. Reference Designation Changes

Differences exist between chassis stenciling for some transmitter parts and their designation on the schematic diagram (fig. 64). The following chart gives the conversion from chassis marking to schematic designation:

| Chassis marking | Schematic designation |
|-----------------|-----------------------|
| LMP- 1 | DS3 |
| N-1 | DS1 |
| N-2 | DS2 |
| RFC- 1 | L5 |
| RFC-2 | L7 |
| RFC-3 | L9 |
| RFC-4 | L6 |
| SW-1 | S1- |
| SW-2 | S3 |

71. Checking B+ Circuit for Shorts

a. *When to Check.* When either of the following conditions applies, check for short circuits and clear the trouble before applying power.

- (1) When the transmitter is serviced apart from other components of the radio set and the nature of the abnormal symptoms is not known.
- (2) When symptoms reported from operational tests indicate the possibility of a short circuit in B+ circuits.

b. *Measurement.* Make resistance measurements between pin 1 and pin 3 at power cable plug P1. An infinite resistance indication should be obtained. If an

abnormal reading is obtained, remove the transmitter from its case and make additional isolating checks to locate the faulty part. Correct the trouble before applying power.

72. Test Setup (fig. 29)

a. Bench tests of the transmitter require connection to a power source and to various test equipments. The power source must be connected to the transmitter for all dynamic-servicing procedures; the test equipment connections vary from test to test.

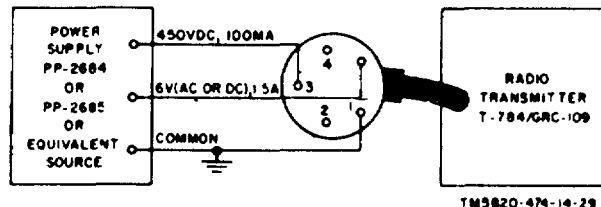

Figure 29. Test setup for troubleshooting transmitter.

b. Either the large or small power supply is the most convenient power source for use in bench testing. If either power supply is available, connect power plug P1 of the transmitter to the TRANS PWR jack on the power supply. If neither power supply is available, use an equivalent power source capable of supplying 6 volts at 1.5 amp, ac or dc and 450 volts at 100 ma dc.

73. Localizing Troubles

a. *General.* Procedures are outlined in the chart in d below for localizing troubles to the oscillator and power amplifier stages. Part locations are shown in figures 30 through 34. One or more of the localizing procedures may be necessary, depending on the symptoms. When the trouble has been localized to a stage, use the techniques outlined in paragraph 74 to isolate the faulty part.

b. *Use of Chart.* The troubleshooting chart supplements the operational checks detailed in the

operational checklist (para 33). If previous operational checks have resulted in a symptom listed in this chart, go directly to the symptom.

Caution: If operational symptoms are not known, or they indicate the possibility of short circuits, make the short-circuit checks (para 71) before applying power to the transmitter.

c. *Conditions for Tests.* All checks outlined in the chart are to be conducted with the transmitter connected to a power source (para 72).

d. *Troubleshooting Chart.*

| Item | Symptom | Possible trouble | Procedure |
|------|--|--|--|
| 1 | No output, no indication on any tuning lamp. | Open B+ circuit Open V1 and V2 cathode circuits.... Defective oscillator stage | Make resistance and continuity checks on B+ circuits. Clean contacts of telegraph key. Check L7 (fig. 34). Check V1. Make voltage and resistance measurements on V1 (fig. 35). |
| 2 | No output, no indication on antenna tuning lamp. Power amplifier and oscillator tuning normal. | Defective antenna tuning circuit..... | Check C14 (fig. 33), C15, S1, R13, and DS3 (fig. 30). Check wiring of antenna tuning circuit for shorts. |
| 3 | No output, no indication on power amplifier tuning lamp. Exciter tuning normal. | Defective power amplifier stage..... | Check V2. Make voltage and resistance measurements on V2 (fig. 35). |
| 4 | Transmitter on continuously; key has no effect. | Shorted key click filter | Check C5. |
| 5 | Transmitter tunes properly, but has low output on high frequencies. | Low output from oscillator | Check V1. Make voltage and resistance measurements on V1 (fig. 35). Check crystal by substitution. |
| 6 | Transmitter keying chirpy or sluggish. | Oscillator not properly tuned | Check adjustment of C6 (fig. 31). Check V1. Check crystal by substitution. |
| 7 | Transmitter unstable. present with crystal removed. | Output Power amplifier oscillating .. | Check C10 (fig. 32), C11 (fig. 33), L8, and R12 (fig. 30). |
| 8 | Antenna "hot" with key up | Shorted blocking capacitor | Check C13. |

74. Isolating Trouble Within Stage

When trouble has been localized to a stage, use the techniques in a through c below to isolate the defective part.

a. Test the suspected tube in a tube tester or by substituting a tube known to be good.

b. Make voltage measurements at the tube sockets (fig. 35) and other points related to the stage in question.

c. If voltage indications are abnormal, make resistance measurements (fig. 35) to isolate open and short circuits. Refer also to the resistances of coils and chokes listed in paragraph 75.

75. Resistance of Coils and Chokes

The resistances of coils and chokes in the transmitter are listed in the chart below.

| Coil or choke | Resistance (ohm) |
|---------------|------------------|
| L1 | Less than 1 |
| L2 | Less than 1 |
| L3 | Less than 1 |
| L4 | Less than 1 |
| L5 | 22 |
| L6 | 22 |
| L7 | 22 |
| L8 | 22 |
| L9 | 40 |

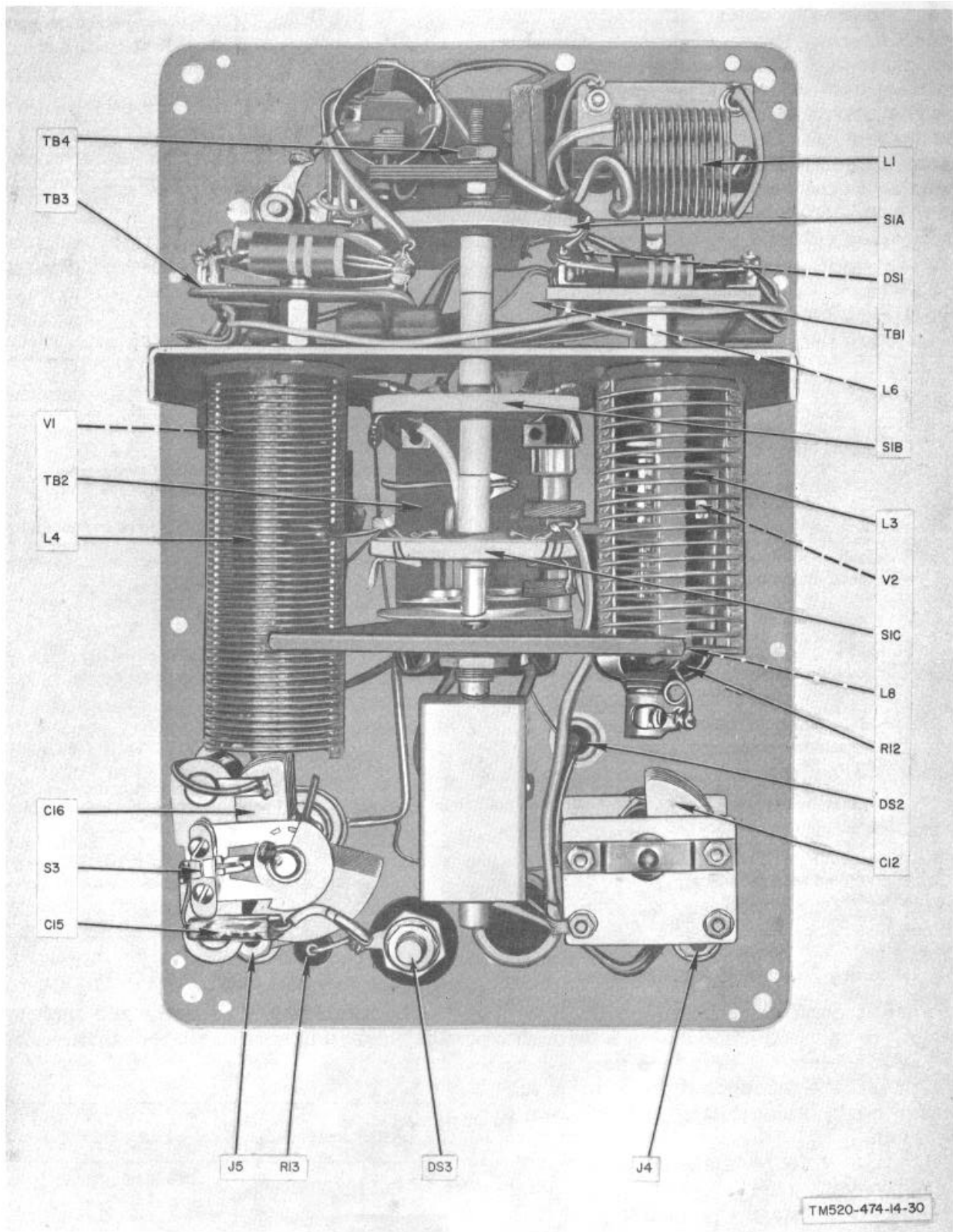

Figure 30. Transmitter, rear view.

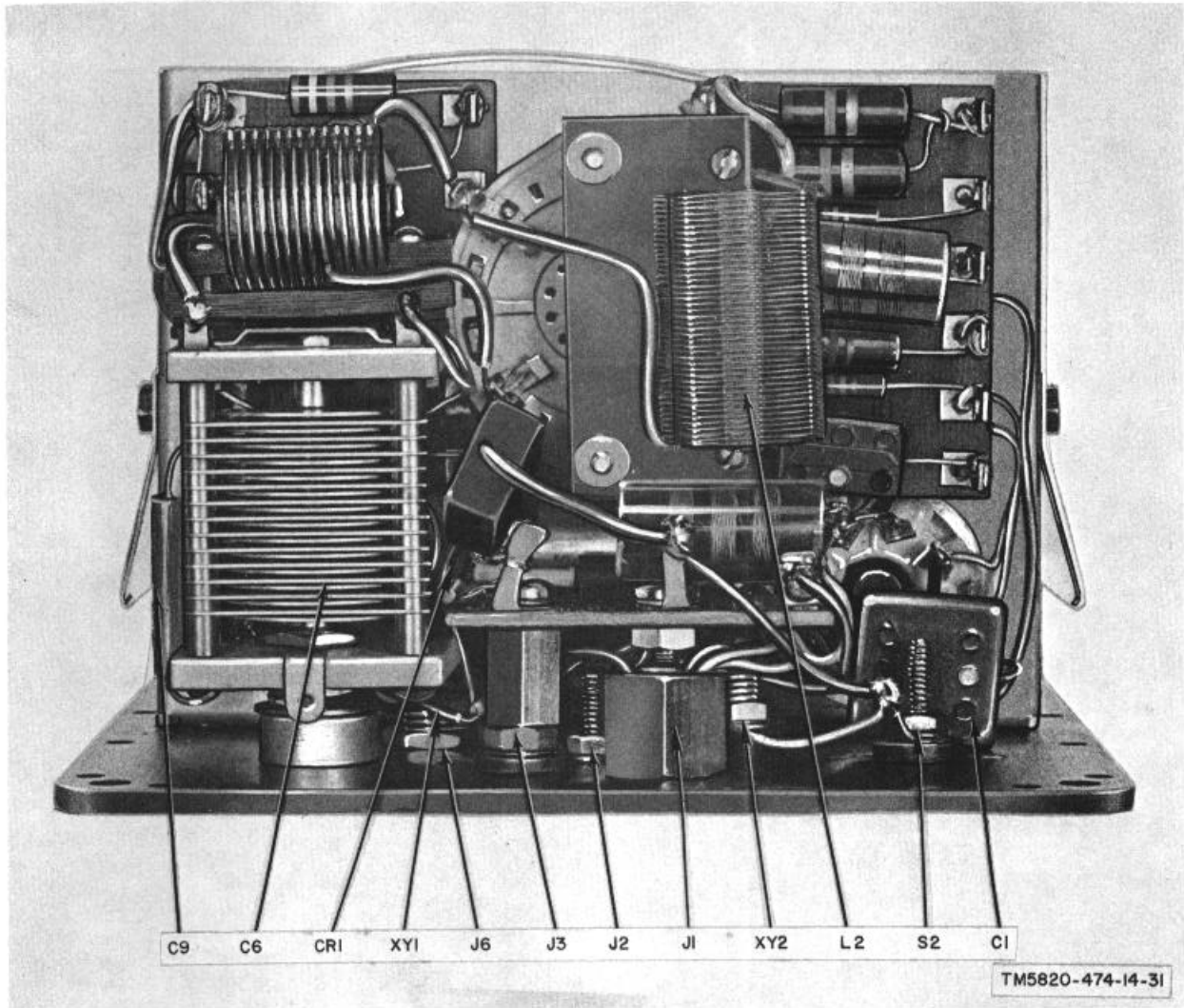

Figure 31. Transmitter, right side view.

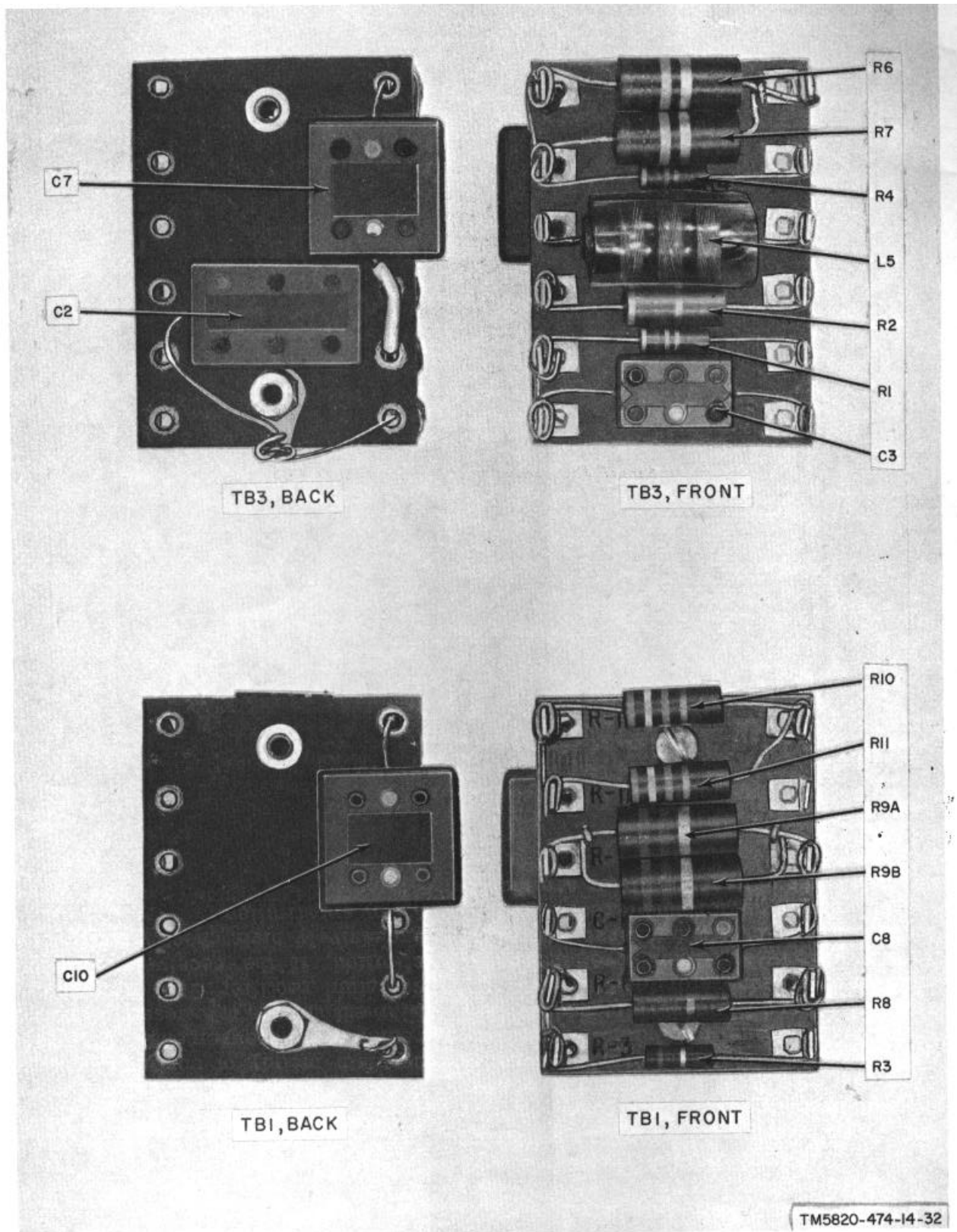

Figure 32. Transmitter terminal boards TB1 and TB3.

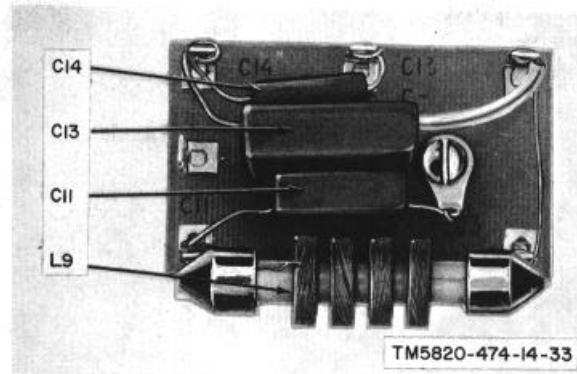

Figure 33. Transmitter terminal board TB2.

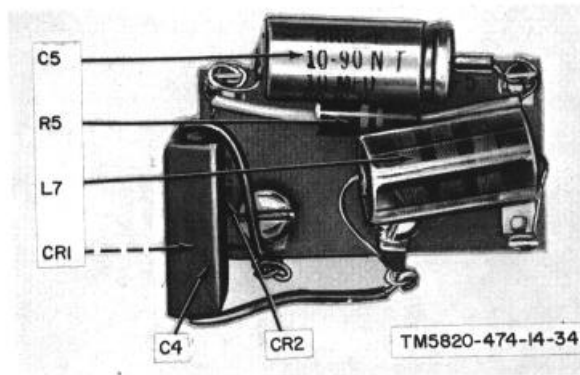
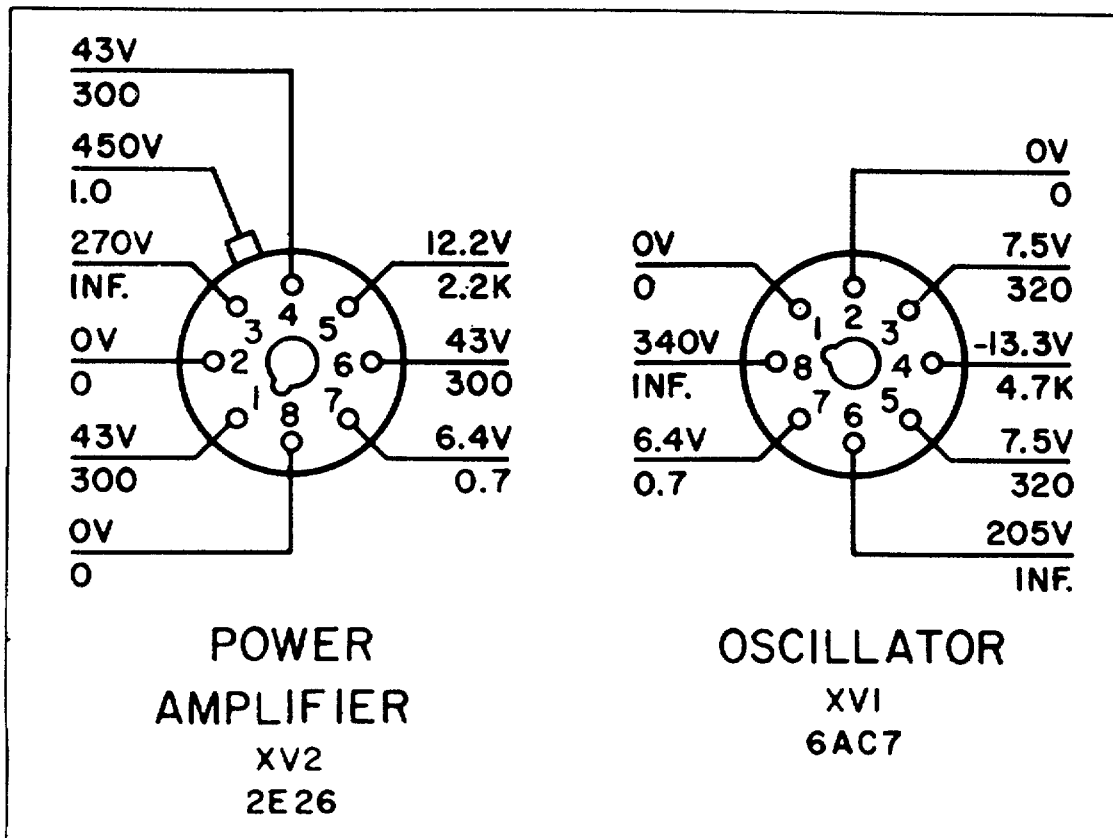

Figure 34. Transmitter terminal board TB4.

REAR



FRONT

NOTES:

1. TRANSMITTER OPERATED INTO 72-OHM DUMMY LOAD FROM PP-2684/GRC-109 WITH 117 VAC INPUT FOR VOLTAGE MEASUREMENTS.
2. MEASUREMENTS MADE WITH VTVM, ELECTRONIC MULTIMETER TS-505/U OR EQUIVALENT.
3. VOLTAGES AND RESISTANCES MEASURED TO CHASSIS GROUND.
4. ALL MEASUREMENTS MADE WITH KEY DOWN.
5. ALL SOCKETS VIEWED FROM BOTTOM.

TM5820-474-14-35

Figure 35. Transmitter tube socket voltage and resistance diagram.

Section IV. TROUBLESHOOTING POWER SUPPLY PP-2684/GRC-109

76. Reference Designation Changes

Differences exist between chassis stenciling for some large power supply parts and their designation on the schematic diagram (fig. 65). The following chart gives the conversion from chassis marking to schematic designation.

| Chassis marking | Schematic designation |
|-----------------|-----------------------|
| SS-1 | CR1 |
| SS-2 | CR2 |
| SS-3 | CR3 |
| SS-4 | CR4 |
| SS-5 | CR5 |
| SS-6 | CR6 |
| SS-7 | CR7 |
| SW-1 | S1 |
| SW-2 | S2 |

77. Checking Transmitter, Filament and B+ Circuits for Shorts

a. When to Check. When either of the following conditions applies, check for short circuits and clear the trouble before applying power.

- (1) The nature of the abnormal symptoms is not known.
- (2) Symptoms reported from operational tests indicate the possibility of a short circuit in the large power supply.

b. Measurements. Make the resistance measurements indicated in the chart below.

If abnormal results are obtained, remove the power supply from its case and make the additional isolating checks outlined. When the faulty part is found, correct the trouble before applying power to the unit.

| Points of measurement | Short circuit tests Normal resistance | Isolating procedure |
|--|--|---|
| Between pins 1 and 3 of RCVR PWR. jack. | Approximately 300K | If resistance is zero, check C7B (fig. 36) for short, or for short-circuited B, wiring. If resistance is low, check C7B for leakage; check C7A, C6 (fig. 38), and C10 for shorts and/or leakage. |
| Between pins 1 and 4 of RCVR PWR. jack. | Approximately 90 ohms.... | If resistance is zero, check C8 and C9 for short, or for short-circuited filament wiring. If resistance is low, check C8 and C9 (fig. 36) for leakage. |
| Between pins 1 and 3 of TRANS PWR. jack. | Approximately 110K | If resistance is low, check C4A, C4B, C5A, and C5B for short, or for short-circuited B wiring. If resistance is low, check C4A, C4B, C5A, and C5B (fig. 36) for leakage. |

78. Test Setup

a. General. Complete bench tests of the large power supply require connection to three different power sources: 75 to 260 volts ac, 40 to 400 cycles; 6 volts dc at 12.5 amperes; and the handcranked generator. The large power supply must be connected to a power source for all dynamic-servicing procedures. It must also be connected to various test equipment for bench tests. Test equipment connections vary from test to test.

b. Alternate Power Sources. Power required for checking the large power supply is normally supplied by ac lines and the 6 volts dc from a storage battery. A 6-volt battery eliminator with good regulation can be used in place of the storage battery. The hand-cranked generator can be replaced by a power supply with an output of 450 volts dc at 115 ma, and 6 volts dc at 2.5 amperes.

79. Localizing Troubles

a. *General.* Procedures are outlined in the chart in d below for localizing troubles to the rectifier, filter, regulator, and vibrator circuits of the large power supply. Part locations are shown in figures 36 through 39. One or more of the localizing procedures may be necessary, depending on the nature of the operational symptoms. When the trouble has been localized to a particular circuit, make voltage and resistance measurements to isolate the trouble to a particular part.

b. *Use of Chart.* The troubleshooting chart supplements the operational checks detailed in the operational checklist (para 33). If previous operational checks have resulted in a symptom listed in this chart, go directly to the symptom.

Caution

If operational symptoms are not known, or they indicate the possibility of short circuits, make the short-circuit checks (para 77) before applying power.

c. *Conditions for Tests.* All checks outlined in the chart are to be conducted with the large power supply connected to a power source (para 78).

d. Troubleshooting Chart.

| Item | Symptom | Possible trouble | Procedure |
|------|--|--|---|
| 1 | No output voltage for receiver or transmitter during operation from ac lines. No indication on ac voltmeter. | Fuse blown Shorted hash filters | Check fuse F2 (fig. 37). Check C6, C12 and C13 (fig. 33). |
| 2 | No output voltage for receiver or transmitter during operation from ac lines. Ac voltmeter reading normal. | Defective power transformer Defective power selector switch. | Check the two ac primary windings of T1 (fig. 40). Check S2E, S2F, and S2G (fig. 36). |
| 3 | No output voltages for transmitter or receiver during operation from storage battery. | Fuse blown Shorted hash filter | Check fuse F1 (fig. 37). Check C14 (fig. 37). |
| 4 | No B+ voltages for transmitter or receiver during operation from ac lines. Filament voltages normal. | Defective power transformer Defective bridge rectifier Shorted buffer capacitor | Check high voltage secondary winding of T1. Check CR1, C2., CR3, and CR4 (fig. 36) by substitution. Check C3 (fig. 36) for short. |
| 5 | No B+ voltage for transmitter or receiver during operation from storage battery. Filament voltages normal. | Defective vibrator G1 Shorted hash filter capacitors Shorted buffer capacitor Defective power transformer | Check vibrator (fig. 36) by substitution. Check C1, C2 (fig. 39), and C6 (fig. 38) Check C3 (fig. 36). Check vibrator winding on primary |
| 6 | No B+ voltage for transmitter or receiver when operated from hand-cranked generator. Filament voltages normal. | Defective switches Shorted hash filter | of T1 (fig. 36). Check C6 (fig. 38). |
| 7 | No transmitter B+ during operation from ac lines or storage battery. All other voltages normal. | Open rf choke Defective rectifier | Check L1 (fig. 36). Check CR2 and CR4 (fig. 36) by substitution. |
| 8 | No transmitter B+ during operation from hand-cranked generator. All other voltages normal. | Open rf chokes Defective CHARGE-OPERATE switch. | Check L1 (fig. 36) and L3 (fig. 38). Check S1B (fig. 36). |
| 9 | No receiver B+, during operation from ac lines or storage battery. All other voltages normal. | Open receiver B+ filter circuit. | Check L3, L5, R5, R6, and R7 (fig. 38). |
| 10 | No receiver B+, during operation from hand-cranked generator. All other voltages normal. | Open in receiver B+ filter circuit. | Check R5, R6, R7, and L5. |

| Item | Symptom | Possible trouble | Procedure |
|------|---|--|---|
| 11 | No transmitter filament voltage during operation from ac lines. All other voltages normal. | Defective power transformer Defective power selector switch. | Check 6.3-volt secondary winding of T1 (fig. 36). Check S1D. |
| 12 | No transmitter filament voltage during operation from storage battery or hand-cranked generator. All other voltages normal. | Defective power selector switch. | Check S1D (fig. 36). |
| 13 | No receiver filament voltage during operation from ac line. All other voltages normal. | Defective receiver filament winding. Defective filament rectifiers | Check winding on T2 (fig. 36). Check CR5 and CR6 (fig. 36) by substitution. |
| 14 | No receiver filament voltage during operation from storage battery or hand-cranked generator. All other voltages normal. | Open voltage-dropping resistors. Open filter choke Defective switches Open voltage-dropping resistor Open filter choke Defective power selector switch. | Check R3 and R4 (fig. 38). Check L2 (fig. 36). Check S1A and S2C. Check R4 (fig. 38). Check L2 (fig. 36). Check S2C. |
| 15 | No 6-volt output for battery charging; all other modes of operation normal. | Blown fuse Defective CHARGE-OPERATE switch. Open current-limiting resistor | Check F1. Check S1 (fig. 36). Check R10. |
| 16 | Receiver B+ voltage abnormally high. All other voltages normal. | Defective voltage-regulator tube. | Check V1 by substitution. |
| 17 | Receiver filament voltage abnormally high. All other voltages normal. | Defective voltage-regulator diode. | Check CR7 (fig. 36) by substitution. |
| 18 | Excessive ripple on transmitter B+ voltage. | Defective transmitter B+ filter circuit. | Check C4A, C4B, C5A, and C5B (fig. 36). |
| 19 | Excessive ripple on receiver B+ voltage. | Defective receiver B+ filter circuit. | Check C7A and C7B (fig. 36) |
| 20 | Excessive hum on receiver filament voltage. | Defective receiver filter circuit. | Check C8 and C9 (fig. 36). |
| 21 | All voltages low during operation from storage battery. Excessive battery drain. | Defective vibrator Open buffer capacitor | Check vibrator G1 (fig. 36) by substitution. Check C3. |

80. Resistances of Transformer and Chokes

The resistances of chokes and power transformer windings are listed in the chart below:

| Transformer or choke | Across winding | Resistance (ohm) |
|----------------------|---------------------------|------------------|
| T1 (fig. 36) | Blk and blu-wht | Less than 1 |
| | Blu-wht and blk | Less than 1 |
| | Red and wht-blk | 65 |
| | Wht-tlk and yel-red | 67 |
| | Blk-yel and brn | 4.9 |
| | Br and blk-red | 1.0 |
| | Blk-red and blu | 1.4 |
| | | |

| Transformer or choke | Across winding | Resistance (ohm) |
|--|------------------------------|------------------|
| L1 (fig. 36) L2 (fig. 36) L3 (fig. 38) L4 (fig. 39) L5 (fig. 38) | Blu and blu-wht | 1.4 |
| | Wht and brn-wht | 5.3 |
| | Brn-wht and grn | 1.1 |
| | Grn and wht-red | 1.5 |
| | Wht-red and blk-wht | 1.5 |
| | Wht-org-red and yel | Less than 1 |
| | Yel and wht-red-blk | Less than 1 |
| | Wht-brn-yel and wht-blk-yel. | Less than 1 |
| | | 21 |
| | | 5.2 |
| | | 21 |
| | | Less than 1 |
| | | 21 |

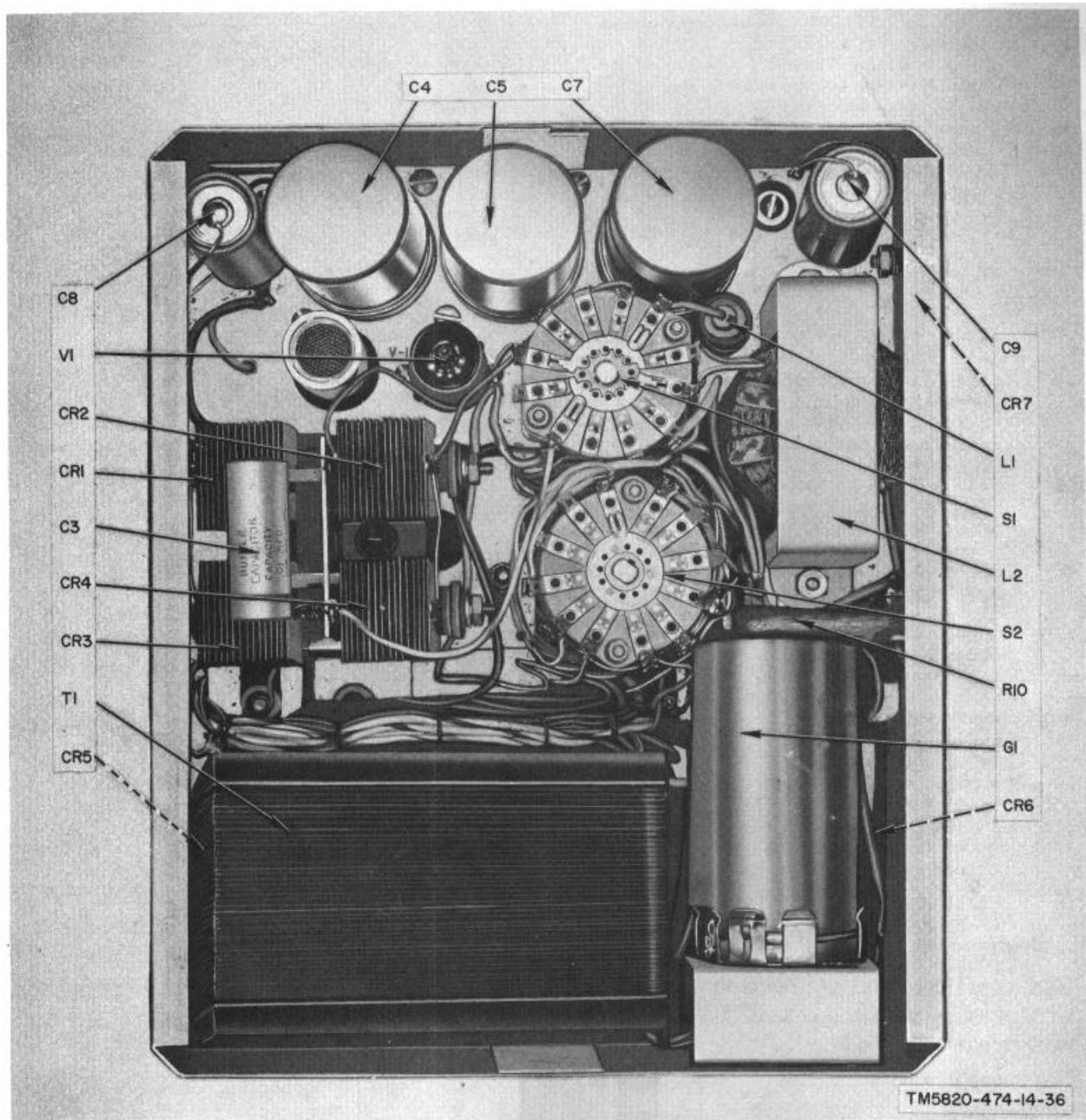

Figure 36. Large power supply, rear view.

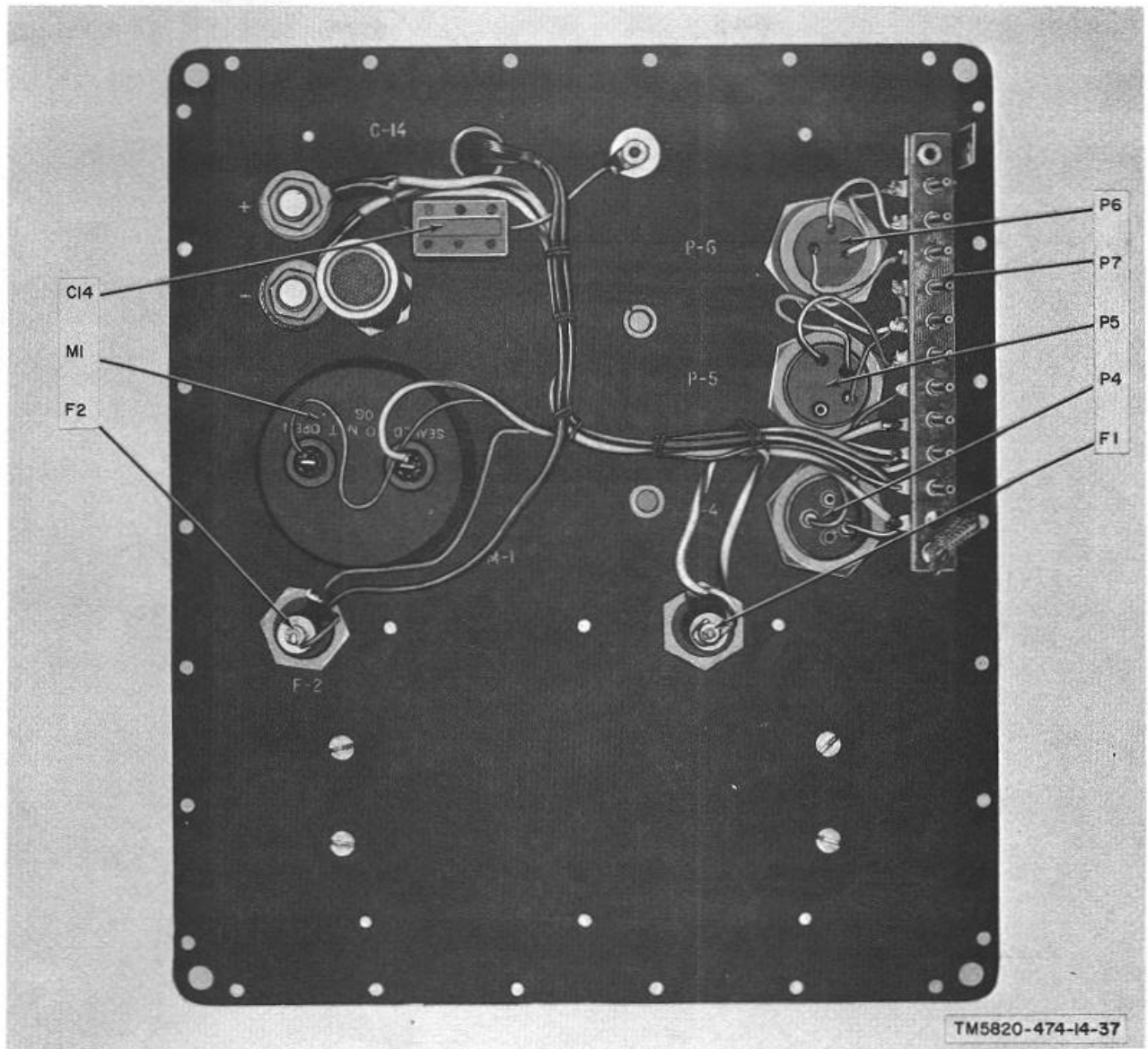

Figure 37. Large power supply, rear view of front panel.

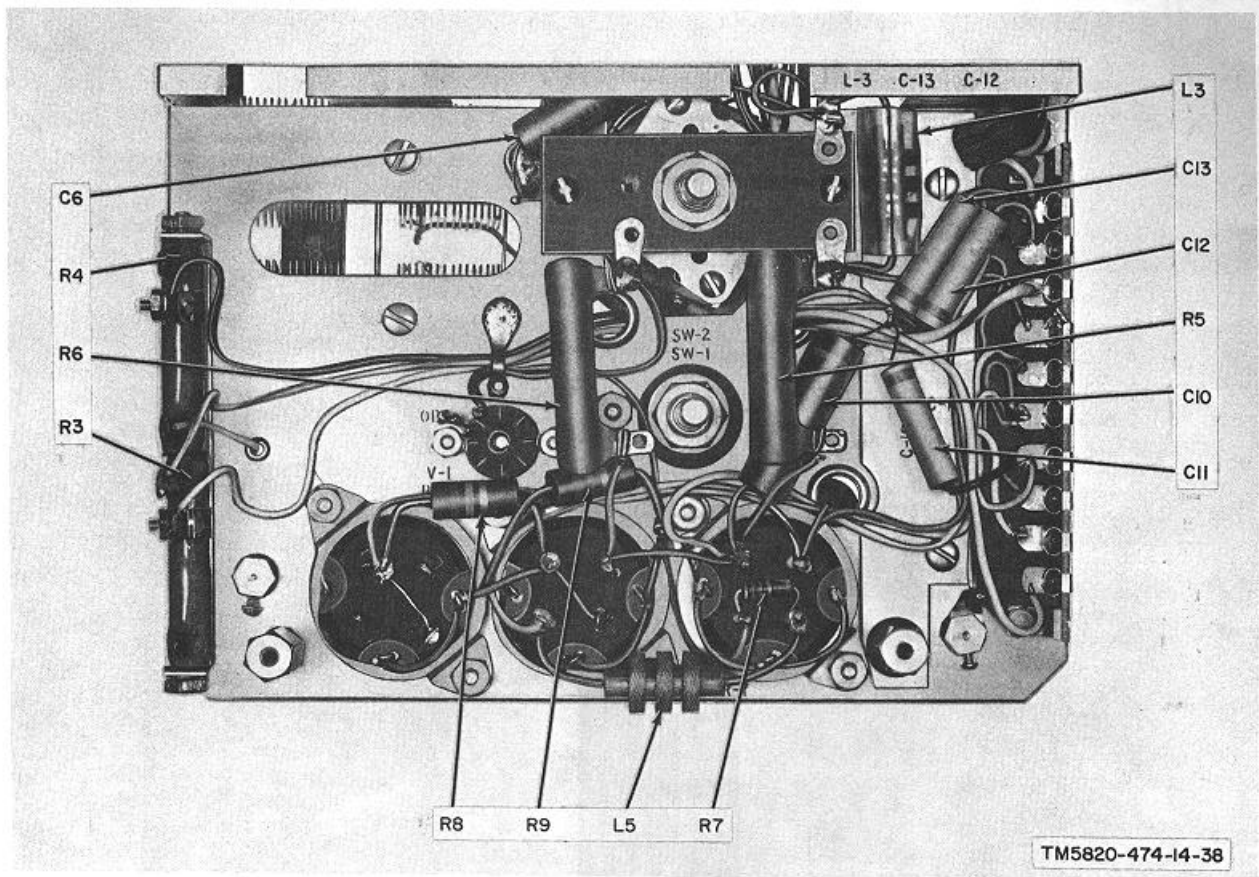

Figure 38. Large power supply, underside of chassis.

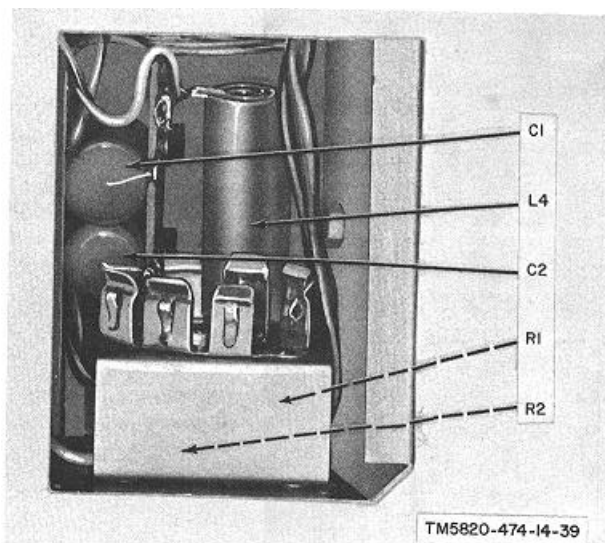

Figure 39. Large power supply, area behind vibrator.

Section V. TROUBLESHOOTING POWER SUPPLY PP-2685/GRC-109

81. Checking Filament and B+ Circuits for Shorts

a. When to Check. When either of the following conditions applies, check for short circuits and clear the troubles before applying power.

(1) The nature of the abnormal symptoms is not known.

(2) Abnormal symptoms reported from operational test indicate the possibility of short circuits.

b. Measurements. Make the resistance measurements indicated in the chart below. If abnormal results are obtained, remove the power supply from its case and make the, isolating checks outlined. When the faulty part is found, correct the trouble before applying power.

| Short-circuit tests | | |
|--|---------------------------------|---|
| Point of measurement | Normal resistance | Isolating procedure |
| Between pins 1 and 3 of RCVR PWR jack P2 (fig. 40). | Approximately 1.5 megohms | . If resistance is zero, check C2 (fig. 43) for short, or for short-circuited B+ wiring. If resistance is low, check C2 for leakage; check C1 for short. |
| Between pins 1 and 4 of RCVR PWR jack P2. | Approximately 150 ohms | If resistance is zero, check C3 and C4 (fig. 43) for short, or for short-circuited filament wiring. If resistance is low, check C3 and C4 for leakage. |
| Between pins 1 and 3 of TRANS PWR Jack P1 (fig. 40). | Approximately 10 megohms | If resistance is zero, check C5 (fig. 43) for short, or for short-circuited B+ wiring. If resistance is low, check C5 for leakage. |

82. Test Setup

Bench tests for the small power supply require connection to a power source of 75 to 260 volts ac, 40 to 400 cycles, and to various test equipments. The smallpower supply must be connected to a power source for all dynamic-servicing procedures. Test equipment connections vary from test to test.

b. Use of Chart. The troubleshooting chart supplements the operational checks detailed in the operational checklist (para 33). If previous operational checks have resulted in a symptom listed in this chart, go directly to the symptom.

Caution

If operational symptoms are not known, or they indicate the possibility of short circuits, make the short-circuit checks (para 81) before applying power.

83. Localizing Troubles

a. General. Procedures are outlined in the chart in d below for localizing troubles to the filter, and regulator circuits. Part locations are shown in figures 40 through 44. One or more of the localizing procedures may be necessary, depending on the nature of the operational symptoms. When the trouble has been localized to a particular circuit, make voltage and resistance measurements to isolate the trouble to a particular part.

c. Conditions for Tests. All checks outlined in the chart are to be conducted with the small power supply connected to a power source (para 82).

d. Troubleshooting Chart.

| Item | Symptom | Possible trouble | Procedures |
|------|---|------------------|--------------------------|
| 1 | No output voltage for receiver or transmitter. No indication on ac voltmeter. | Blown fuse..... | Check fuse F1 (fig. 40). |

| Item | Symptom | Possible trouble | Procedures |
|------|--|--|---|
| 2 | No output voltage for receiver or transmitter. Ac voltmeter indication normal. | Defective power transformer | Check primary windings of T1 (fig. 40). |
| 3 | No transmitter or receiver B+ Filament voltages normal. | Defective power selector switch Defective power transformer T1 (fig. 40). Defective bridge rectifier | Check S1. Check high voltage secondary of T1 (fig. 40). Check CR1, CR2, CR3, and CR4 (fig. 43) by substitution. |
| 4 | No transmitter B+. All other voltages normal. | Defective rectifier | Check CR2 and CR4 (fig. 43) by substitution. |
| 5 | No receiver B+. All other voltages normal. | Open in receiver B+ filter circuit | Check R2 (fig. 41) and R3 (fig. 43). |
| 6 | No transmitter filament voltage. All other voltages normal. | Defective power transformer of T1 (fig. 40). | Check 6.3-volt secondary winding |
| 7 | No receiver filament voltage. All other voltages normal. | Defective power transformer of T1 (fig. 40). Defective filament voltage rectifier. Open voltage-dropping resistor Open filter choke | Check receiver filament winding Check CR6 and CR7 (fig. 42) by substitution. Check R1 (fig. 41). Check L1 (fig. 44). |
| 8 | Receiver B+ abnormally high. All other voltages normal. | Defective voltage-regulator tube | Check V1 by substitution. |
| 9 | Receiver filament voltage abnormally high. All other voltages normal. | Defective voltage-regulator diode | Check CR5 (fig. 44) by substitution. |
| 10 | Excessive ripple on transmitter B+ voltage. | Defective filter capacitor | Check C5 (fig. 43). |
| 11 | Excessive ripple on receiver B+ voltage | Defective receiver B+ filter circuit | Check C1 and C2 (fig. 43). |
| 12 | Excessive ripple on receiver filament voltage. | Defective receiver B+ filter circuit | Check C3 and C4 (fig. 43). |

84. Resistances of Transformer and Choke

The resistances of the power transformer and filter choke are given in the chart below:

| Transformer or choke | Winding | Resistance (ohm) |
|----------------------|--------------------|------------------|
| L1 (fig. 44) | | 5.5 |
| T1 (fig. 40) | Red and blk | 55 |
| | Blk and red-yel .. | 55 |
| | Blk-yel and brn .. | 4.3 |

| Transformer or choke | Winding | Resistance (ohm) |
|----------------------|---------------------|------------------|
| | Brn and blk-red | 1.0 |
| | Blk-red and blu | 1.2 |
| | Blu and blu-wht | 1.2 |
| | Wht and grn-wht | 4.7 |
| | Grn-wht and grn | 1.0 |
| | Grn-and red-wht | 1.3 |
| | Red-wht and blk-wht | 1.3 |
| | Orn-red and yel | Less than 1 |
| | Yel and blu | Less than 1 |
| | Blu and blk-yel | Less than 1 |

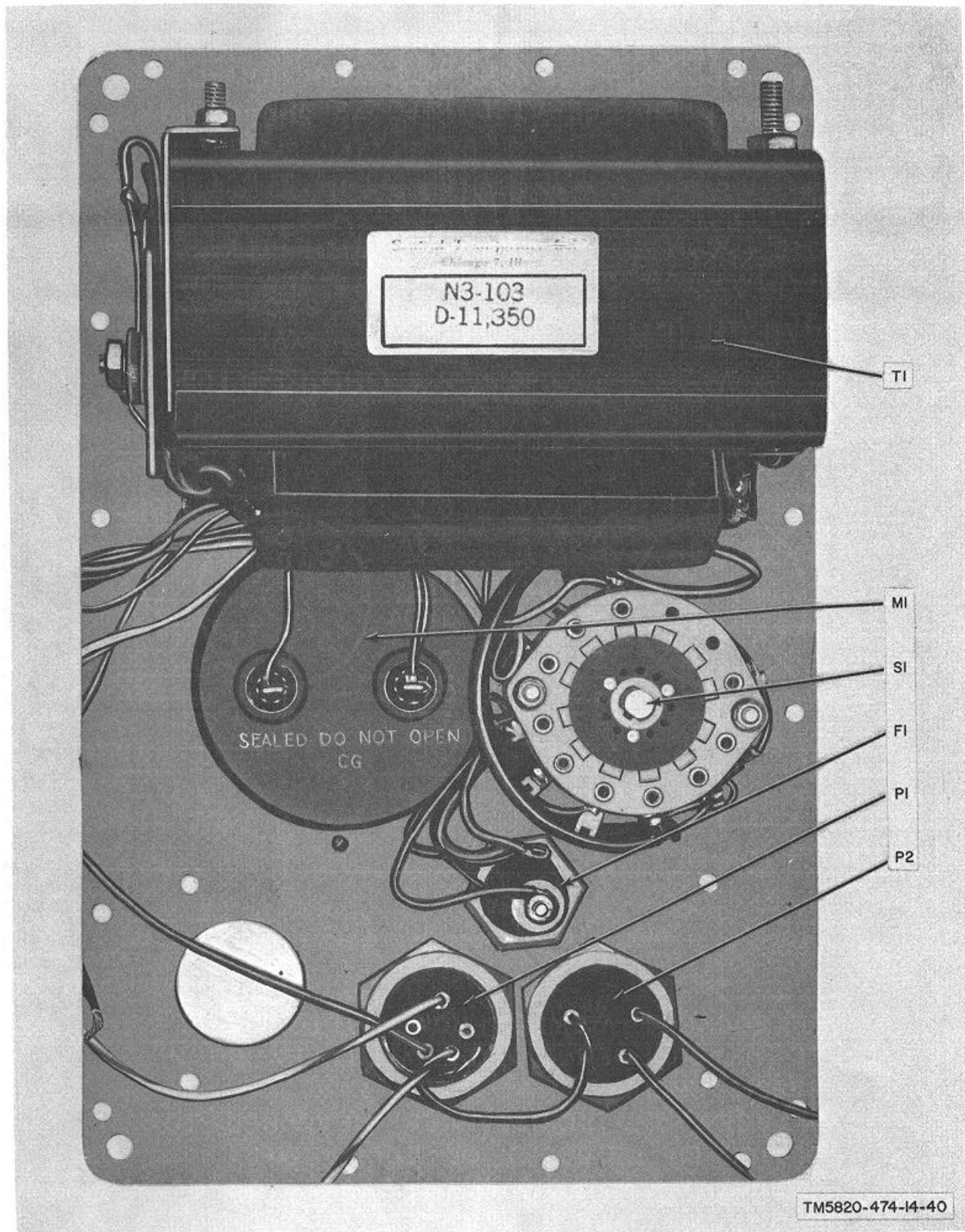

Figure 40. Small power supply, rear view of front panel.

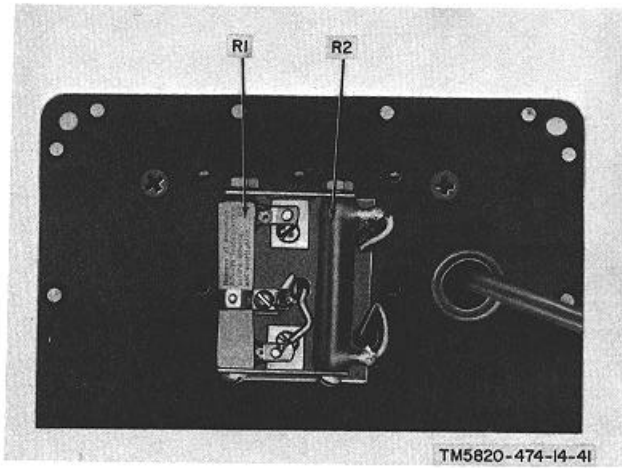

Figure 41. Small power supply, resistor cover removed.

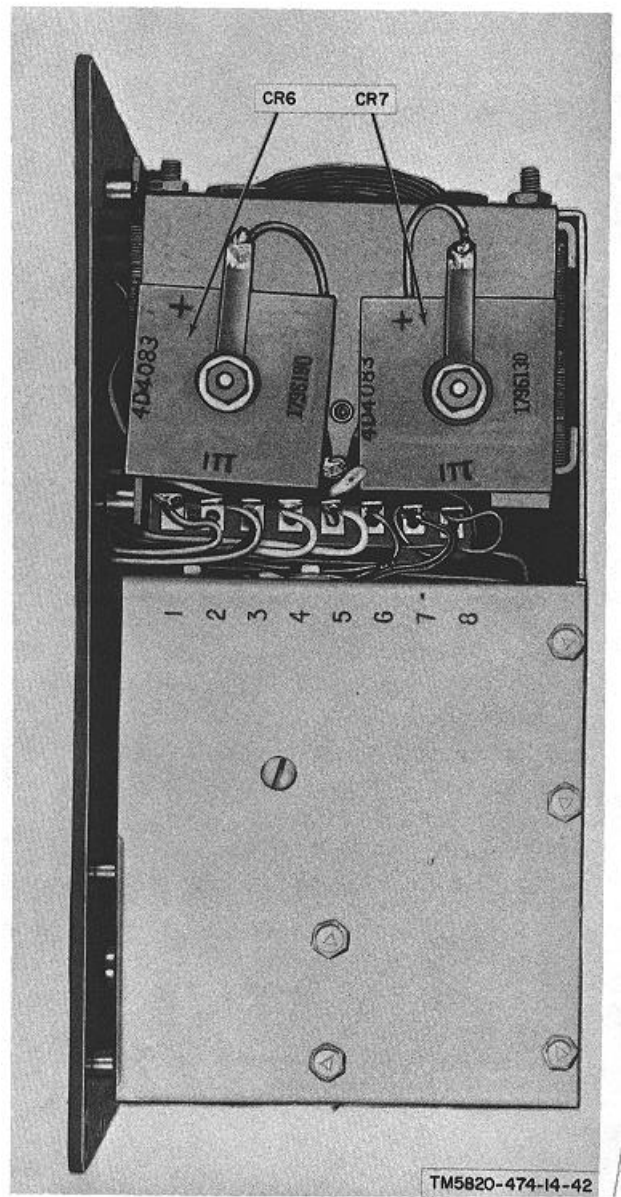

Figure 42. Small power supply, right side view.

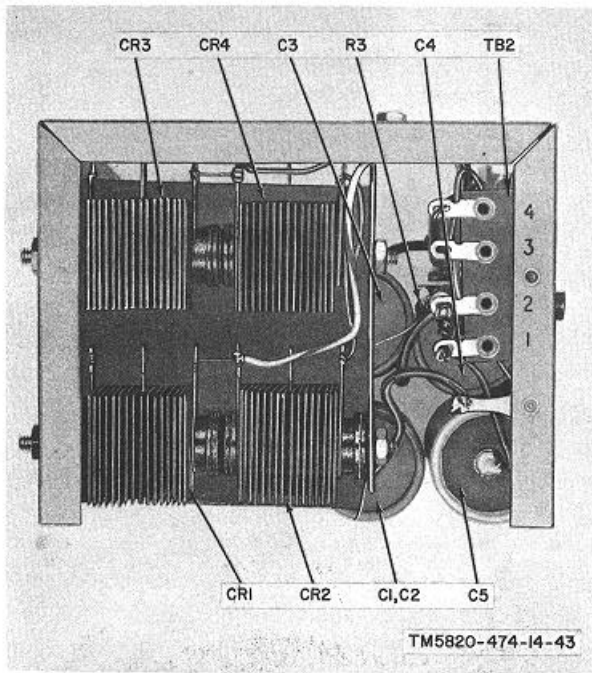

Figure 43. Small power supply, bottom view.

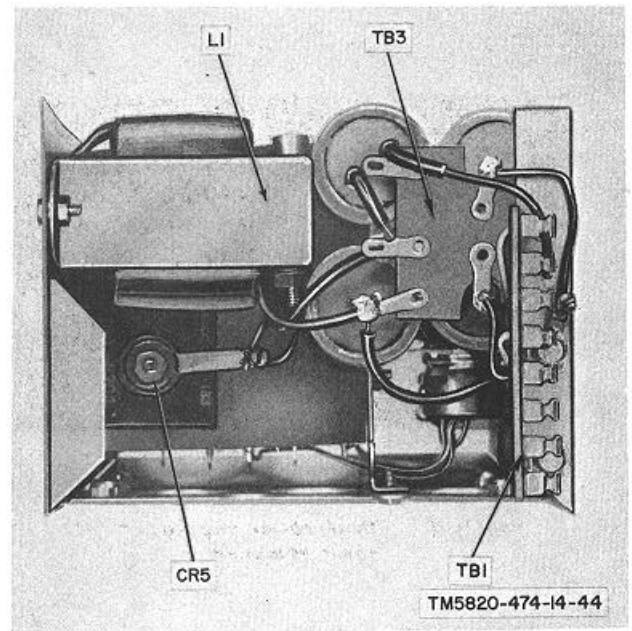

Figure 44. Small power supply, underside of chassis.

Section VI. TROUBLESHOOTING VOLTAGE REGULATOR CN-690/GRC-109

85. General

The voltage regulator is an accessory unit supplied with the radio set and may be used in place of the large power supply when the receiver and transmitter are operated from the hand-cranked generator. The voltage regulator is used to regulate B+ and filament voltages from the hand-cranked generator for the receiver. Transmitter B+ and filament voltages pass from the hand-cranked generator through the voltage regulator unaltered. Part locations in the voltage regulator are shown in figure 45; figure 60 is the schematic diagram.

86. Troubleshooting

Troubleshooting the voltage regulator consists mainly of continuity checks and resistance measurements. If the receiver filament voltage is excessively high, check selenium rectifier CR1 (fig. 45) by substitution. If the receiver B+ voltage is excessively high, check voltage regulator V1 by substitution.

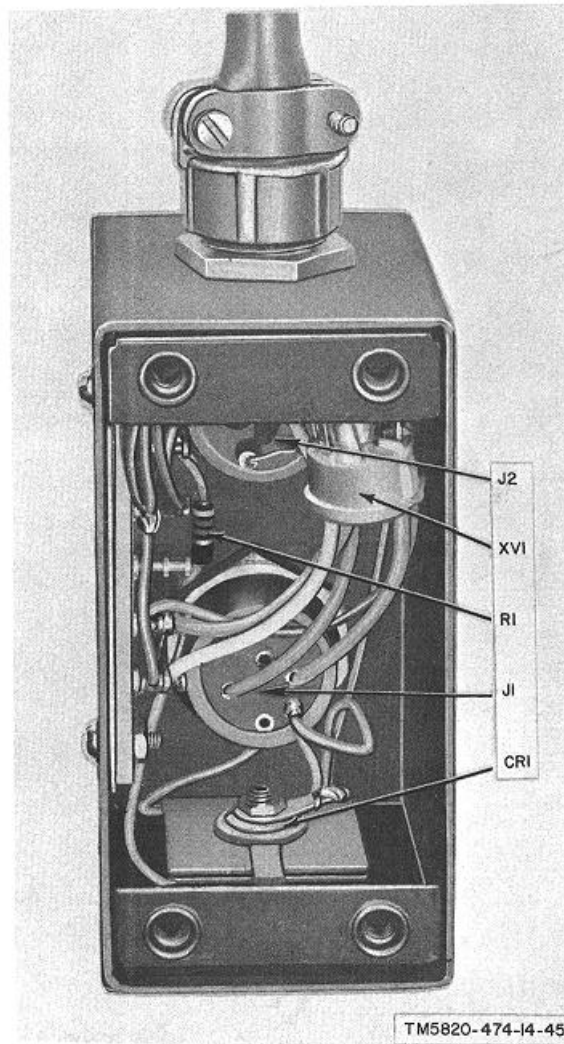

Figure 45. Voltage regulators interior view, V1 and mounting bracket removed.

CHAPTER 8

REPAIRS AND ALIGNMENT

Note. All repairs and alignment may be performed by third or fourth echelon personnel.

87. General Parts Replacement Techniques

Warning: The OB2 tube contains radioactive material. Handle carefully to avoid breakage.

Parts in the transmitter and in the two power supplies can be reached easily and replaced without special precautions. Special precautions are required in the receiver, because the internal construction is extremely compact. Careless replacement of parts in the receiver may result in damage to adjacent parts or unsatisfactory performance caused by incorrect placement of critical leads or parts. For soldering operations in the receiver, use a pencil-type iron with a maximum capacity of 25 watts. Before removing a part in the rf amplifier and converter circuits, note the position, of the part and its leads. Install replacement parts in essentially the same position as the original part to avoid undesired coupling and spurious oscillations.

a. If regulator CR7 in the large power supply must be replaced, make the following adjustments before connecting the receiver to the large power supply:

- (1) Replace CR7.
- (2) Connect a 4.5-ohm, 1-watt resistor across pins 1 and 4 of RCVR PWR. plug P5.
- (3) Operate the power supply from a fully charged 6-volt battery.
- (4) Set the multimeter for dc volts and connect it across the 4.5-ohm resistor (positive probe to pin 4).
- (5) Locate resistors R3 and R4 (fig. 38).
- (6) Adjust the slider on R4 until the multimeter indicates 1.3 volts.
- (7) Disconnect the 6-volt battery.
- (8) Connect the variable transformer (para 63) between an ac supply and the ac input to the large power supply.
- (9) Adjust the voltage selector dial on the variable transformer until the ac input to the power supply is exactly 110 volts.
- (10) Turn the power selector switch (fig. 10) on the power supply to 110.
- (11) Adjust the slider on R3 until the multimeter connected across the 4.5ohm resistor indicates 1.3 volts. Do not readjust R4.

b. If regulator CR5 in the small power supply must be replaced, make the following adjustments before connecting the receiver to the small power supply:

- (1) Replace CR5.
- (2) Connect a 4.5-ohm, one-watt resistor across pins 1 and 4 of RCVR PWR. plug P2.
- (3) Set the multimeter for dc volts and connect it across the 4.5-ohm resistor (positive probe to pin 4).
- (4) Connect the variable transformer between an ac supply and the ac input to the power supply.
- (5) Adjust the voltage selector dial on the variable transformer until the ac input to the small power supply is exactly 110 volts.
- (6) Turn the power selector switch on the small power supply to 110.
- (7) Remove the small cover at the top center of the front panel (fig. 41).
- (8) Adjust the slider on R1 until the voltmeter connected across the 4.5ohm resistor indicates 1.3 volts.

88. Test Equipment and Special Tools Required for Receiver Alignment Tests

| Item | Applicable technical manual | Common name |
|--------------------------------|-----------------------------|------------------|
| Signal Generator AN, URM-25A. | TM 11-5551A | Signal generator |
| Electronic Voltmeter ME-30A/U. | TM 11-6625-320-12 | Ac vtm |
| Seven-pin test socket adapter. | | |
| Resistor, 4,000 ohms, 1 watt. | | |
| Insulated alignment tool. | | |

89. Alignment Instructions

Align the receiver as instructed in paragraphs 90 through 92. Refer to figures 19 and 20 for the location of components. Use the insulated alignment tool for adjusting transformers and coils.

90. If. Alignment Procedure

Note: Locations of if. transformers are shown in figure 19.

a. Set the signal generator to 455 kc, 30-percent modulation at 400 cps.

b. Remove V2, replace it with the test socket adapter, and insert V2 into the test adapter.

c. Couple the signal generator through the CX-1.363/U test lead (part of the signal generator) to pin 6 of the test adapter.

d. Connect the ac vtm to PHONES jacks J3 and J4.

e. Connect the 4,000-ohm resistor in parallel with the ac vtm at the PHONES jacks.

f. Set the receiver TUNING control to 3 mc, short the ANT post to the GRD post with a jumper wire, and turn the BEAT OSC control to OFF.

g. Turn the GAIN control two thirds down from the MAX position.

h. Set the rf signal generator output to give a reference reading of 5 volts on the ac vtm.

i. Adjust both tuning slugs in if. transformer T3 to obtain maximum indication on the ac vtm. Adjust the output level of the signal generator as necessary to maintain approximately 5 volts on the ac vtm.

j. Adjust both tuning slugs in if. transformer T2 to obtain maximum indication on the ac vtm.

k. Adjust both tuning slugs in if. transformer T1 to obtain maximum indication on the ac vtm.

l. Adjust the transformer slugs a second time in the order indicated in *i* through *k* above.

91. Rf Alignment Procedure

Locations of adjustable coils and capacitors in the rf section are shown in figure 20. Connect the 4,000-ohm resistor and the ac vtm in parallel across the PHONES jacks. Connect the signal generator output through the Impedance Adapter MX-1074/ URM-25 (part of the signal generator) to the ANT and GRD posts. Reduce the output of the rf signal generator as necessary during

alignment to maintain a constant reading on the ac vtm.

a. *Alignment of Band 1 (3 to 6 Mc).*

(1) Set the RANGE switch to 1.

(2) Set the signal generator to 3 mc, 30-percent modulation at 400 cps.

(3) Set the receiver TUNING control to 3 me, the GAIN control to two thirds down from MAX, and turn the BEAT OSC control to OFF.

(4) Adjust L7 for maximum output on the ac vtm.

(5) Set the receiver TUNING control and signal generator to 3.2 me and adjust L1 and LA for maximum output on the ac vtm.

(6) Set the receiver TUNING control and the signal generator to 6 me and adjust C7 for maximum output on the ac vtm.

Note: Look for two peaks and select the one that corresponds to the least capacitance in C7.

(7) Set the receiver TUNING control and the signal generator to 5.5 me and adjust capacitors C1 and C4 for maximum output on the ac vtm.

b. *Alignment of Band 2 (6 to 12 Mc).*

(1) Set the RANGE switch to 2.

(2) Set the signal generator to 6 me, 30-percent modulation at 400 cps.

(3) Set the receiver TUNING control to 6 me, the GAIN control to two thirds down from MAX, and turn the BEAT OSC control to OFF.

(4) Adjust L8 for maximum output on the ac vtm.

(5) Set the receiver TUNING control and the signal generator to 6.5 mc and adjust L2 and L5 for maximum output on the ac vtm.

(6) Set the receiver TUNING control and the signal generator to 12 mc and adjust C8 for maximum output on the ac vtm.

Note: Look for two peaks and select the one that corresponds to the least capacitance in C8.

- (7) Set the receiver TUNING and the signal generator to 11.5 mc and adjust C2 and C5 for maximum output on the ac vtm.
- c. *Alignment of Band 3 (12-24 Mc).*
- (1) Set the RANGE switch to 3.
 - (2) Set the signal generator to 12 mc, 30-percent modulation at 400 cps.
 - (3) Set the receiver TUNING control to 12 mc, the GAIN control to two thirds down from MAX, and turn the BEAT OSC control to OFF.
 - (4) Adjust L9 for maximum output on the ac vtm.
 - (5) Set the receiver TUNING control and the signal generator to 13 mc and adjust L3 and L6 for maximum output on the ac vtm.
 - (6) Set the receiver TUNING control and the signal generator to 24 mc and adjust C9 for maximum output on the ac vtm.

Note: Look for two peaks and select the one that corresponds to the least capacitance in C9.

- (7) Set the receiver TUNING control and the rf signal generator to 22 mc and adjust C3 and C6 for maximum output on the ac vtm.

92. Adjustment and Check of Beat-Frequency Oscillator

The slug of coil L10, referred to in d below, protrudes from the bfo assembly shown in figure 19. Connect the output of pie rf signal generator to pin 6 of V2. Connect the headset to the PHONES jack on the receiver.

- a. Set the rf signal generator to 455 kc; turn the modulation off.
- b. Turn the GAIN control to the normal reception level (about two thirds from MAX).
- c. Set the BEAT OSC control to 0.
- d. Adjust the slug in L10 to obtain a zero beat. If the tuning is broad, increase the clockwise setting of the GAIN control.
- e. Rotate the BEAT OSC control to position 2 on one side of 0; then to position 2 on the other side of 0. At either position 2 setting, a high beat note (approximately 4 kc) should be heard.

CHAPTER 9

GENERAL SUPPORT TESTING PROCEDURES

93. General

a. Testing procedures are prepared for use by Electronic Field Maintenance Shops and Electronic Service Organizations responsible for general support maintenance of electronic equipment to determine the acceptability of repaired signal equipment. These procedures set forth specific requirements that repaired signal equipment must meet before it is returned to the using organization. The testing procedures may also be used as a guide for the testing of equipment that has been repaired at third echelon if the proper tools and test equipment's are available. A summary of the performance standards is given in paragraph 107.

b. Comply with the instructions preceding the chart before proceeding to the chart. Perform each test in sequence. Do not vary the sequence. For each step, perform all the actions required in the *Test equipment control settings and Equipment under test control settings* columns; then perform each specific test procedure and verify it against its performance standard.

94. Test Equipment, Tools, and Materials

All test equipment, tools, materials, and other equipment required to perform the testing procedures given in this section are listed in the charts below and are authorized under TA 11-17 and TA 11-100(11-17).

a. Test Equipment.

| Nomenclature | Federal stock No. | Technical manual |
|--|-------------------|-------------------|
| Multimeter TS-352(*) U ^a , | 6625-242-5023 | TM 11-5527 |
| Audio Oscillator TS-382(*) U ^b . | 6625-192-5094 | TM 11-6625-261-12 |
| Electronic Voltmeter ME-30(*) U ^c . | 6625-669-0742 | TM 11-6625-320-12 |
| R.F. Signal Generator Set AN URM-25A | 6625-309-5381 | TM 11-5551A |

| Nomenclature | Federal stock No. | Technical manual |
|--|-------------------|-------------------|
| Variable Power Transformer CN-16(*) U ^d . | 5950-235-2086 | |
| Multimeters | | TM 11-6625-200-12 |

| | | |
|---|---------------|-------------------|
| ME-26A U, ME-26B U, and ME-26C U. Wattmeter AN URM-120. | 6625-790-2746 | TM 11-6625-446-15 |
|---|---------------|-------------------|

^a Indicates TS-352 U, TS-352A U, and TS-352B U.

^b Indicates TS-382 U, TS-382A U, TS-382B U, TS-382E U, and TS-382F U.

^c Indicates ME-30 U, ME30A U, ME-30B U, and ME-30C U.

^d Indicates CN-16 U and CN-16B U.

b. Tools and Materials.

- (1) Insulated alignment tool.
- (2) Resistor, fixed, noninductive, 50 ohms, 20 watts.
- (3) Resistor, fixed, wirebound, 4.500 ohms, 10% 50 watts.
- (4) Resistor, fixed, wirebound 4.2 ohms, 10%, 50 watts.
- (5) Resistor, fixed, wirebound 5,000 ohms, 10%, 5 watts.
- (6) Resistor, fixed, composition 4.5 ohms, 10%, 1 watt.
- (7) Resistor, fixed, composition 4,000 ohms, 10%, 1 2 watt.
- (8) Storage battery, 6-volt.

c. Other Equipment.

| Equipment | Federal stock No. | Technical Manual |
|--|-------------------|------------------|
| Continental adapter (to convert round European-type power pins to flat American type). | None | None. |
| Set-up transformer, 1:2 turns ratio. | None | None. |

95. Fabrication of Special Test Leads

a. *Test Cable No. 1* (fig. 46). Test cable No. 1 is used to connect the output of the CN-16 (*) U to the primary of the step-up transformer when either power supply is tested. One cable is required.

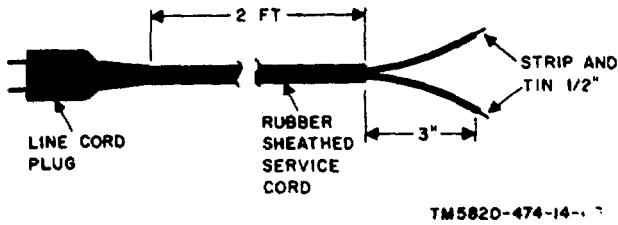

Figure 46. Test Cable No. 1, construction details.

b. Test Cable No. 2 (fig. 47). Test cable No. 2 is used to connect the secondary of the step-up transformer to the ac input power cable when either power supply is tested. One cable is required.

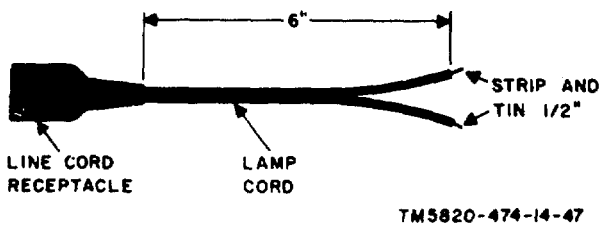

Figure 47. Test cable No. 2, construction details.

c. Test Cable No. 3 (fig. 48). Test cable No. 3 is used to connect the RCVR PWR jack to the dummy load resistors when either power supply is tested. One cable is required.

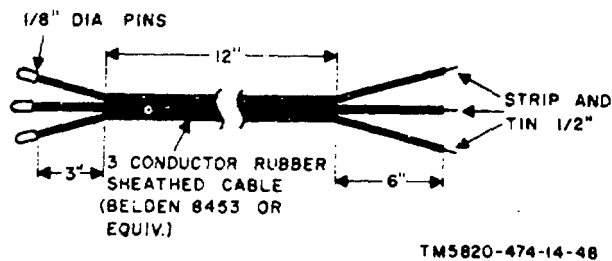

Figure 48. Test cable No. 3, construction details.

d. Test Cable No. 4 (fig. 49). Test cable No. 4 is used to connect the TRANS PWR jack to the dummy load resistors when either power supply is tested. One cable is required.

5 PIN CONNECTOR
(AMPHENOL 91-5M
OR EQUIV.)

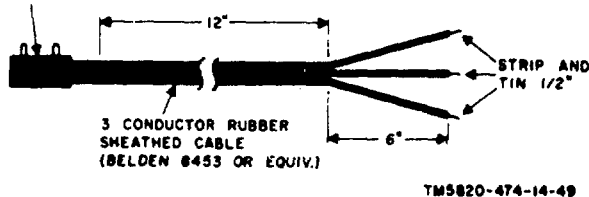

Figure 49. Test cable No. 4, construction details.

e. Test Cable No. 5 (fig. 50). Test cable No. 5 is a general-purpose test lead. It is used in several tests to connect test points to equipment input terminals. Four cables are required.

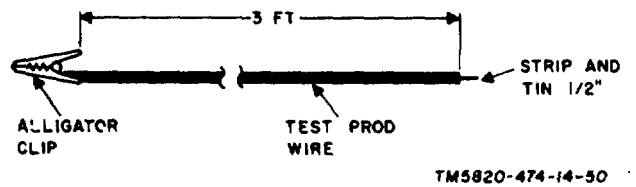

Figure 50. Test cable No. 5, construction details.

f. Test Cable No. 6 (fig. 51). Test cable No. 6 is used to connect the output of the transmitter to the input of the AN/URM120 when transmitter output power is tested. One cable is required.

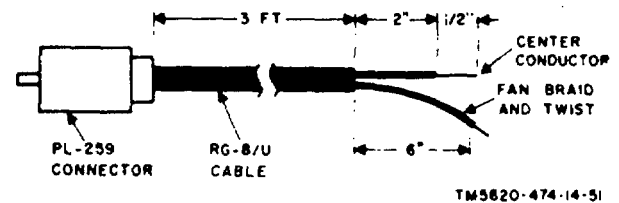

Figure 51. Test cable No. 6, construction details.

g. Test Cable No. 7 (fig. 52). Test cable No. 7 is used to connect the output of the AN/URM-25A impedance adapter to the input of the receiver. One cable is required.

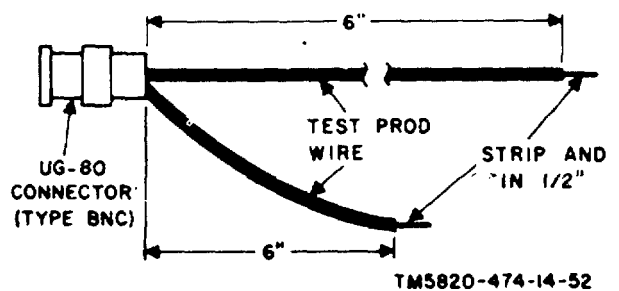

Figure 52. Test cable No. 7, construction details.

96. Power Supply PP-2684/GRC-109 Physical Tests and Inspection

- a. *Test Equipment and Materials.* None.
- b. *Test Connections and Conditions.* Do not connect the large power supply to a power source.
- c. *Procedure.*

| Test equipment control settings | Equipment under test control settings | Test procedure | Performance standard |
|---------------------------------|---------------------------------------|--|---|
| N/A | Controls may be in any position | <ul style="list-style-type: none"> a. Inspect the large power supply case and panel for loose or missing parts, damage, and condition of finish. b. Inspect the power cables and plugs for damage and signs of deteriorated insulation. c. Turn the power selector switch and the CHARGE-OPERATE switch to each of the indicated-positions. d. Remove the fuseholders and inspect them for damage; inspect the fuses for proper size and rating. | <ul style="list-style-type: none"> a. No damage or loose or missing parts are evident. External surfaces do not show bare metal. Panel lettering is legible. b. The power cables and plugs are in good condition, free from damage and deteriorated insulation. c. The switches operate freely without binding or excessive looseness. The switch detents are positive. The knobs are tight on the shafts and are properly indexed. d. The fuseholders are in serviceable condition. The fuses are of the proper value as indicated on the panel. |

97. Power Supply PP-2685/GRC-109 Physical Tests and Inspection

- a. *Test Equipment and Materials.* None.
- b. *Test Connections and Conditions.* Do not connect the small power supply to a power source.
- c. *Procedure.*

| Test equipment control settings | Equipment under test control settings | Test procedure | Performance standard |
|---------------------------------|---------------------------------------|---|--|
| N/A | Controls may be in any position | <ul style="list-style-type: none"> a. Inspect the small power supply case and panel for loose or missing parts, damage, and condition of finish. b. Inspect the power cable and plug for damage and signs of deteriorated insulation. c. Turn the power selector switch to each of the indicated positions. d. Remove the fuseholder and inspect it (for damage; inspect the fuse for proper size and rating. | <ul style="list-style-type: none"> a. No damage or loose or missing parts are evident. External surfaces, do not show bare metal. Panel lettering is legible. b. The power cable and plug are in good condition, free from damage and deteriorated insulation. c. The switch operates freely without binding or excessive looseness. The switch detents are positive. The knob is tight on the shaft and is properly indexed. d. The fuseholder is in serviceable condition. The fuse is rated at 2 amp. |

98. Radio Transmitter T-784/GRC-109 Physical Tests and Inspection

- a. *Test Equipment and Materials.* None.
- b. *Test Connections and Conditions.* Do not connect the transmitter to a power supply.
- c. *Procedure.*

| Test equipment control settings | Equipment under test control settings | Test procedure | Performance standard |
|---------------------------------|---------------------------------------|---|---|
| N/A | Controls may be in any position | <ul style="list-style-type: none"> a. Inspect the transmitter case and panel for loose or missing parts, damage, and condition of finish. b. Inspect the power cable and plug for damage and signs of deteriorated insulation. c. Turn the BAND switch to each of the indicated positions. The switch detents are positive. The knob is tight on its shaft and is properly indexed. d. Rotate the TUNE control and controls (2) and (3) throughout their range. e. Press the telegraph key down and release. | <ul style="list-style-type: none"> a. No damage or loose or missing parts are evident. External surfaces do not show bare metal. Panel lettering is legible. b. The power cable and plug are in good condition, free from damage and deteriorated insulation. c. The BAND switch operates freely without binding or excessive looseness. The d. Controls rotate freely without binding or excessive looseness. e. Telegraph key operates freely and returns under spring tension; lateral movement of key is slight. |

99. Radio Receiver R-1004/GRC-109 Physical Tests and Inspection

- a. *Test Equipment and Materials.* None.
- b. *Test Connections and Conditions.* Do not connect the receiver to a power supply.
- c. *Procedure.*

| Test equipment control settings | Equipment under test control settings | Test procedure | Performance standard |
|---------------------------------|---------------------------------------|--|--|
| N/A | Controls may be in any position | <ul style="list-style-type: none"> a. Inspect the receiver case and panel for loose or missing parts, damage, and condition of finish. b. Inspect the power cable and plug for damage and signs of deteriorated insulation. c. Turn the RANGE switch to each of the indicated positions. The switch detents are positive. The knob is tight on its shaft and is properly indexed. d. Rotate BEAT o8C, GAIN, and TUNIN controls throughout their range. | <ul style="list-style-type: none"> a. No damage or loose or missing parts are evident. External surfaces do not show bare metal. Panel lettering is legible. b. The power cable and plug are in good condition, free from damage and deteriorated insulation. c. The RANGE switch operates freely without binding or excessive looseness. The d. Controls will rotate freely without binding or excessive looseness. |

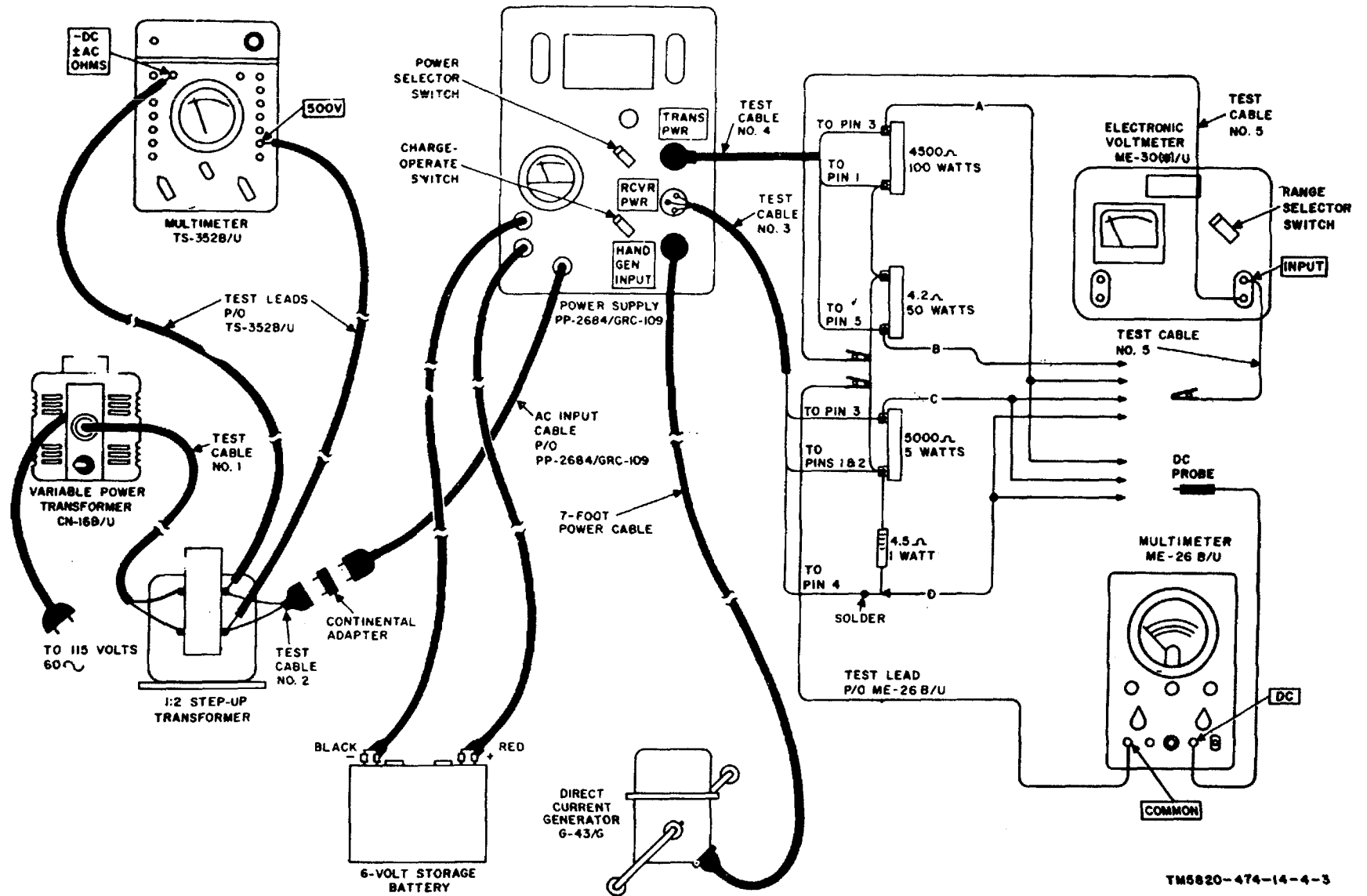

TM5820-474-14-4-3

Figure 53. Power Supply PP-2684/GRC-109, output voltage and ripple tests.

101. Power Supply PP-2685/GRC-109 Output Voltage and Ripple Tests

a. Test Equipment and Materials.

Multimeter TS-352(*)/U
 Electronic Voltmeter ME-30(*)/U
 Electronic Multimeter TS-505(*)/U
 Variable Power Transformer CN-16(*)/U
 Step-up transformer, 1:2 turns ratio
 Continental adapter
 Test cable No. 1
 Test cable No. 2
 Test cable No. 3
 Test cable No. 4
 Test cable-No. 5 (2)
 Resistor, 4,500 ohms, 100 watts
 Resistor, 4.2 ohms, 50 watts
 Resistor, 5,000 ohms, 5 watts
 Resistor, 4.5 ohms, 1 watt

b. Test Connections and Conditions. Connect the equipment as shown in figure 54. Turn on the test equipment and allow 15 minutes to warm up before proceeding. Be sure the voltage selector dial on the CN-16(*)/U is set to zero.

c. Procedure.

| Step No. | Test equipment Control settings | Equipment under test control settings | Test procedure | Performance standard |
|----------|--|--|--|---|
| 1 | TS-352(*)/U: FUNCTION: AC VOLTS ME-30(*)/U: Range selector switch: 10V. TS-505 (*)/U: FUNCTION: +D. C. RANGE: 1000V | PP-2685/CRC-109: Power selector switch: 220 | a. Connect the test leads from the ME-30(*)/U and the TS-505(*)/U to agree with connection A, figure 54. b. Adjust the voltage selector dial on the CN-16(*)/U for an indication of 220 volts on the TS-352(*)/U. c. Note the indication on the ME-30(*)/U. d. Note the indication on the TS-605(*)/U e. Adjust the voltage selector dial on the CN-16(*)/U for an indication of 75 volts on the TS-352(*)/U. f. Turn the power selector switch on the PP-2685/GRC-109 to 75. g. Note the indication on the ME-30(*)/U h. Note the indication on the TS505(*)/U i. Turn the power selector switch on the PP-2685/GRC-109 to 110. j. Adjust the voltage selector dial on the CN-16(*)/U for an indication of 110 volts on the TS-352(*)/U. k. Note the indication on the ME-30(*)/U l. Note the indication on the TS-505(*)/U | a. None. b. None. c. ME-30(*)/U indication is less than 10 volts. d. TS-505(*)/U indication 450 volts \pm 25. e. None. f. None. g. ME-30(*)/U indication is less than 10 volts. h. TS-505(*)/U Indication is 450 volts \pm 25. i. None. j. None. k. ME-30(*)/U indication is less than 10 volts. l. TS-505(*)/U indication is 450 volts \pm 25. |
| 2 | As last indicated | As last indicated | a. Connect the test lead from the ME-30(*)/U to agree with connection B, figure 54. b. Note the indication on the ME-930()/U c. Adjust the voltage selector dial on the CN-16(*)/U for an indication of 75 volts on the TS-352()/U. d. Turn the power selector switch on the PP-2685/GRC-109 to 75. e. Note the indication on the ME-30(*)/U f. Turn the power selector switch on the PP-2685/GRC-109 to 220. g. Adjust the voltage selector dial on the CN-16(*)/U for an indication of 220 volts on the TS-352(*)/U. h. Record the indication on the ME-30()/U | a. None. b. ME-30SO)/U indication is 6.3 volts \pm 0.4. c. None. d. None. e. ME-30(*)/U Indication is 6.3 volt \pm 0.4. f. None. g. None. h. ME-30(*)/U indication is 6.3 volts \pm 0.4. |
| 3 | As last indicated | As last indicated | a. Connect the test leads from the ME-30(*)/U and the TS-505(*)/U to agree with connection C, figure 54. b. Turn the range selector switch on the ME-30(*)/U to 0.1 volt. c. Turn the RANGE switch on the TS-505(*)/U to 200 V. d. Note the indication on the ME-30(*)/U e. Note the indication on the TS-505()/U f. Adjust the voltage selector dial on the CN-16(*)/U for an indication of 75 volts on the TS-352(*)/U. g. Turn the power selector switch on the PP-2685/GRC-109 to 75. h. Note the indication on the ME-30(*)/U i. Note the indication on the TS-505()/U j. Turn the power selector switch on the PP-2685/GRC-109 to 110. k. Adjust the voltage selector dial on the CN-16(*)/U for an indication of 110 volts on the TS-352(*)/U. l. Note the indication on the ME-30(*)/U m. Note the indication on the TS-505(*)/U | a. None. b. None. c. None. d. ME-30(*)/U indication is less than 0.04 volt. e. TS-505(*)/U indication is 100 volts \pm 10 f. None. g. None. h. ME-30(*)/U indication is less than 0.04 volts. i. TS-505(*)/U indication is 100 volts \pm 10. j. None. k. None. l. ME-30S)/U indication is less than 0.04 volt. m. TS-505(*)/U Indication is 100 volts \pm 10. |
| 4 | As last indicated | As last indicated | a. Connect the test leads from the IE-30(a)/U and the TS-505(*)/U to agree with connection D, figure 53. b. Turn the RANGE switch on the TS-505(*)/U to 2 V. c. Note the indication on the ME-30(*)/U d. Note the indication on the TS-505(*)/U e. Adjust the voltage selector dial on the CN-16(*)/U for an indication of 75 volts on the TS-3J52()/U. f. Turn the power selector switch on the PP-2684/GRC-109 to 75. g. Note the indication on the MI-30(*)/U 0.04 volt. h. Note the indication on the TS-505(*)/U i. Turn the power selector switch on the PP-2684/GRC-109 to 220. j. Adjust the voltage selector dial on the CN-16(*)/U for an indication of 220 volts on the TS-352(*)/U. k. Note the indication on the ME-30(*)/U l. Note the indication on the TS-505(*)/U | a. None. b. None. c. ME-30(*)/U indication is less than 0.04 volt. d. TS-505()/U indication is 1.35 volts \pm 0.1. e. None. f. None. g. ME-30(*)/U indication is less than 0.04 volt. h. TS-505(*)/U indication is 1.35 volts \pm 0.1. i. None. j. None. k. ME-30(*)/U indication is less than 0.04 volts. l. TS-505(*)/U indication is 1.35 volts \pm 0.1. |
| 5 | As last indicated | As last indicated | a. Turn the power selector switch on the PP-2684/GRC-109 to OFF. b. Unplug the PP-26.4/GRC-109 ac input cable. c. Disconnect the ME-30*)/U test leads d. Connect the test lead from the TS-505(*)/U to agree with connection A, figure 53. e. Turn the RANGE switch on the TS-505(*)/U to 1000 V. f. Turn the power selector switch on the PP-2684/GRC-109 to BAT. g. Note the indication on the TS-SCS*)/UL | a. None. b. None. c. None. d. None. e. None. f. None. g. TS-505(*)/U indication is 450 volts |
| 6 | As last indicated | As last indicated | a. On the PP-2654/CRC-109, remove the cover from the HAND GEN INPUT and connect the G-43/C (fig. 53). b. Turn the power selector switch on the PP-2684/GRC-109 to OFF. c. Operate the crank on the G-43/G at 60 rpm; note the indication on the TS-505(*)/U. | a. None. c. TS-505(*)/U indication is 450 volts \pm 25. |

This page intentionally left blank

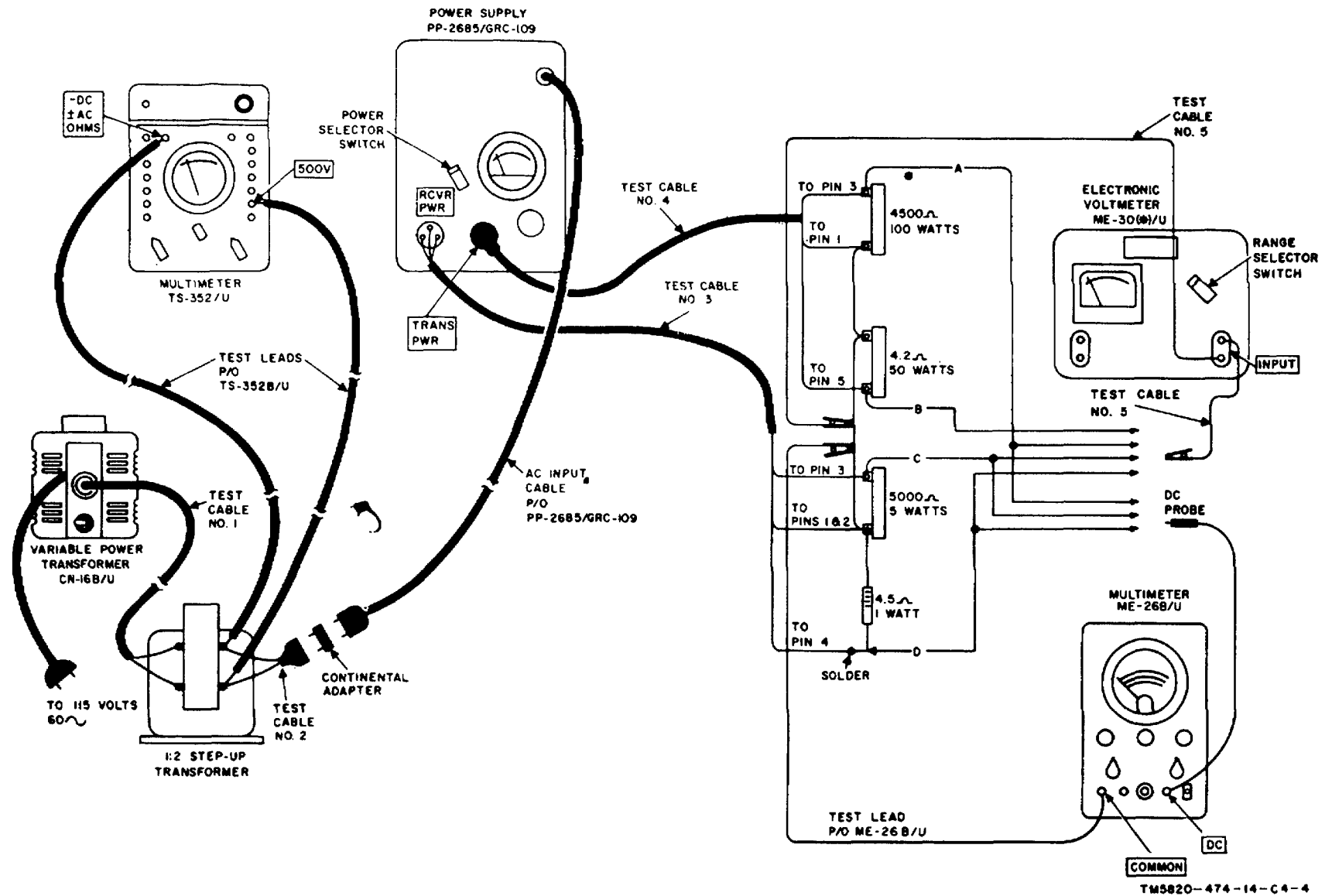

Figure 54. Power Supply PP-2685/GRC-109, output voltage and ripple tests.

100. Power Supply PP-2684/GRC-109 Output Voltage and Ripple Tests*a. Test Equipment and Materials.*

Multimeters TS-352(*)/U
 Electronic Voltmeter ME-30(*)/U
 Electronic Multimeter TS-505(*)/U
 Variable Power Transformer CN-16(*)/U
 Direct Current Generator G-43/G
 Storage battery, 6-volt
 7-foot power cable
 Test cable No. 1
 Test cable No. 2
 Test cable No. 3
 Test cable No. 4
 Test cable No. 5 (2)
 Step-up transformer, 1:2 turns ratio
 Continental adapter
 Resistor, 4,500 ohms, 100 watts
 Resistor, 4.2 ohms, 50 watts
 Resistor, 5,000 ohms, 5 watts
 Resistor, 4.5 ohms, 1 watt

b. Test Connections and Conditions. Connect the equipment, except the G-43/G, as shown in figure 53. Turn on the test equipment and allow it to warm up for 15 minutes before proceeding. Be sure the voltage selector dial on the CN16(*)/U is set to zero.

c. Procedure.

| Step No. | Test equipment Control settings | Equipment under test control settings | Test procedure | Performance standard |
|----------|---|---|---|--|
| 1 | TS-352(*) U: FUNCTION: AC VOLTS ME-30(*) U: Range selector switch: 10V. TS-352(*)/U. FUNCTION: D.C. RANGE: 1000V | PP-2684 GRC-109: Power selector switch: 220 CHARGE-OPERATE switch OPERATE. | <p>a. Connect the test leads from the ME-30(*)/U and the TS-505(*)/U to agree with connection A in figure 53.</p> <p>b. Adjust the voltage selector dial on the CN-16(*)/U for an indication of 220 volts on the</p> <p>c. Note the indication on ME-30(*)/U</p> <p>d. Note the indication on TS-505(*)/U</p> <p>e. Adjust the voltage selector dial on the CN-16(*)/U for an indication of 75 volts on the TS-352(*)/U.</p> <p>f. Turn the power selector switch on the PP-2684/GRC-109 to 75.</p> <p>g. Note the indication on ME-30(*)/U</p> <p>h. Note the indication on TS-505(*)/U</p> <p>i. Turn the power selector switch on the PP-2684/GRC-109 to 110.</p> <p>j. Adjust the voltage selector dial on UN-16(*)/U for an indication of 110V on the TS-352(*)/U.</p> <p>k. Record the indication on the ME-30(*)/U</p> <p>l. Record the indication on the TS-505(*)/U</p> | <p>a. None.</p> <p>b. None</p> <p>c. ME-30(*)/U indication is less than 5 volts.</p> <p>d. TS-505(*) indication is 450 volts ± 25.</p> <p>e. None.</p> <p>f. None.</p> <p>g. ME-30(*)/U indication is less than 5 volts.</p> <p>h. TS-505(*)/U indication is 450 volts ± 25.</p> <p>i. None.</p> <p>j. None.</p> <p>k. ME-30(*)/U indication is less than 5 volts.</p> <p>l. TS-505(*)/U indication is 450 volts ± 25.</p> |
| 2 | As last indicated | As last indicated | <p>a. Connect the test lead from the ME-30(*)/U to agree with connection B, figure 53.</p> <p>b. Note the indication on the ME-30(*)/U</p> <p>c. Adjust the voltage selector dial on the CN-16(*)/U for an indication of 75 volts on the TS-352(*)/U.</p> <p>d. Turn the power selector switch on the PP-2684/GRC-109 to 75.</p> <p>e. Note the indication on the ME-30(*)/U</p> <p>f. Turn the power selector switch on the PP-2684/GRC-109 to 220.</p> <p>g. Adjust the voltage selector dial on the CN-16(*)/U for an indication of 220 volts on the TS-352(*)/U.</p> <p>h. Note the indication on the ME-30(*)/U</p> | <p>a. None.</p> <p>b. ME-30(*)/U indication is 6.3 volts ± 0.4.</p> <p>c. None.</p> <p>d. None.</p> <p>e. ME-30(*)/U indication is 6.3 volts ± 0.4.</p> <p>f. None.</p> <p>g. None.</p> <p>h. ME-30(*)/U indication is 6.3 volts ± 0.4.</p> |
| 3 | As last indicated | As last indicated | <p>a. Connect the test leads from the ME-30(*)/U and the TS-505(*)/U to agree with connection C, figure 53.</p> <p>b. Turn the range selector switch on the ME-30(*)/U to 0.1 volt.</p> <p>c. Turn the RANGE switch on the TS-505(*)/U to 200 volts.</p> <p>d. Note the indication on the ME-30(*)/U</p> <p>e. Note and record indication on TS-505(*)/U</p> <p>f. Adjust the voltage selector dial on the CN-16(*)/U for an indication of 75 volts on the TS-352(*)/U.</p> <p>g. Turn the power selector switch on the PP-2684/GRC-109 to 75.</p> <p>h. Note the indication on the ME-30(*)/U</p> <p>i. Note the indication on the TS-505(*)/U</p> <p>j. Turn the power selector switch on the PP-2684-/GRC-109 to 110.</p> <p>k. Adjust the voltage selector dial on the CN-16(*)/U for an indication of 110 volts on the TS-352(*)/U.</p> <p>l. Note the indication on the ME-30(*)/U</p> <p>m. Note the indication on the TS-505(*)/U</p> | <p>a. None.</p> <p>b. None.</p> <p>c. None.</p> <p>d. ME-30(*)/U indication is less than ± 0.04 volt.</p> <p>e. TS-505(*)/U indication is 100 volts ± 10.</p> <p>f. None.</p> <p>g. None.</p> <p>h. ME-30(*)/U indication is less than 0.04 volt.</p> <p>i. TS-505(*)/U indication is 100 volts ± 10.</p> <p>j. None.</p> <p>k. None.</p> <p>l. ME-30(*)/U indication is less than 0.04 volt.</p> <p>m. TS-505(*)/U indication is 100 volts ± 10</p> |
| 4 | As last indicated | As last indicated | <p>a. Connect the test leads from the ME-30(*)/U and the TS-505(*)/U to agree with connection D, figure 54.</p> <p>b. Turn the RANGE switch on the TS-505(*)/U to 2 V.</p> <p>c. Note the indication on the ME-30(*)/U</p> <p>d. Note the Indication on the TS-505(*)/U</p> <p>e. Adjust the voltage selector dial on the CN-16(*)/U for an Indication of 75 volts on the TS-352(*)/U.</p> <p>f. Turn the power selector switch on the PP-2685/GRC-109 to 75.</p> <p>g. Note the indication on the ME-30(*)/U</p> <p>h. Note the Indication on the TS-505(*)/U</p> <p>i. Turn the power selector switch on the PP-2685/GRC-109 to 220V.</p> <p>j. Adjust the voltage selector dial on the CN-16(*)/U for an indication M 220 volts on the TS-352(*)/U.</p> <p>k. Record the indication on the ME-30(*)/U</p> <p>l. Record the indication on the TS-505(*)/U</p> | <p>a. None.</p> <p>b. None.</p> <p>c. ME-30(*)/U indication is less than 0.04 volt.</p> <p>d. TS-505(*)/U Indication is 1.35 volts ± 0.1.</p> <p>e. None.</p> <p>f. None,</p> <p>g. ME-30(*)/U indication is less than 0.04 volt.</p> <p>h. TS-505(*)/U indication 1.35 volts ± 0.1.</p> <p>i. None.</p> <p>j. None.</p> <p>k. ME-30(*)/U indication is less than 0.04 volt</p> <p>l. TS-505(*)/U indication is 1.35 volts ± 0.1.</p> |

This page left blank intentionally.

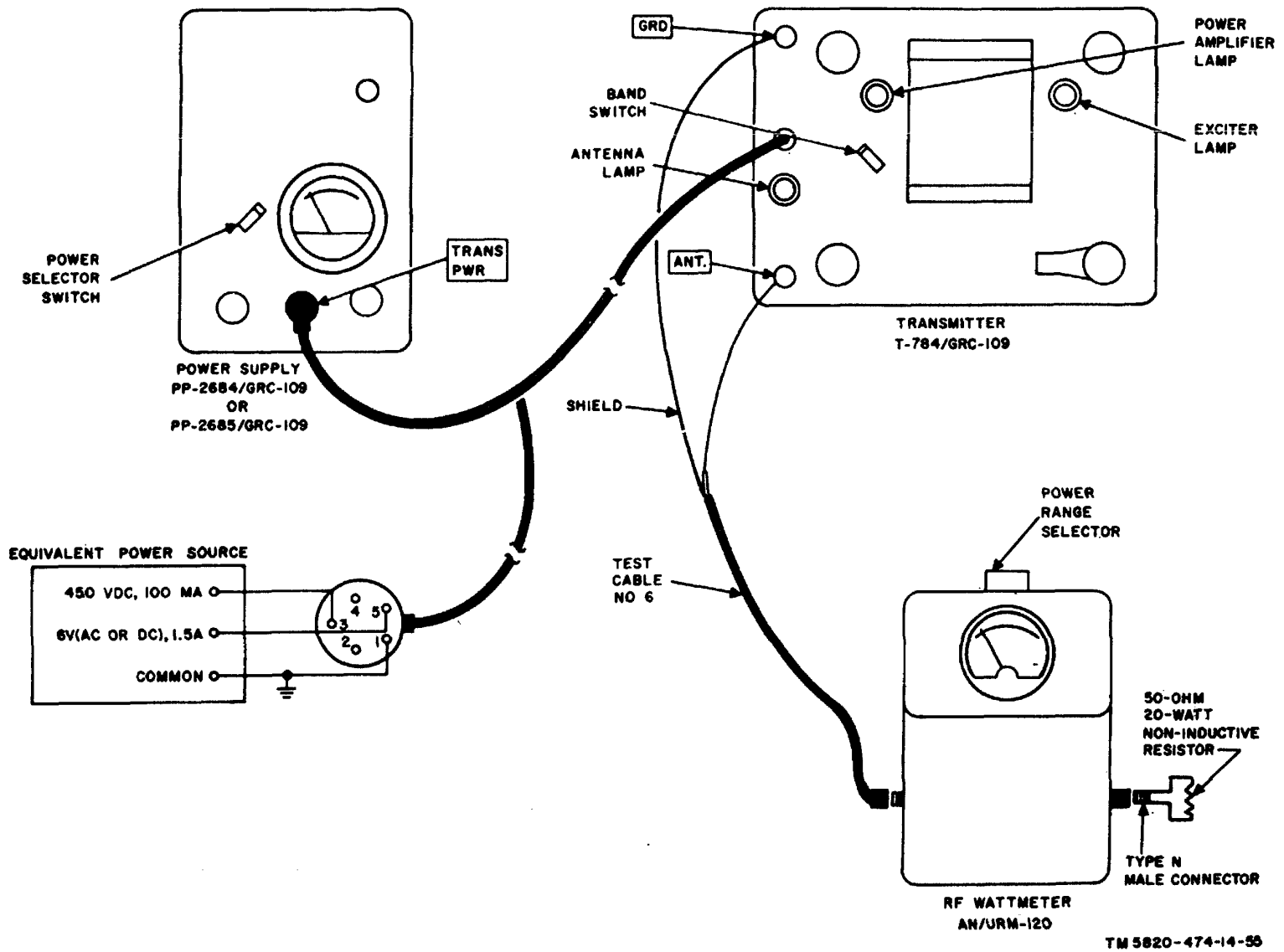

Figure 55. Transmitter power output test.

102. Radio Transmitter T-784/GRC-109 Power Output Test*a. Test equipment and Materials.*

wattmeter AN/URM-120

Power Supply PP-2684/GRC-109, PP-2685/GRC-109, or equivalent

Crystals, 3.0, 4.0, 4.5, and 5.5 mc

Test cable No. 6

b. Test Connections and Conditions. Connect the equipment as shown in figure 55. Turn on the equipment and allow 15 minutes to warm up before proceeding.

c. Procedure.

| Step No. | Test equipment Control settings | Equipment under test control settings | Test procedure | Performance standard |
|----------|---|---|--|---|
| 1 | AN/URM-120: Power range selector: 50 WATTS. PP-2684/GRC-109: Power selector switch: 110 CHARGE-OPERATE switch: OPERATE. | T-784/GRC-109: Band switch: Exciter tuning: 10 Power amplifier: 10 Antenna TUNE: LO Z 50 | a. Plug the 3-mc crystal into the crystal socket. b. Depress the key and adjust the exciter tuning control for maximum brilliance in the exciter lamp. c. Depress the key and adjust the power amplifier tuning control for maximum brilliance in the power amplifier lamp. d. Depress the key and adjust the antenna TUNE control for maximum brilliance in the antenna lamp. e. Repeat b, c, and d above f. Note the indication on AN/URM-120 | a. None. b. None. c. None. d. None. e. None. f. AN/URM-120 indication is more than 10 watts. |
| 2 | Same as step 1 | T-784/GRC-109: Band switch: 1 Exciter tuning: 95 Power amplifier: 95 Antenna TUNE: LO Z 50 | a. Remove the 3.0-mc crystal and insert the 5.5-mc crystal. b. Repeat step 1b through e c. Note the indication on the AN/URM-120 | a. None. b. None. c. AN/URM-120 indication is more than 5 watts. |
| 3 | Same as step 1 | T-784/GRC-109: Band switch: 2 Exciter tuning: 20 Power amplifier: 30 Antenna TUNE: LO Z 50 | Repeat step 1b through f with the 5.5-mc crystal installed. | Same as step 1a through f. |
| 4 | Same as step 1 | T-784/GRC-109: Band switch: 2 Exciter tuning: 75 Power amplifier: 85 Antenna TUNE: LO Z 50 | a. Remove 5.5-mc crystal and insert 4.5-mc crystal (9.0-mc output). b. Repeat step 1b through f | a. None. b. Same as step 1a through f. |
| 5 | Same as step 1 | T-784/GRC-109: Band switch: 3 Exciter tuning: 35 Power amplifier: 40 Antenna tune: LO Z 50 | Repeat step 1b through f with the 4.5-mc crystal installed (9.0-mc output). | Same as step 1a through f. |
| 6 | Same as step 1 | T-784/GRC-109: Band switch: 3 Exciter tuning: 85 Power amplifier: 95 Antenna TUNE: LO Z 50 | a. Remove the 4.5-mc crystal and install the 4.0-mc crystal (16-mc output). b. Repeat step 1b through f | a. None. b. Same as step 1a through f. |
| 7 | Same as step 1 | T-784/GRC-109: Band switch: 4 Exciter tuning: 60 Power amplifier: 80 Antenna TUNE: LO Z 50 | Repeat step 1b through f with the 4.0-mc crystal (16-mc output). | Same as step 1a through f. |
| 8 | Same as step 1 | T-784/GRC-109: Band switch: 4 Exciter tuning: 100 Power amplifier: 95 Antenna TUNE: LO Z 50 | a. Remove the 4.0-mc crystal and install the 5.5-mc crystal (22-mc output). b. Repeat step 1b through f. | Same as step 1a through f. |

This page left blank intentionally.

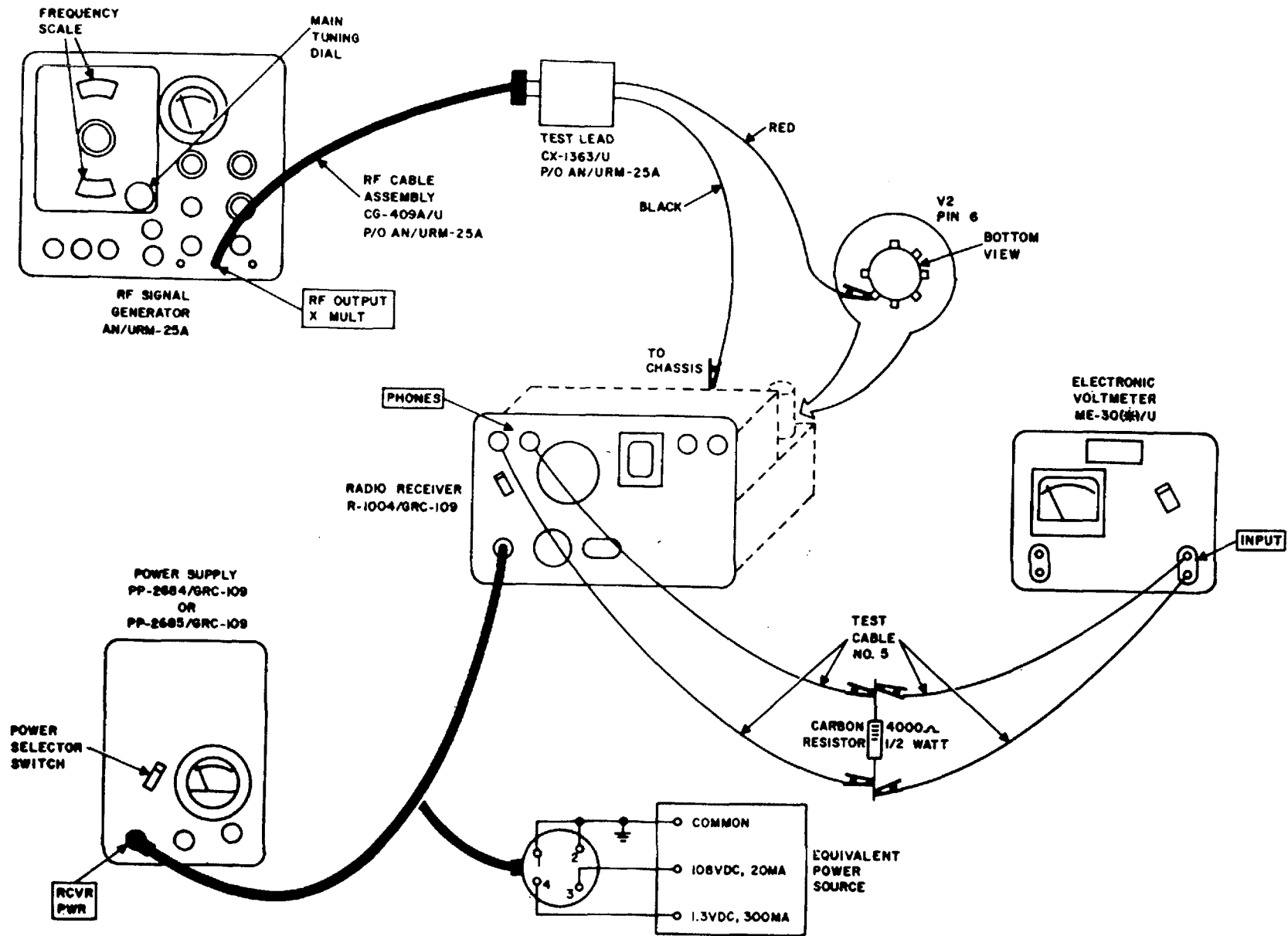

TM 5820-474-14-56

Figure 56. If. Bandwidth test.

101. Radio receiver R-1004/GRC-109 If. Bandwidth Test

a. Test Equipment and Materials.

- RF. Signal Generator Set AN/URM-25A
- Electronic Voltmeter ME-30(*)/U
- Resistor, noninductive, 50 ohms, 20 watts
- Resistor, 4,000 ohms, 1/2 watt
- Test cable No. 5 (4)
- Power Supply PP-2685/GRC-109 or PP-2684/GRC-109, or equivalent

b. Test Connections and Conditions. Connect the equipment as shown in figure 56. Turn on all equipment and allow 15 minutes to warm up before proceeding.

c. Procedure.

| Step No. | Test equipment Control settings | Equipment under test control settings | Test procedure | Performance standard |
|----------|--|--|--|---|
| 1 | <p><i>PP-2685/GRC-109:</i> Power selector switch: 110 <i>AN/URM-25A:</i> FREQUENCY BAND switch: D CARRIER CONTROL: maximum counterclockwise. CARRIER RANGE switch: D Main dial: 455 on the frequency scale. MULTIPLIER dial: 1000 % MODULATION control: maximum counterclockwise. MOD SELECTOR: 400 MICROVOLTS control: maximum counterclockwise. <i>ME. 30(*)/U:</i> RANGE SELECTOR switch: 10V</p> | <p><i>R-1004/GRC-109:</i> GAIN: 2/3 from MAX BEAT OSC: OFF</p> | <p><i>a.</i> Adjust main tuning dial on AN/URM-2SA to 455 kc <i>b.</i> Adjust % MODULATION control on AN/URM-25A for 30% modulation. <i>c.</i> Adjust MICROVOLTS control of AN/URM-25A to obtain reference reading of 5 volts on ME-30(*)/U. <i>d.</i> Note and record output level on AN/URM-2SA. This is the output reference level. <i>e.</i> Increase the output level from the AN/URM-25A 6 db (twice) above the reference level noted in <i>d</i> above. <i>f.</i> Turn the main tuning dial on the AN/URM-2SA to increase the output frequency above 455 kc until the ME-30(*)/U indicates 6 volts. <i>g.</i> Note and record the output frequency indicated on the AN/URM-25A. <i>h.</i> Turn the main tuning dial on the AN/URM-25A to decrease the output frequency below 455 kc until the ME-30(*)/U indicates 5 volts. <i>i.</i> Note the output frequency indicated on the AN/URM-25A. <i>j.</i> Increase the rf output level from the AN/UR-25SA 60 db (1,000 times) above the reference level noted in <i>d</i> above. <i>k.</i> Turn the main tuning dial on the AN/URM-2SA to increase the output frequency above 455 kc until the ME-30(*)/U indicates 5 volts. <i>l.</i> Note the output frequency indicated on the AN/URM-25A. <i>m.</i> Turn the main tuning dial on the AN/URM-26A to decrease the output frequency below 455 kc until the ME-30(*)/U indicates 5 volts. <i>n.</i> Note the output frequency indicated on the AN/URM-25A.</p> | <p><i>a.</i> None. <i>b.</i> None. <i>c.</i> None. <i>d.</i> None. <i>a.</i> None. <i>f.</i> ME-30(*)/U indication is 5 volts. <i>g.</i> AN/URM-25 indication is higher than 459.5 kc. <i>h.</i> None. <i>i.</i> AN/URM-2A indication is not lower than 450.6 kc. <i>j.</i> None. <i>k.</i> ME-30(*)/U indication is 5 volts. <i>l.</i> AN/URM-2SA indication: not higher than 470 kc. <i>m.</i> None. <i>n.</i> AN/URM-25A indication is not lower than 440 kc.</p> |

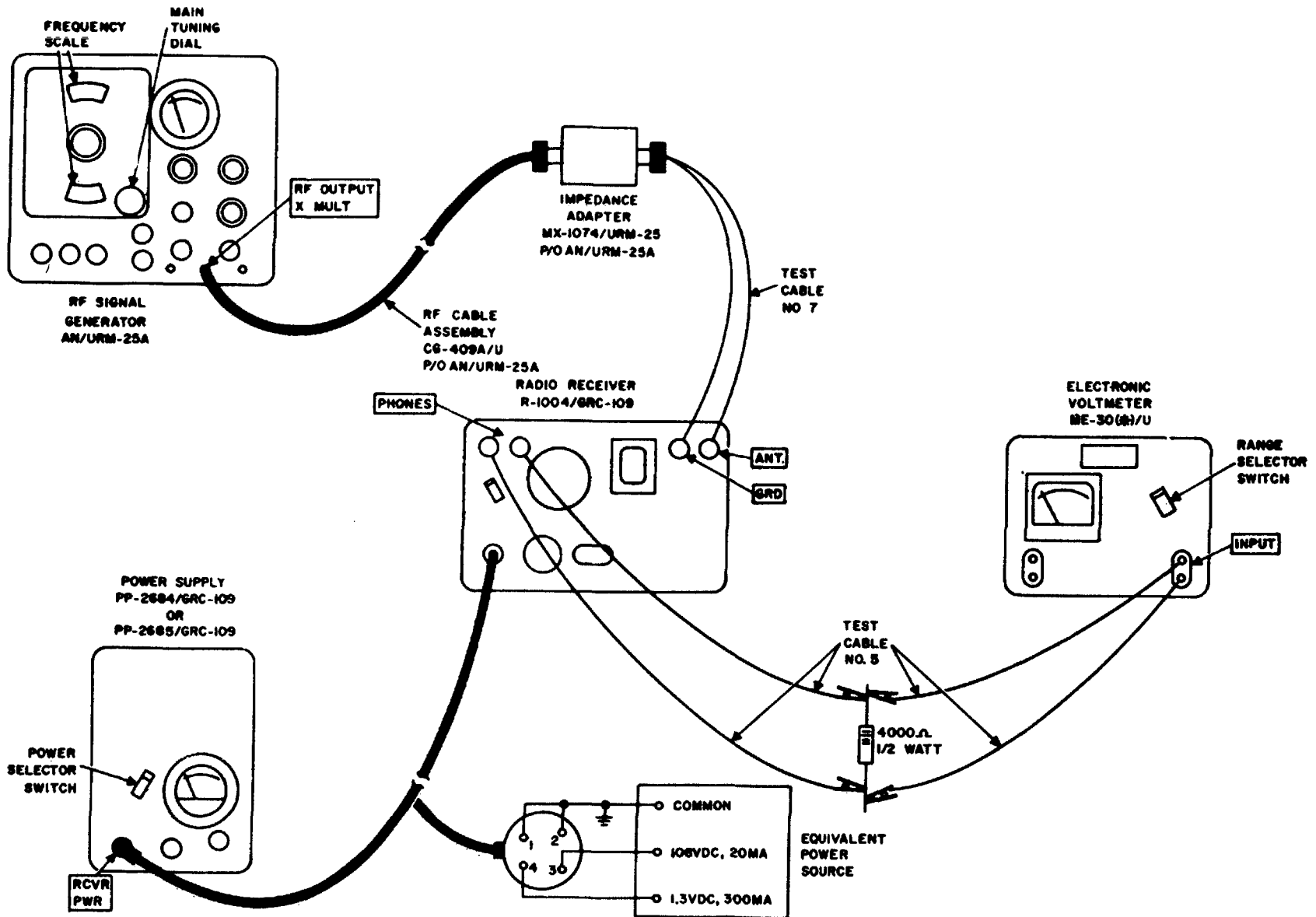

TM 5820-474-14-57

Figure 57. Receiver signal-to-noise ratio test.

104. Radio Receiver R-1004/GRC-109 Signal-to-Noise Ratio Test

a. Test Equipment and Materials.

- R. F. Signal Generator Set AN/URM-25A
- Electronic Voltmeter ME-30(*)/U
- Resistor, 4,000 ohms, 1/2 watt
- Power Supply PP-2685/GRC-109, PP-2684/GRC-109, or equivalent
- Test cable No. 5 (4)
- Test cable No. 7

b. Test Connections and Conditions. Connect the equipment as shown in figure 57. Turn on the test equipment and allow 15 minutes to warm up before proceeding.

c. Procedure.

| Step No. | Test equipment Control settings | Equipment under test control settings | Test procedure | Performance standard |
|----------|---|---|---|--|
| 1 | <i>PP-2685/GRC-109:</i> Power selector switch: 110 <i>AN/URM-25A:</i> FREQUENCY BAND switch: F CARRIER CONTROL: maximum-counterclockwise. CARRIER RANGE switch: D Main tuning dial: 3.0 on the frequency scale. MULTIPLIER dial: 1000 % MODULATION control: maximum counterclockwise. MOD SELECTOR: 400 MICROVOLTS control: maximum counterclockwise. ME-30(*)/U: Range selector switch: 0 DB | <i>R-1004/GRC-109:</i> GAIN: 2/3 from MAX BEAT OSC: OFF RANGE: 1 TUNING: 3 mc | a. Disconnect the output of the AN/URM-25A from the input to the R-1004/GRC-109. b. Record the indication (in db) on the ME-30(*)/U. This is the noise level of the receiver. c. Reconnect the output of the AN/URM-25 to-the input of the R-1004/GRC-109. d. Adjust the output level of the AN/URM-25A to 5 microvolts, modulated 30%. e. Record the indication (in db) on the ME-30(*)/U f. Subtract the level obtained in <i>b</i> above from the level obtained in <i>e</i> above. This difference is the signal-to-noise ratio. | a. None. b. None. c. None. d. None. e. None. f. Difference in levels is 10 db or greater. |
| 2 | Same as step 1 except: <i>AN/VURM-23A:</i> Main tuning dial: 6.0 mc | Same as step 1 except: TUNING: 6 mc | Repeat step 1a through <i>f</i> at 6.0 mc | Same as step 1a through <i>f</i> . |
| 3 | Same as step 2 | Same as step 1 except: RANGE: 2 TUNING: 6 mc | Repeat step 1a through <i>f</i> at 6.0 mc on band 2 | Same as step 1a through <i>f</i> . |
| 4 | Same as step 1 except: <i>AN/URM-25A:</i> Main tuning dial: 12.0 mc FREQUENCY BAND switch: G | Same as step 1 except: RANGE: 2 TUNING: 12 mc | Repeat step 1a through <i>f</i> at 12.0 mc on band 2 | Same as step 1a through <i>f</i> . |
| 5 | Same as step 4 | Same as step 1 except: RANGE: 3 TUNING: 12 mc | Repeat step 1a through <i>f</i> at 12.0 mc on band 3 | Same as step 1a through <i>f</i> . |
| 6 | Same as step 1 except: ANI/URY-2SA FREQUENCY BAND switch: H Main dial: 24 mc | Same as step 1 except: RANGE: 3 TUNING: 24 mc | Repeat step 1a through <i>f</i> at 24.0 mc on band 3 | Same as step 1a through <i>f</i> . |

This page left blank intentionally.

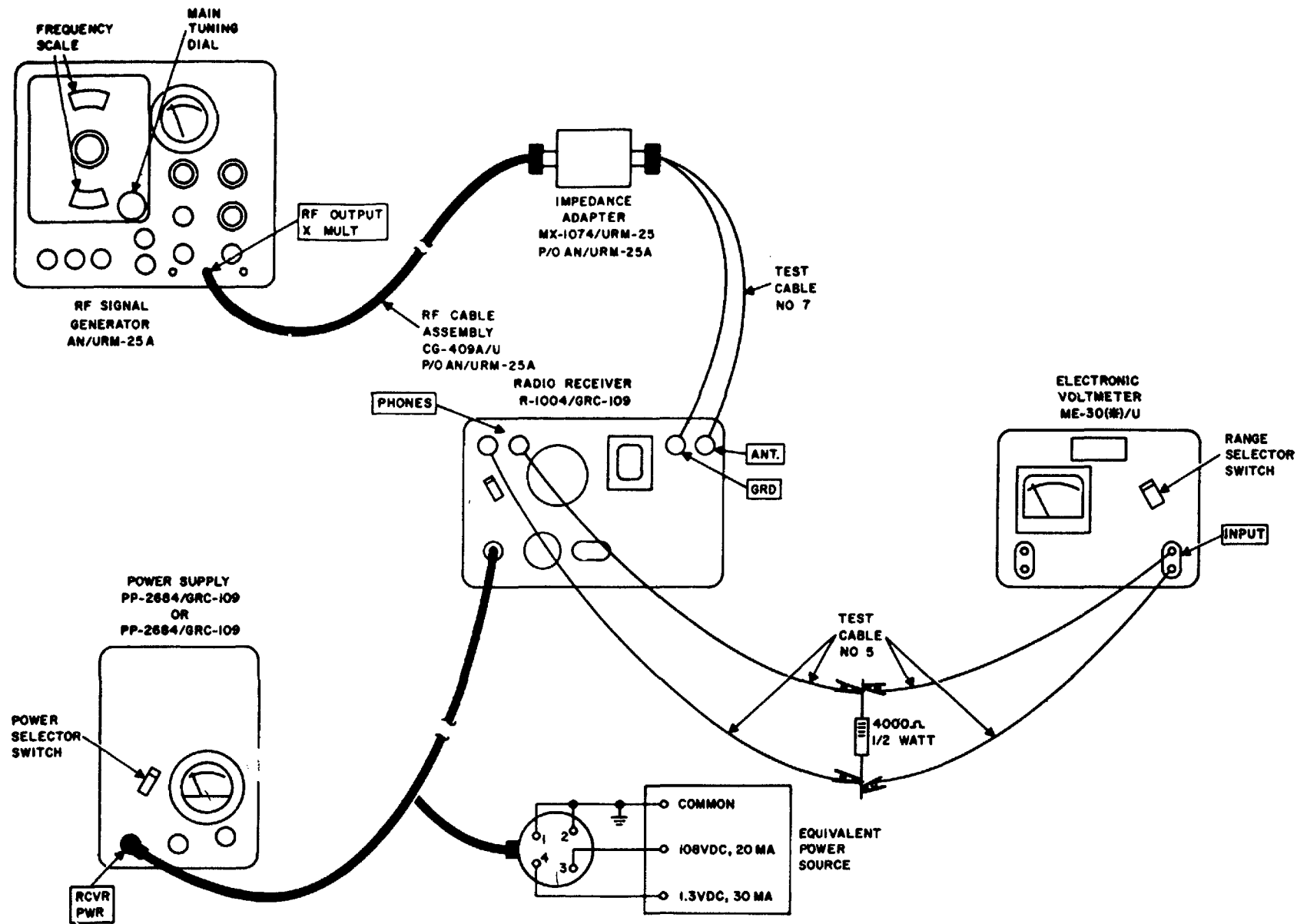

Figure 58. Receiver image rejection test.

105. Radio Receiver R-1004/GRC-109 Image Rejection Test*a. Test Equipment and Materials.*

R.F. Signal Generator Set AN/URM-25A
 Electronic Voltmeter ME-30(*)/U
 Power Supply PP-2685/GRC-109, PP-2684/GRC-109, or equivalent
 Resistor, 4,000 ohms, 1/2 watt
 Test cable No. 5 (4)
 Test cable No. 7

b. Test Connections and Conditions. Connect the equipment as shown in figure 58. Turn on all equipment and allow 15 minutes to warm up before proceeding.

c. Procedure.

| Step No. | Test equipment Control settings | Equipment under test control settings | Test procedure | Performance standard |
|----------|--|---|---|---|
| 1 | <i>PP-2685/GRC-109:</i> Power selector switch: 110 <i>AN/URM-25A:</i> FREQUENCY BAND switch: F CARRIER CONTROL: maximum counterclockwise. CARRIER RANGE switch: D Main tuning dial: 6 mc MULTIPLIER dial: 1000 % MODULATION control: maximum counterclockwise. MOD 8ELECTOR: 400 MICROVOLTS control: maximum counterclockwise. <i>ME-30(*)/U:</i> Range selector switch: 10V | <i>R-1004/GRC-109:</i> GAIN: 2/3 from MAX BEAT OSC: OFF RANGE: 1 TUNING: 6 mc | a. Adjust the output level of the AN/URM-25A to 10 microvolts, modulated 30%. b. Carefully adjust the main tuning dial on the AN/URM-25A for maximum indication on the ME-30(*)/U. c. Adjust the receiver GAIN control to obtain an indication of 4 volts on the ME-30(*)/U. d. Adjust the main tuning dial on the AN/URM-25A to 6.91 mc. e. Adjust the output level of the AN/URM-25A to approximately 100.000 microvolts. f. Carefully adjust main tuning dial on the AN/URM-25A for maximum indication on the ME-30(*)/U, and reduce the AN/URM-25A output level as necessary to keep the ME-30(*)/U meter on scale. g. When the ME-30(*)/U indication is maximum, adjust the output level of the AN/URM-25A to obtain an indication of 4 volts on the ME-30(*)/U. h. Note the output level on the AN/URM-25A | a. None. b. None. c. None. d. None. e. None. f. None. g. None. h. AN/URM-25A indication is 500 microvolts or higher. |
| 2 | Same as step 1 except: <i>AN/URM-25A:</i> Main tuning dial: 12.0 mc FREQUENCY BAND switch: G | Same as step 1 RANGE: 2 TUNING: 12 mc | Repeat step 1 a through b at a signal frequency of 12 mc and an image frequency of 12.91 mc. | Same as step 1 a through h |
| 3 | Same as step 1 except: <i>AN/URM-25A:</i> Main tuning dia: 24.0 mc FREQUENCY BAND switch: H | Same as step 1 RANGE: 3 TUNING: 24 mc | Repeat step 1 a through h at a signal frequency of 24 mc and an image frequency of 24.91 mc. | Same as step 1 a through h |

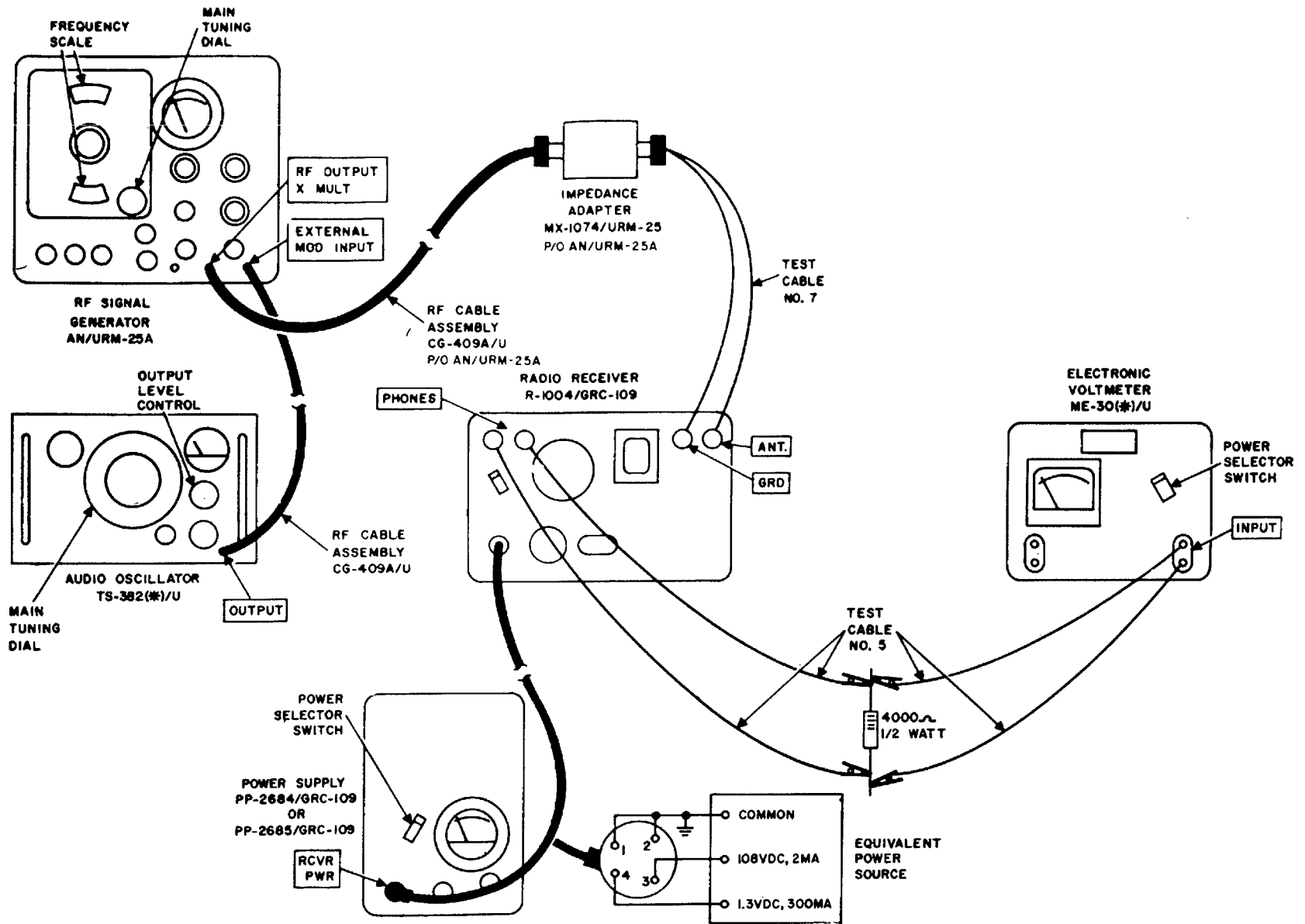

Figure 59. Receiver audio response test.

106. Radio Receiver R-1004/GRC-109 Audio Response Test

a. *Test Equipment and Materials.*

- R.F. Signal Generator Set AN/URM-25A
- Electronic Voltmeter ME-30(*)/U
- Power Supply PP-2685/GRC-109, PP-2684/GRC-109, or equivalent
- Audio Oscillator TS-382(*)/U
- Resistor, 4,000 ohms, 1/2 watt
- Test Cable No. 5 (4)
- Test Cable No. 7

b. *Test Connections and Conditions.* Connect the equipment as shown in figure 59. Turn on all equipment and allow a 15-minute warm up before proceeding.

c. *Procedure.*

| Step No. | Test equipment Control settings | Equipment under test control settings | Test procedure | Performance standard |
|----------|---|---|--|--|
| | <p><i>PP-2685/GRC-109:</i> Power selector switch: 110 <i>TS-382(*)/U:</i> Main tuning dial: 100 RANGE switch: X10 HEATER switch: OFF OSC switch: ON ATTENUATOR: 10 Output level control: maximum counterclockwise. FREQ METER switch: OFF <i>AN/URM-25SA:</i> FREQUENCY BAND SWITCH: F CARRIER CONTROL: maximum counterclockwise. CARRIER RANGE switch: F Main tuning dial: 3 mc MULTIPLIER dial: 1000 % MODULATION control: maximum counterclockwise. MOD SELECTOR: EXT MICROVOLTS control: maximum counterclockwise. XTAL CAL: OFF ME-30(*)/U: Range selector switch: +20 DB</p> | <p><i>R-104/GRC-109:</i> GAIN: 1/2 from MAX BEAT OSC: OFF RANGE: 1 TUNING: 3 mc</p> | <p>a. Adjust the output level control on the TS-382(*)/U to obtain an indication of approximately 4 volts on the output level meter. b. Adjust the output level of the AN/URM-25A to 10 microvolts, modulated 30%. c. Carefully adjust the main tuning dial on the AN/URM-25A for maximum indication on the ME -30(*)/U. d. Adjust the output level of the AN/URM-25A to obtain an indication of +13 db on the ME -30()/U. This is the 1,000-cycle reference level. e. Adjust the main tuning dial on the TS-382(*)/U to 30 f. Adjust the c MODULATION control on the AN/URM-25A to maintain 30n modulation. g. Note the indication on the ME-30(*)/U h. Adjust the main tuning dial on the TS-382(*)/U to 50 i. Adjust the % MODULATION control on the AN/URM-25A to maintain 30n modulation. j. Note the indication on the ME-30(*)/U k. Adjust the main tuning dial on the TS-382()/U to 80 l. Adjust the % MODULATION control on the AN/URM-25A to maintain 30% modulation. m. Note the indication on the ME-30(*)/U n. Adjust the main tuning dial on the TS-382(*)/U to 130 o. Adjust the % MODULATION control on the AN/URM-25A to maintain 30% modulation. p. Note the indication on the -ME-30(*)/U q. Adjust the main tuning dial on the TS-382(*)/U to 160 r. Adjust the % MODULATION control on the AN/URM-25A to maintain 30% modulation. s. Note the indication on the ME-30(*)/U t. Adjust the main tuning dial on the TS-382(*)/U to 30 u. Turn the RANGE switch on the TS-382()/U to X100 v. Adjust the % MODULATION control on the AN/URM-25A to maintain 30% modulation. w. Record the indication on the ME-30(*)/U</p> | <p>a. None. b. None. c. None. d. ME-30(*)/U indication is +13 db. e. None. f. None. g. ME-30(*)/U indication ms 13 db ± 3. h. None. i. None. j. ME-30()/U indication is 13 db ± 3. k. None. l. None. m. ME-30(*)/U indication is 13 db ±3. n. None. o. None. p. ME-30(*)/U indication is 13 db ± 3. q. None. r. None. s. ME-30(*)/U indication is 13 db ± 4.5. t. None. l None. v. None. w. ME-30(*)/U is less than +3 db.</p> |

107. Summary of Test Data

Personnel may find it convenient to arrange the checklist in a manner similar to that shown below.

a. POWER SUPPLY PP-2684/GRC-109

| | Test Data | Output Voltage Performance Standard | Test Data | Ripple Voltage Performance Standard |
|---|-----------|-------------------------------------|-----------|-------------------------------------|
| (1) TRANSMITTER B+ OUTPUT VOLTAGE AND RIPPLE | | | | |
| 220 volts ac input | _____ | 450 ±25 | _____ | 5 volts max |
| 75 volts ac input | _____ | 450 ±25 | _____ | 5 volts max |
| 110 volts ac input | _____ | 450 ±25 | _____ | 5 volts max |
| 6 volts ac input | _____ | 450 ±25 | | |
| hand-cranked generator input | _____ | 450 ±25 | | |
| (2) RECEIVER B+ OUTPUT VOLTAGE AND RIPPLE | | | | |
| 220 volts ac input | _____ | 100 ±10 | _____ | 0.04 volts max |
| 75 volts ac input | _____ | 100 ±10 | _____ | 0.04 volts max |
| 110 volts ac input | _____ | 100 ±10 | _____ | 0.04 volts max |
| (3) RECEIVER FILAMENT OUTPUT VOLTAGE AND RIPPLE | | | | |
| 220 volts ac input | _____ | 1.35 ±0.1 | _____ | 0.04 volts max |
| 75 volts ac input | _____ | 1.35 ±0.1 | _____ | 0.04 volts max |
| 110 volts ac input | _____ | 1.35 ±0.1 | _____ | 0.04 volts max |
| (4) TRANSMITTER FILAMENT OUTPUT VOLTAGE | | | | |
| 220 volts ac input | _____ | 6.3 ±0.4 | | |
| 75 volts ac input | _____ | 6.3 ±0.4 | | |
| 110 volts ac input | _____ | 6.3 ±0.4 | | |

b. POWER SUPPLY PP-2685/GRC-109

| | Test Data | Output Voltage Performance Standard | Test Data | Ripple Voltage Performance Standard |
|--|-----------|-------------------------------------|-----------|-------------------------------------|
| (1) TRANSMITTER B+ OUTPUT VOLTAGE AND RIPPLE | | | | |
| 220 volts ac input | _____ | 450 ±25 | _____ | 10 volts max |
| 75 volts ac input | _____ | 450 ±25 | _____ | 10 volts max |
| 110 volts ac input | _____ | 450 ±25 | _____ | 10 volts max |

| | Test Data | Output Voltage Performance Standard | Test Data | Ripple Voltage Performance Standard |
|---|-----------|-------------------------------------|-----------|-------------------------------------|
| (2) RECEIVER B+ OUTPUT VOLTAGE AND RIPPLE | | | | |
| 220 volts ac input | _____ | 100 ±10 | _____ | 0.04 volts max |
| 75 volts ac input | _____ | 100 ±10 | _____ | 0.04 volts max |
| 110 volts ac input | _____ | 100 ±10 | _____ | 0.04 volts max |
| (3) RECEIVER FILAMENT OUTPUT VOLTAGE AND RIPPLE | | | | |
| 220 volts ac input | _____ | 1.35 ±0.1 | _____ | 0.04 volts max |
| 75 volts ac input | _____ | 1.35 ±0.1 | _____ | 0.04 volts max |
| 110 volts ac input | _____ | 1.35 ±0.1 | _____ | 0.04 volts max |
| (4) TRANSMITTER FILAMENT OUTPUT VOLTAGE | | | | |
| 220 volts ac input | _____ | 6.3 ±0.4 | | |
| 75 volts ac input | _____ | 6.3 ±0.4 | | |
| 110 volts ac input | _____ | 6.3 ±0.4 | | |

c. RADIO TRANSMITTER T-784/GRC-109

| | Test Data | Performance Standard |
|---------------------|-----------|----------------------|
| <i>POWER OUTPUT</i> | | |
| 3. 0 mc, band 1 | _____ | 10 watts min |
| 5. 5 mc, band 1 | _____ | 5 watts min |
| 5. 5 mc, band 2 | _____ | 10 watts min |
| 9. 0 mc, band 2 | _____ | 10 watts min |
| 9. 0 mc, band 3 | _____ | 10 watts min |
| 16. 0 mc, band 3 | _____ | 10 watts min |
| 16. 0 mc, band 4 | _____ | 10 watts min |
| 22. 0 mc, band 4 | _____ | 10 watts min |

This page intentionally left blank.

CHAPTER 10

SHIPMENT AND LIMITED STORAGE AND
DEMOLITION TO PREVENT ENEMY USE

Section I. SHIPMENT AND LIMITED STORAGE

108. Disassembly of Equipment

Disassemble the radio set as follows:

- a. Operate the power selector switch on the power supply to OFF.
- b. Disconnect the power supply from the power source.
- c. Disconnect the antenna and ground wire systems from the transmitter and receiver. Disassemble the antenna and ground systems and rewind the wires on their respective storage spools.
- d. Disconnect all interunit connecting cables. Place the transmitter and receiver cables in the cable supports on the front panels. Coil the power supply cable and place it on the power supply front panel.
- e. Replace the sealing gaskets, top covers, and mounting screws on each of the units.

109. Repacking for Shipment or Limited Storage

Repacking of equipment for shipment or limited storage normally will be performed at a packaging facility or by a packaging team. Should emergency packaging be required, select materials from those listed in SB 11-100. Package the equipment in accordance with the original packaging insofar as possible with available materials.

110. Handling, Storage, and Disposal of Radioactive Material

Follow the procedures for safe handling, storage, and disposal of radioactive materials as directed by:

- a. TB SIG 225, Identification and Handling of Radioactive Signal Items.
- b. AR 700-52, Licensing and Control of Radioactive Materials.
- c. AR 755-380, Disposal of Unwanted Radioactive Material.

Section II. DEMOLITION OF MATERIEL TO PREVENT ENEMY USE

111. Authority for Demolition

Demolition of the equipment will be accomplished only upon order of the commander. The destruction procedures outlined in paragraph 112 will be used to prevent further use of the equipment.

112. Methods of Destruction

Use any of the following methods to destroy the equipment:

- a. *Smash.* Smash the controls, tubes, coils, switches, capacitors, transformers, and meters; use sledges, axes, handaxes, pickaxes, hammers, or crowbars.
- b. *Cut.* Cut the output and power cord and slash the rf shield; use axes, handaxes, or machetes.

Warning; Be extremely careful in the use of explosives and incendiary devices. These items should not be used unless extreme urgency demands their use.

- c. *Burn.* Burn cords and technical manuals; use gasoline, kerosene, oil, flamethrowers, or incendiary grenades.
- d. *Bend.* Bend panel and cabinet.
- e. *Explode.* If explosives are necessary, use firearms, grenades, or TNT.
- f. *Dispose.* Bury or scatter the destroyed parts in slit trenches, foxholes, or throw them into streams.

APPENDIX I
REFERENCES

Following is a list of references applicable and available for Radio Set AN/GRC-109.

| | |
|---------------------|---|
| DA Pam 310-4 | Index of Technical Manuals, Technical Bulletins, Supply Manuals (Types 7, 8, and 9), Supply Bulletins and Lubrication Orders. |
| DA Pam 310-7 | US Army Index of Modification Work Orders. |
| SM 11-4-5180-R09 | Radio Repair Tool Kit TK-115/G. |
| TM 11-5094 | Frequency Meter AN/URM-79. |
| TM 11-5095 | Frequency Meter AN/URM-80. |
| TM 11-5120 | Frequency Meters AN/URM-32 and AN/URM-32A and Power Supply PP1243/U. |
| TM 11-5122 | Direct Current Generator G-43/G. |
| TM 11-5129 | Oscilloscopes AN/USM-50A, B, and C. |
| TM 11-5551B | R.F. Signal Generator Set AN/URM-25B. |
| | Operator's, Organizational, Direct Support and General Support Maintenance Repair Parts and Special Tools Lists (Including Depot Maintenance Repair Parts and Special Tools): Transformer, Variable, Power CN-16/U, CN16A/U, and CN-16B/U. |
| TM 11-6625-320-12 | Operator's and Organizational Maintenance Manual: Voltmeter, Meter ME30A/U and Voltmeters, Electronic ME-30B/U, ME-30C/U, and ME-30E./U. |
| TM 11-6625-366-15 | Operator's, Organizational, DS, GS, and Depot Maintenance Manual: Multimeter TS-352B/U. |
| TM 11-6625-446-15 | Operator's, Organizational, DS, GS, and Depot Maintenance Manual: Wattmeter AN/URM-120. |
| TM 11-6625-486-14&P | Operator's, Organizational Direct Support, and General Support Maintenance Manual Including Repair Parts and Special Tools Lists (Including Depot Maintenance Repair Parts and Special Tools) for Frequency Meters AN/ USM-159, AN/USM-159A, and AN/USM-159B. |
| TM 38-750 | The Army Maintenance Management System (TAMMS). |
| TM 43-0139 | Painting Instructions for Field Use. |

| | |
|--------------------|--|
| TM 740-90-1 | Administrative Storage of Equipment. |
| TM 750-244-2 | Procedures for Destruction of Electronics Materiel to Prevent Enemy Use (Electronics Command). |
| TM 11-6625-200-15 | Operator's, Organizational, DS, GS, and Depot Maintenance Manual: Multimeters ME-26A/U, ME-26B/U, ME-26C/U and ME-26D/U. |
| TM 11-6625-200-24P | Organizational, Direct Support, and General Support Maintenance Repair Parts and Special Tools Lists (Including Depot Maintenance Repair Parts and Special Tools): Multimeters ME-26A/U, ME-26B/U, ME-26C/U, and ME-26D/U. |
| TM 11-6625-261-12 | Operator's and Organizational Maintenance Manual: Audio Oscillators TS382A/U, TS-382B/U, TS-382D/U, TS-382E/U, and TS-382F/U. |
| TM 11-6625-274-12 | Operator's and Organizational Maintenance Manual: Test Sets, Electron Tube TV-7/U, TV-7A/U, TV-7B/U, and TV-7D/U. |
| TM 11-6625-300-20P | Organizational Maintenance Repair Parts and Special Tools Lists: Frequency Meter AN/URM-79. |

APPENDIX II

**BASIC ISSUE ITEMS LIST (BIIL) AND ITEMS TROOP
INSTALLED OR AUTHORIZED LIST (ITIAL)**

Section I. INTRODUCTION

1. Scope

This appendix lists basic issue items and items troop installed or authorized required by the crew/operator for installation, operation, and maintenance of Radio Set AN/GRC-109.

2. General

This Basic Issue Items and Items Troop Installed or Authorized List is divided into the following sections:

a. Basic Issue Items List - Section II. A list, in alphabetical sequence, of items which are furnished with, and which must be turned in with the end item.

b. Items Troop Installed or Authorized List Section III. A list, in alphabetical sequence, of items which, at the discretion of the unit commander, may accompany the end item, but are not subject to be turned in with the end item.

3. Explanation of Columns

The following provides an explanation of columns found in the tabular listings:

a. Illustration. This column is divided as follows:

(1) *Figure Number.* Indicates the figure number of the illustration in which the item is shown.

(2) *Number.* Not applicable.

b. Federal Stock Number. Indicates the Federal stock number assigned to the item and will be used for requisitioning purposes.

c. Part Number. Indicates the primary number used by the manufacturer (individual, company, firm, corporation, or government activity), which controls the design and characteristics of the item by means of its engineering drawings, specifications standards, and inspection requirements, to identify an item or range of items.

d. Federal Supply Code for Manufacturer (FSCM). The FSCM is a 5-digit numeric code used to identify the manufacturer, distributor, or Government agency, etc., and is identified in SB 708-42.

e. Description. Indicates the Federal item name and a minimum description required to identify the item.

f. Unit of Measure (U/M). Indicates the standard of basic quantity of the listed item as used in performing the actual maintenance function. This measure is expressed by a two-character alphabetical abbreviation, (e.g., ea, in, pr, etc. When the unit of measure differs from the unit of issue, the lowest unit of issue that will satisfy the required units of measure will be requisitioned.

g. Quantity Furnished with Equipment (Basic Issue Items Only). Indicates the quantity of the basic issue item furnished with the equipment.

h. Quantity Authorized (Items Troop Installed or Authorized Only). Indicates the quantity of the item authorized to be used with the equipment.

Section II. BASIC ISSUE ITEMS LIST

| (1) Illustration | | (2) Federal stock number | (3) Part number | (4) FSCM | (5) Description Usable on code | (6) Unit of meas | (7) Qty furn with equip |
|---------------------|--------------------|-----------------------------------|-----------------------|-------------|--|---------------------------|-------------------------------------|
| (A) Fig. no. | (B) Item no. | | | | | | |
| 3 | | 5820-863-3500 | | | CASE, ELECTRONIC EQUIPMENT MAIN- TENANCE KIT CY- 4621/GRC-109 | EA | 1 |

Section III. ITEMS TROOP INSTALLED OR AUTHORIZED LIST

| (1) Federal stock number | (2) Part number | (3) FSCM | (4) Description Usable on code | (5) Unit of meas | (6) Qty auth |
|-----------------------------------|-----------------------|-------------|---|---------------------------|--------------------|
| 7340-240-5943 | | | KNIFE TL-29 | EA | 1 |
| 5120-856-3735 | 53-6 | 07885 | PLIERS | EA | 1 |
| 5120-897-2036 | CrI | XceLite | SCREWDRIVER | EA | 1 |
| 5120-856-1958 | A11534 | 99799 | WRENCH: OPEN END | EA | 1 |
| 5120-608-0116 | | | WRENCH: ALLEN NO. 8 | EA | 1 |

Next printed page is 117.

Change 5 114

APPENDIX III

MAINTENANCE ALLOCATION

Section I. INTRODUCTION

A3-1. General

This appendix provides a summary of the maintenance operations for AN/GRC-109. It authorizes categories of maintenance for specific maintenance functions on repairable items and components and the tools and equipment required to perform each function. This appendix may be used as an aid in planning maintenance operations.

A3-2. Maintenance Function

Maintenance functions will be limited to and defined as follows:

a. Inspect. To determine the serviceability of an item by comparing its physical, mechanical, and/or electrical characteristics with established standards through examination.

b. Test. To verify serviceability and to detect incipient failure by measuring the mechanical or electrical characteristics of an item and comparing those characteristics with prescribed standards.

c. Service. Operations required periodically to keep an item in proper operating condition, i.e., to clean (decontaminate), to preserve, to drain, to paint, or to replenish fuel, lubricants, hydraulic fluids, or compressed air supplies.

d. Adjust. To maintain, within prescribed limits, by bringing into proper or exact position, or by setting the operating characteristics to the specified parameters.

e. Align. To adjust specified variable elements of an item to bring about optimum or desired performance.

f. Calibrate. To determine and cause corrections to be made or to be adjusted on instruments or test measuring and diagnostic equipments used in precision measurement. Consists of comparisons of two instruments, one of which is a certified standard of known accuracy, to detect and adjust any discrepancy in the accuracy of the instrument being compared.

g. Install. The act of emplacing, seating, or fixing into position an item, part, module (component or

assembly) in a manner to allow the proper functioning of the equipment or system.

h. Replace. The act of substituting a serviceable like type part, subassembly, or module (component or assembly) for an unserviceable counterpart.

i. Repair. The application of maintenance services (inspect, test, service, adjust, align, calibrate, replace) or other maintenance actions (welding, grinding, riveting, straightening, facing, remachining, or resurfacing) to restore serviceability to an item by correcting specific damage, fault, malfunction, or failure in a part, subassembly, module (component or assembly), end item, or system.

j. Overhaul. That maintenance effort (service/action) necessary to restore an item to a completely serviceable/operational condition as prescribed by maintenance standards (i.e., DMWR) in appropriate technical publications. Overhaul is normally the highest degree of maintenance performed by the Army. Overhaul does not normally return an item to like new condition.

k. Rebuild. Consists of those services/actions necessary for the restoration of unserviceable equipment to a like new condition in accordance with original manufacturing standards. Rebuild is the highest degree of materiel maintenance applied to Army equipment. The rebuild' operation includes the act of returning to zero those age measurements (hours, miles, etc.) considered in classifying Army equipments/components.

A3-3. Column Entries

a. Column 1, Group Number. Column 1 lists group numbers, the purpose of which is to identify components, assemblies, subassemblies, and modules with the next higher assembly.

b. Column 2, Component/Assembly. Column 2 contains the noun names of components, assemblies,

and modules for which maintenance is authorized.

c. *Column 3, Maintenance Functions.* Column 3 lists the functions to be performed on the item listed in column 2. When items are listed without maintenance functions, it is solely for purpose of having the group numbers in the MAC and RPSTL coincide.

d. *Column 4, Maintenance Category.* Column 4 specifies, by the listing of a "worktime" figure in the appropriate subcolumn(s), the lowest level of maintenance authorized to perform the function listed in column 3. This figure represents the active time required to perform that maintenance function at the indicated category of maintenance. If the number or complexity of the tasks within the listed maintenance function vary at different maintenance categories, appropriate "worktime" figures will be shown for each category. The number of task-hours specified by the "worktime" figure represents the average time required to restore an item (assembly, subassembly, component, module, end item or system) to a serviceable condition under typical field operating conditions. This time includes preparation time, troubleshooting time, and quality assurance/quality control time in addition to the time required to, perform the specific tasks identified for the maintenance functions authorized in the maintenance allocation chart. Subcolumns of column 4 are as follows:

- C--Operator/Crew
- O--Organizational
- F--Direct Support
- H--General Support
- D--Depot

e. *Column 5, Tools and Equipment.* Column 5 specifies by code, those common tool sets (not

individual tools) and special tools, test, and support equipment required to perform the designated function.

f. *Column 6, Remarks.* Column 6 contains an alphabetic code which leads to the remark in section IV, Remarks, which is pertinent to the item opposite the particular code.

A3-4. Tool and Test Equipment Requirements (sec III)

a. *Tool or Test Equipment Reference Code.* The numbers in this column coincide with the numbers used in the tools and equipment column of the MAC. The numbers indicate the applicable tool or test equipment for the maintenance functions.

b. *Maintenance Category.* The codes in this column indicate the maintenance category allocated the tool or test equipment.

c. *Nomenclature.* This column lists the noun name and nomenclature of the tools and test equipment required to perform the maintenance functions.

d. *National/NATO Stock Number.* This column lists the National/NATO stock number of the specific tool or test equipment.

e. *Tool Number.* This column lists the manufacturer's part number of the tool followed by the Federal Supply Code for manufacturers (5-digit) in parentheses.

A3-5. Remarks (sec IV)

a. *Reference Code.* This code refers to the appropriate item in section II, column 6.

b. *Remarks.* This column provides the required explanatory information necessary to clarify items appearing in section II.

(Next printed page is 119.)

| (1) GROUP NUMBER | (2) COMPONENT/ ASSEMBLY | (3) MAINT. FUNCTION | (4) MAINTENANCE CATEGORY | | | | | (5) TOOLS AND EQUIP | (6) REMARKS |
|------------------------|---|------------------------------------|-----------------------------|----------------------|-------------------|---|------|---------------------------------|----------------|
| | | | C | O | F | H | D | | |
| | | | | | | | | | |
| 00 | RADIO SET AN/GRC-109 | Service Inspect Test Test | | 0.25 0.25 0.25 | | | | 1,2,3 2,4 thru 11 | A |
| | | Align Repair Repair | | | 0.5 0.5 1.5 | | | 6,7,11 1,3 2,4 thru 11 | D |
| 01 | RADIO TRANSMITTER T-784/GRC-109 | Replace Test Test | | 0.25, 0.25 | | | 0.25 | 2,4,11 2,4,10, 11 | B |
| | | Repair Repair | | | 0.75 0.75 | | 0.75 | 2,4,11 2,4,10, 11 | B |
| 02 | RADIO RECEIVER R-1004/GRC-109 | Replace Test | | 0.25 | | | 0.25 | 24.,6,8, 9,11 | B |
| | | Test | | | | | 0.25 | 2,4 thru 9,11 | |
| | | Align Repair Repair | | 0.5 | | | 0.25 | 6,7,11 1,2,3 2,4 thru | D B |
| | | Repair | | | | | 0.75 | 6,8,9,11 2,4 thru 9,11 | |
| 0201 | IF AND AUDIO CHASSIS (LISTED FOR REFERENCE ONLY) TESTED AS PART OF NEXT HIGHER ASSEMBLY | | | | | | | | |
| 0202 | RF CHASSIS (LISTED FOR REFERENCE ONLY) TESTED AS PART OF NEXT HIGHER ASSEMBLY | | | | | | | | |
| 0203 | BFO OSCILLATOR (LISTED FOR REFERENCE ONLY) TESTED AS PART OF NEXT HIGHER ASSEMBLY | | | | | | | | |
| 03 | POWER SUPPLY PP-2684/GRC-109 | Replace Test Test | | 0.25 | 0.25 | | 0.5 | 4,11 4,5,7,8, 11 | C |
| | | Repair Repair | | 0.25 | 0.5 | | | 1,2,3 4,11 | D |
| 04 | POWER SUPPLY PP-2685/GRC-109 SAME MAINTENANCE AS 03 | | | | | | | | |
| 05 | REGULATOR, VOLTAGE CN-690/GRC-109 | Test Replace Repair | | 0-25 | 0.25 0.5 | | | 4,11 1 4,11 | |

**SECTION III TOOL AND TEST EQUIPMENT REQUIREMENTS
FOR
RADIO SET AN/GRC-109**

| TOOL OR TEST EQUIPMENT REF CODE | MAINTENANCE CATEGORY | NOMENCLATURE | NATIONAL/NATO STOCK NUMBER | TOOL NUMBER |
|---------------------------------|----------------------|---|----------------------------|-------------|
| 1 | O | MULTIMETER AN/URM-105B | 6625-00-884-1758 | |
| 2 | O,F,H | TEST SET, ELECTRONIC TUBE TV-7D | 6625-00-820-0064 | |
| 3 | O | TOOL KIT ELECTRONIC EQUIPMENT TK-101/G | 5180-00-064-5178 | |
| 4 | F,H | MULTIMETER TS-352B/U | 6625-00-553-0142 | |
| 5 | F,H | MULTIMETER ME-26B/U | 6625-00-646-9409 | |
| 6 | F,H | RF SIGNAL GENERATOR SET AN/URM-25 | 6625-00-649-5193 | |
| 7 | F,H | VOLTMETER, ELECTRONIC ME-30/U | 6625-00-643-1670 | |
| 8 | F,H | VARIABLE POWER TRANSFORMER CN-16/U | 5950-00-235-2085 | |
| 9 | F,H | AUDIO OSCILLATOR AN/URM-127 | 6625-00-783-5965 | |
| 10 | F,H | WATTMETER AN/URM-120 | 6625-00-813-8430 | |
| 11 | F,H | TOOL KIT, ELECTRONIC EQUIPMENT TK-105/G | 5180-00-610-8177 | |

SECTION IV. REMARKS

| REFERENCE CODE | REMARKS |
|-------------------|---------------------------------------|
| A | OPERATIONAL TEST |
| B | ALL EXCEPT RF STAGES |
| C | EXCEPT OUTPUT VOLTAGE AND RIPPLE TEST |
| D | BY AUTHORIZED PARTS REPLACEMENT |

Next printed page is 135.

Change 6 121

INDEX

| | Paragraph | Page | | Paragraph | Page |
|--|-----------|--------|---|-----------|--------|
| Ac lines operation | 15a, | 55 | Localizing troubles: | | |
| Additional equipment required | 10 | 10 | Power Supply PP-2684/GRC-109 | 79 | 64 |
| Alignment | 19 | 20 | Power Supply PP-2685/GRC-109 | 83 | 69 |
| Antenna system | 8e, 13b, | 14 | Radio Receiver R-1004/GRC-109 | 66 | 46 |
| AntiJamming procedures..... | 25 | 22 | Radio Transmitter T-784/GRC-109 | 73 | 57 |
| Audio amplifier..... | 52 | 38 | Lubrication | 38 | 31 |
| Audio response test..... | 106 | 103 | Maintenance: | | |
| Battery charging operation..... | 8d, | 58 | Operator's | 30 | 24 |
| Beat frequency oscillator: | | | Preventive | 31,37 | 24,31 |
| Alignment | 92 | 77 | Second echelon | 35 | 31 |
| Theory | 53 | 38 | Nomenclature and common name | 6 | 5 |
| Block diagram: | | | Operating accessories | 5b | 5 |
| Power Supply PP-2684/GRC-109..... | 54 | 39 | Operating precautions..... | 23 | 22 |
| Power Supply PP-2685/GRC-109..... | 59 | 42 | Operating procedures | 22 | 22 |
| Radio Receiver R-1004/GRC- 109..... | 47 | 36 | Operational checklist..... | 33 | 25 |
| Radio Transmitter T-784/GRC-109..... | 42 | 34 | Operator's maintenance | 30 | 24 |
| Checking filaments and B+ for shorts: | | | Oscillator: | | |
| Power Supply PP-2684/GRC-109 | 77 | 63 | Radio Receiver R-1004/GRC-109 | 49c, d | 37 |
| Power Supply PP-2685/GRC-109 | 81 | 69 | Radio Transmitter T-784/GRC-9 | 43 | 34 |
| Radio Receiver R-1004/GRC-109 | 64 | 45 | Output voltage and ripple tests: | | |
| Radio Transmitter T-784/GRC-109 | 71 | 56 | Power supply PP-2684/GRC-109 | 100 | 83 |
| Checking unpacked equipment | 12 | 11 | Power supply PP-2685/GRC-109 | 101 | 87 |
| Controls and indicators..... | 17 | 17 | Physical tests and inspection: | | |
| Converter | 49 | 37 | Power Supply PP-2684/GRC-109 | 96 | 80 |
| Counterpoise grounding | 14c(1) | 15 | Power Supply PP-2685/GRC-109 | 97 | 80 |
| Damage from improper settings | 16 | 17 | Radio Receiver R-1004/GRC-109 | 99 | 81 |
| Description and data..... | 3 | 3 | Radio Transmitter T-784/GRC-109 | 98 | 81 |
| Detector..... | 53 | 38 | Power amplifier | 44 | 35 |
| Extension cord, description | 9c | 10 | Power cable, description | 9b | 10 |
| Forms and records | 2 | 3 | Power output test | 102 | 91 |
| Fourth echelon testing procedures | 93 | 78 | Power Supply PP-2684/GRC-109: | | |
| Test equipment required | 94 | 78 | Ac lines operation | 55 | 40 |
| Grounding system | 14c | 15 | Battery charging operation | 8d, 58 | 10,42 |
| Hand-cranked generator operation | 15c, d,57 | 16; 41 | Block diagram | 54 | 39 |
| If. amplifier: | | | Checking filament and B+ for shorts..... | 77 | 63 |
| Alignment | 90 | 76 | Circuit analysis..... | 60 | 42 |
| Theory | 50,51 | 37,38 | Dc resistance of coils and transformers | 80 | 65 |
| If. bandwidth test | 103 | 95 | Description..... | 80 | 10 |
| Image rejection test | 105 | 101 | Hand-cranked generator operation..... | 150c, 57 | 16,41 |
| Installation, Radio Set AN/GRC 109 | 14 | 13 | Localizing troubles | 79 | 64 |
| Jamming, recognition and identification..... | 24 | 22 | Output voltage and ripple tests | 100 | 83 |
| Keying | 46 | 35 | Physical tests and Inspection | 96 | 80 |
| | | | Reference designation changes..... | 76 | 63 |
| | | | Repairs | 87a | 75 |
| | | | Storage battery operation | 15b, 56 | 16, 41 |
| | | | Technical characteristics..... | 4c | 4 |
| | | | Test setup..... | 78 | 63 |
| | | | Troubleshooting chart | 79d | 64 |
| | | | Power Supply PP-2685/GRC-109: | | |
| | | | Block diagram | 59 | 42 |
| | | | Checking filaments and B+ for shorts..... | 81 | 69 |
| | | | Circuit analysis..... | 60 | 42 |
| | | | Dc resistance of coils and transformers | 84 | 70 |
| | | | Description..... | 8d | 10 |

| | Paragraph | Page | | Paragraph | Page |
|---|-------------|------------|---|-----------|--------|
| Localizing troubles..... | 83 | 69 | Radio Transmitter T-7b4/GRC-109: | | |
| Output voltage and ripple tests..... | 101 | 87 | Block diagram | 42 | 34 |
| Physical tests and inspection..... | 97 | 80 | Checking filaments and B+ for shorts..... | 71 | 56 |
| Repairs..... | 87b | 75 | Controls and indicators..... | 17 | 17 |
| Technical characteristics | 4d | 4 | Dc resistances of coils and transformers... | 75 | 57 |
| Test setup | 82 | 69 | Description..... | 8a | 6 |
| Troubleshooting chart | 83d | 69 | Isolating trouble within a stage..... | 74 | 57 |
| Preliminary starting procedures..... | 18 | 20 | Keying | 46 | 35 |
| Preventive maintenance..... | 31, 37 | 24, 31 | Localizing troubles | 73 | 57 |
| Purpose and use | 3 | 3 | Oscillator..... | 43 | 4 |
| Radio Receiver R-1004/GRC-109: | | | Physical tests and inspection..... | 98 | 81 |
| Af amplifier..... | 52 | 38 | Power amplifier | 44 | 35 |
| Alignment | 89 | 76 | Power output test | 102 | 91 |
| Antenna circuit | 45 | 35 | Reference designation changes..... | 70 | 56 |
| Audio response test | 106 | 103 | Technical characteristics..... | 4a | 3 |
| Beat frequency oscillator | 53 | 38 | Test setup..... | 72 | 56 |
| Block diagram | 47 | 36 | Troubleshooting chart | 73d | 57 |
| Checking filament and B+ for shorts..... | 64 | 45 | Tuning procedure..... | 20 | 21 |
| Controls and indicators | 17 | 17 | Reference designation changes: | | |
| Converter..... | 49 | 37 | Power Supply PP-2684/GRC-109 | 76 | 63 |
| Dc resistance of coils and transformers..... | 69 | 56 | Radio Transmitter T-784/GRC-109 | 70 | 56 |
| Description | 8b | 10 | Repairs and adjustment | 34, 87 | 26, 75 |
| Detector..... | 52 | 38 | Resistances of coils and transformers: | | |
| If. amplifier | 50, 51 | 37, 38 | Power Supply PP-2684/GRC-109 | 80 | 65 |
| If. bandwidth test..... | 103 | 95 | Power Supply PP-2685/GRC-109 | 84 | 70 |
| Image rejection test..... | 105 | 101 | Radio Receiver R-1004/GRC-109 | 69 | 56 |
| Isolating trouble within a stage | 68 | 54 | Radio Transmitter T-784/GRC-109 | 75 | 57 |
| Localizing troubles..... | 66 | 46 | Rf amplifier | 48 | 36 |
| Physical tests and inspection..... | 99 | 81 | Scope of manual | 1 | 3 |
| Rf amplifier..... | 48 | 36 | Second echelon maintenance | 35 | 31 |
| Signal substitution..... | 67 | 53 | Signal substitution..... | 67 | 53 |
| Signal-to-noise ratio test..... | 104 | 97 | Signal-to-noise ratio test..... | 104 | 97 |
| Technical characteristics | 4b | 4 | Siting | 13 | 11 |
| Test equipment required for alignment..... | 88 | 75 | Spares | 5c | 5 |
| Test setup | 65 | 46 | Special test leads..... | 95 | 18 |
| Troubleshooting chart | 66d | 46 | Starting procedure, power supplies..... | 19 | 20 |
| Tuning procedure..... | 21 | 21 | Starting procedure, preliminary..... | 18 | 20 |
| Radio Set AN/GRC-109: | | | Stopping procedure..... | 21 | 21 |
| Alignment | 87 | 75 | Storage battery operation | 19b, 56 | 21, 41 |
| Antenna system | 8e, 13b, 14 | 10, 13, 13 | Summary of test data | 107 | 105 |
| Checking filament and B+ circuits for shorts | 64 | 45 | Technical characteristics: | | |
| Components..... | 5 | 4 | Power Supply PP-2684/GRC-109 | 4c | 4 |
| Description | 7 | 5 | Power Supply PP-2685/GRC-109 | 4d | 4 |
| Grounding system..... | 14c | 15 | Radio Receiver R-1004/GRC-109 | 4b | 4 |
| Operating accessories | 5b | 5 | Radio Transmitter T-784/GRC-109 | 4a | 3 |
| Purpose and use | 3 | 3 | Test data, summary | 107 | 105 |
| Relationship between units..... | 41 | 34 | Test setup: | | |
| Repairs..... | 87 | 75 | Power Supply PP2684/GRC-109 | 78 | 63 |
| Siting..... | 13 | 11 | Power Supply PP-2685/GRC-109 | 82 | 69 |
| Spares | 5c | 5 | Radio Receiver R-1004/GRC-109 | 65 | 46 |
| Technical characteristics | 4 | 3 | Radio Transmitter T-784/GRC-109 | 72 | 56 |
| Test equipment required | 63 | 45 | Troubleshooting: | | |
| Unit interconnections | 15 | 15 | General instruction..... | 61 | 44 |
| | | | Procedures | 62 | 44 |
| | | | Second echelon | 39 | 31 |

| | Paragraph | Page |
|---------------------------------------|-----------|------|
| Voltage Regulator CN-690/GRC-109..... | 86 | 73 |
| Troubleshooting chart: | | |
| Power Supply PP-2684/GRC-/109..... | 79d | 64 |
| Power Supply PP-2685/GRC-109..... | 83d | 69 |
| Radio Receiver R-1004/GRC-109..... | 66d | 46 |
| Radio Transmitter T-784/GRC-109..... | 73d | 57 |
| Tube testing | 40 | 31 |

| | Paragraph | Page |
|---------------------------------------|-----------|------|
| Tuning procedure: | | |
| Radio Receiver R-1004/GRC-109 | 21 | 21 |
| Radio Transmitter T-784/GRC-109 | 20 | 21 |
| Unit interconnections | 15 | 15 |
| Unpacking | 11 | 11 |
| Visual inspection..... | 32 | 24 |
| Voltage Regulator CN-690/GRC-109: | | |
| Description..... | 9a | 10 |
| Troubleshooting..... | 85, 86 | 73 |

This page left blank intentionally.

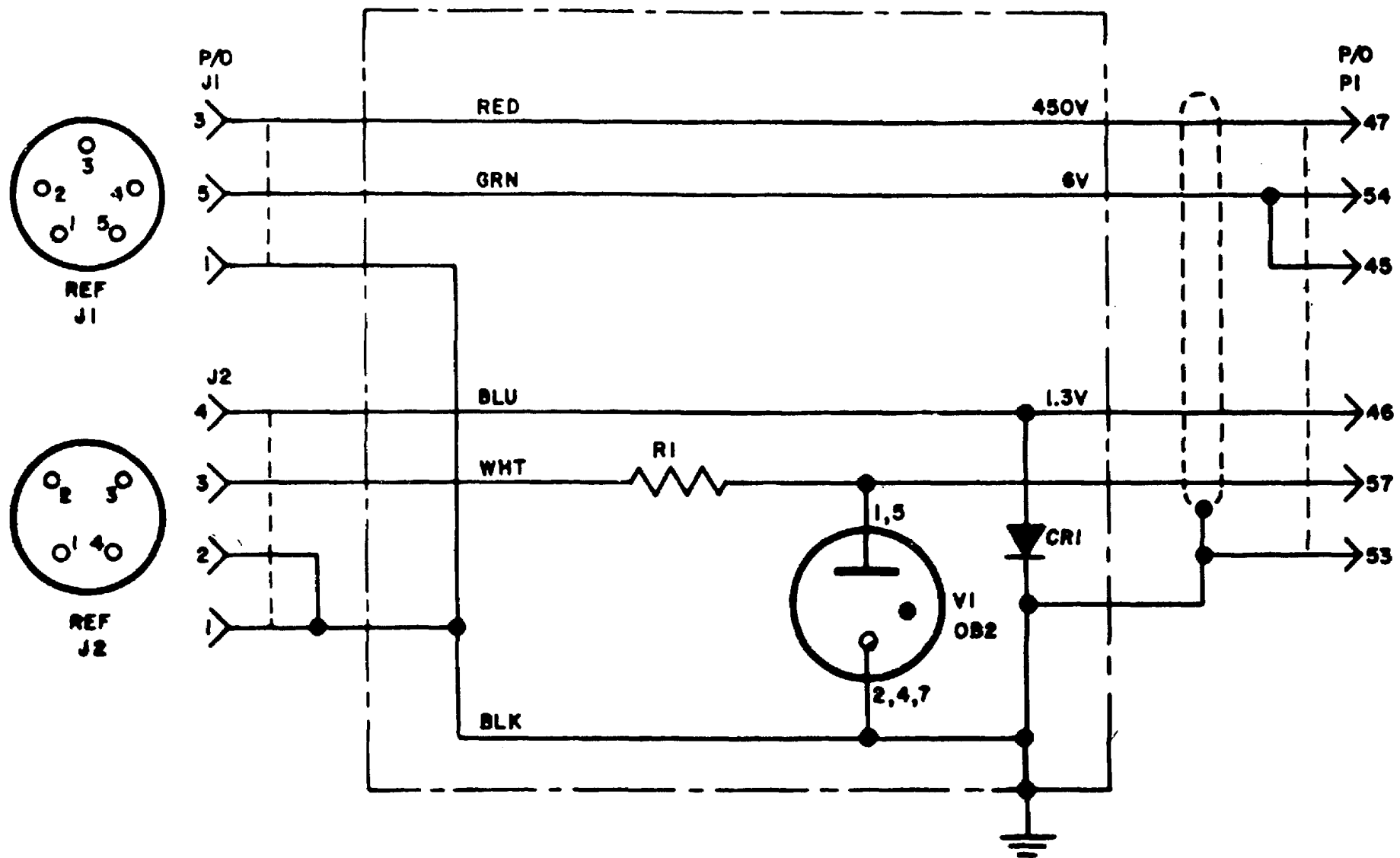

TM5820-474-14-64

Figure 60. Voltage Regulator CN-690/GRC-109, schematic diagram.

COLOR CODE MARKING FOR MILITARY STANDARD RESISTORS

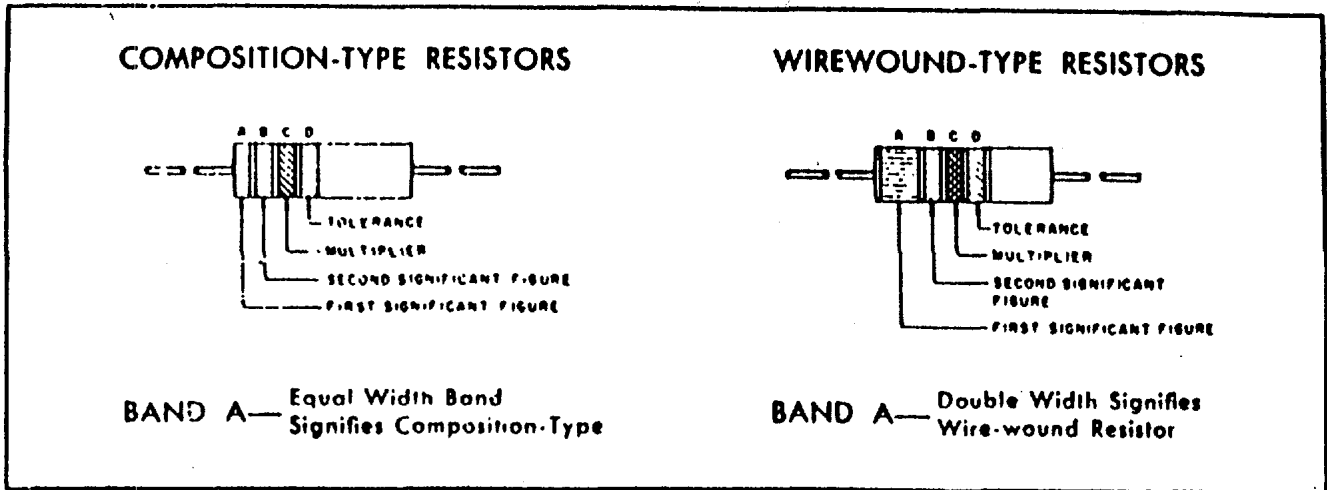

COLOR CODE TABLE

| BAND A | | BAND B | | BAND C | | BAND D* | |
|-----------------|--------------------------|-----------------|---------------------------|--------|------------|---------|--------------------------------|
| COLOR | FIRST SIGNIFICANT FIGURE | COLOR | SECOND SIGNIFICANT FIGURE | COLOR | MULTIPLIER | COLOR | RESISTANCE TOLERANCE (PERCENT) |
| BLACK | 0 | BLACK | 0 | BLACK | 1 | | |
| BROWN | 1 | BROWN | 1 | BROWN | 10 | | |
| RED | 2 | RED | 2 | RED | 100 | | |
| ORANGE | 3 | ORANGE | 3 | ORANGE | 1,000 | | |
| YELLOW | 4 | YELLOW | 4 | YELLOW | 10,000 | SILVER | ± 10 |
| GREEN | 5 | GREEN | 5 | GREEN | 100,000 | GOLD | ± 5 |
| BLUE | 6 | BLUE | 6 | BLUE | 1,000,000 | | |
| PURPLE (VIOLET) | 7 | PURPLE (VIOLET) | 7 | | | | |
| GRAY | 8 | GRAY | 8 | SILVER | 0.01 | | |
| WHITE | 9 | WHITE | 9 | GOLD | 0.1 | | |

EXAMPLES OF COLOR CODING

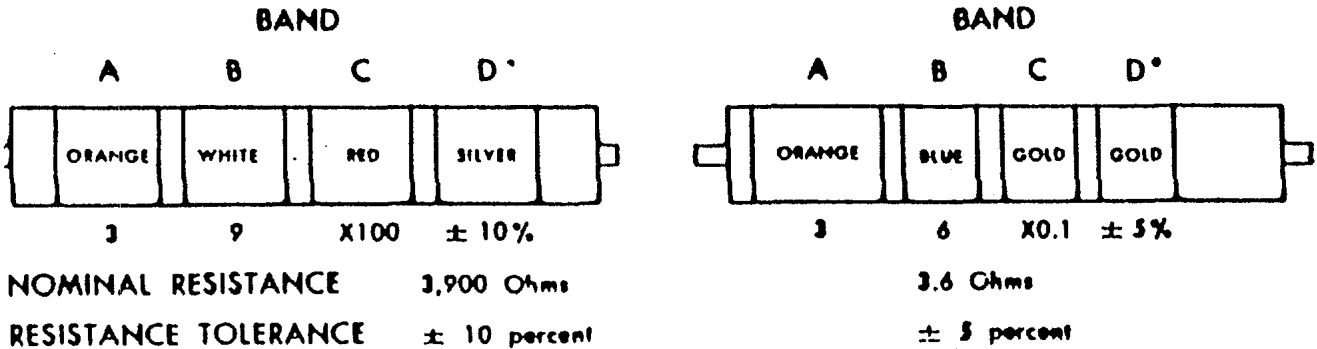

*If Band D is omitted, the resistor tolerance is ± 20%, and the resistor is not Mil-Std.

STD-R2

Figure 61. Color code marking for MIL-STD resistors.

COLOR CODE MARKING FOR MILITARY STANDARD RESISTORS

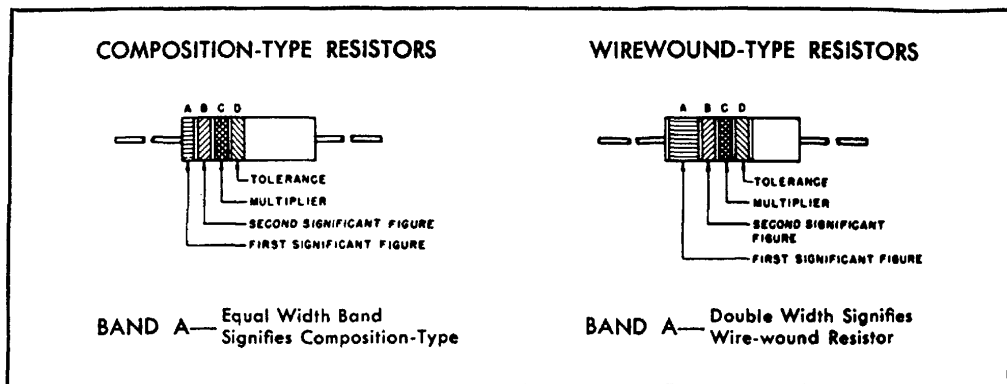

COLOR CODE TABLE

| BAND A | | BAND B | | BAND C | | BAND D* | |
|-----------------|--------------------------|-----------------|---------------------------|--------|------------|---------|--------------------------------|
| COLOR | FIRST SIGNIFICANT FIGURE | COLOR | SECOND SIGNIFICANT FIGURE | COLOR | MULTIPLIER | COLOR | RESISTANCE TOLERANCE (PERCENT) |
| BLACK | 0 | BLACK | 0 | BLACK | 1 | | |
| BROWN | 1 | BROWN | 1 | BROWN | 10 | | |
| RED | 2 | RED | 2 | RED | 100 | | |
| ORANGE | 3 | ORANGE | 3 | ORANGE | 1,000 | | |
| YELLOW | 4 | YELLOW | 4 | YELLOW | 10,000 | SILVER | ± 10 |
| GREEN | 5 | GREEN | 5 | GREEN | 100,000 | GOLD | ± 5 |
| BLUE | 6 | BLUE | 6 | BLUE | 1,000,000 | | |
| PURPLE (VIOLET) | 7 | PURPLE (VIOLET) | 7 | | | | |
| GRAY | 8 | GRAY | 8 | SILVER | 0.01 | | |
| WHITE | 9 | WHITE | 9 | GOLD | 0.1 | | |

EXAMPLES OF COLOR CODING

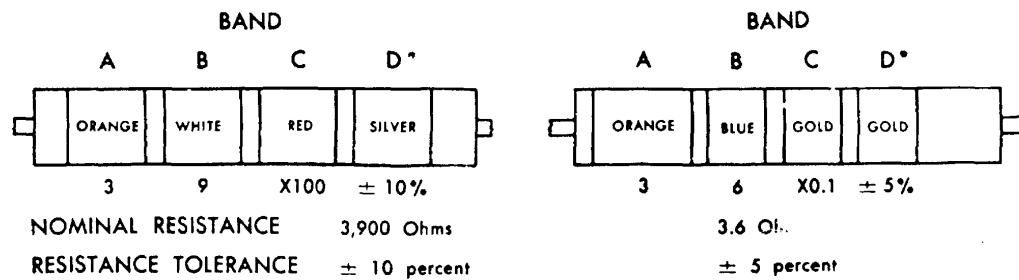

*If Band D is omitted, the resistor tolerance is ± 20%, and the resistor is not Mil-Std.

STD-R2

COLOR CODE MARKING FOR MILITARY STANDARD CAPACITORS

GROUP I Capacitors, Fixed, Various-Dielectrics, Styles CM, CN, CY, and CB

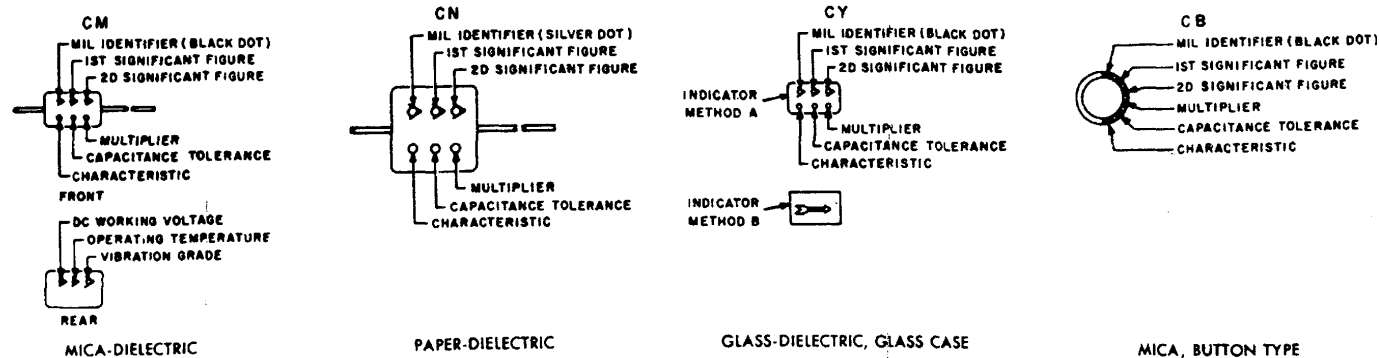

GROUP II Capacitors, Fixed Ceramic-Dielectric (General Purpose) Style CK

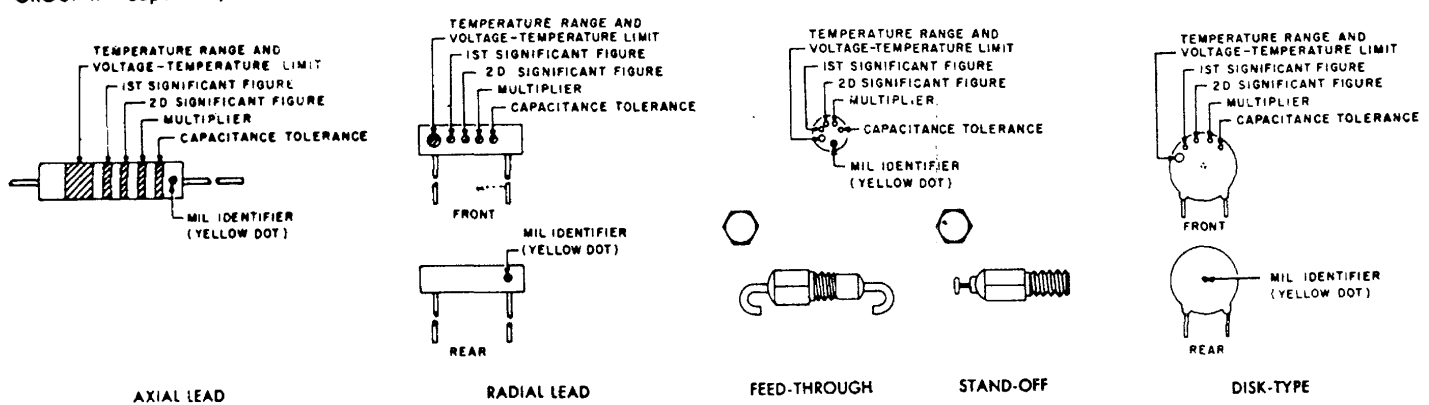

GROUP III Capacitors, Fixed, Ceramic-Dielectric (Temperature Compensating) Style CC

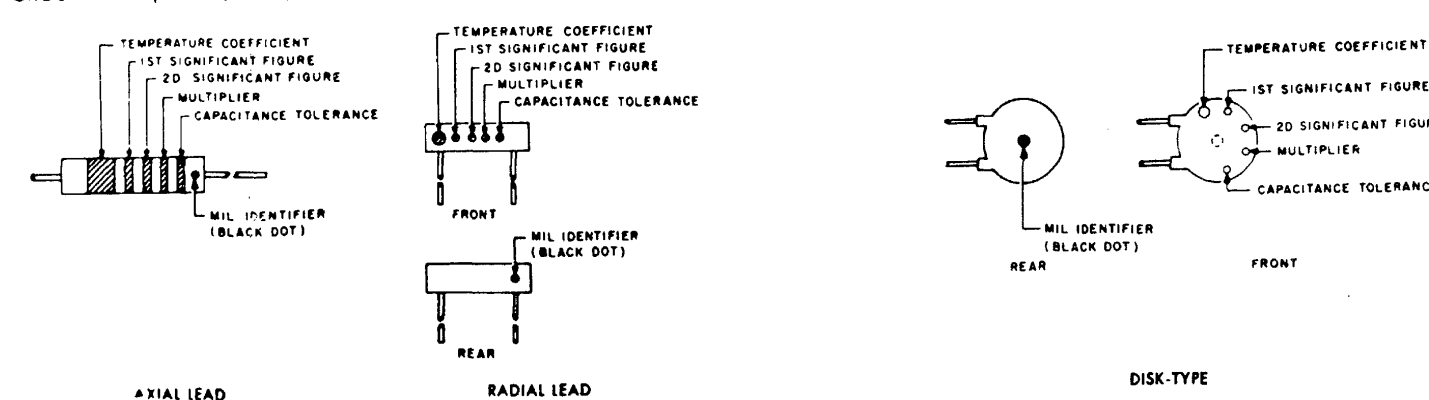

COLOR CODE TABLES

TABLE I - For use with Group I, Styles CM, CN, CY and CB

| COLOR | MIL ID | 1st SIG FIG | 2nd SIG FIG | MULTIPLIER ¹ | CAPACITANCE TOLERANCE | | | | CHARACTERISTIC ² | | | | DC WORKING VOLTAGE | OPERATING TEMP. RANGE | VIBRATION GRADE | |
|-----------------|------------|-------------|-------------|-------------------------|-----------------------|-------|-------|-------|-----------------------------|----|----|----|--------------------|-----------------------|-----------------|--|
| | | | | | CM | CN | CY | CB | CM | CN | CY | CB | CM | CM | CM | |
| BLACK | CM, CY, CB | 0 | 0 | | | | | | | | | | | | | |
| BROWN | | 1 | 1 | 10 | | | | | | A | | | | | | |
| RED | | 2 | 2 | 100 | ± 2% | | ± 3% | ± 2% | | B | E | | | | | |
| ORANGE | | 3 | 3 | 1,000 | | ± 30% | | | | C | | C | | | | |
| YELLOW | | 4 | 4 | 10,000 | | | | | | D | | | 300 | | | |
| GREEN | | 5 | 5 | | | | | | | F | | | 500 | | | |
| BLUE | | 6 | 6 | | | | | | | | | | | | | |
| PURPLE (VIOLET) | | 7 | 7 | | | | | | | | | | | | | |
| GRAY | | 8 | 8 | | | | | | | | | | | | | |
| WHITE | | 9 | 9 | | | | | | | | | | | | | |
| GOLD | | | | 0.1 | | | | ± 5% | ± 5% | | | | | | | |
| SILVER | CN | | | | ± 10% | ± 10% | ± 10% | ± 10% | | | | | | | | |

TABLE II - For use with Group II, General Purpose, Style CK

| COLOR | TEMP. RANGE AND VOLTAGE-TEMP LIMITS ³ | 1st SIG FIG | 2nd SIG FIG | MULTIPLIER ¹ | CAPACITANCE TOLERANCE | MIL ID |
|-----------------|--|-------------|-------------|-------------------------|-----------------------|--------|
| | | | | | | |
| BROWN | AW | 1 | 1 | 10 | ± 10% | |
| RED | AX | 2 | 2 | 100 | | |
| ORANGE | BX | 3 | 3 | 1,000 | | |
| YELLOW | AY | 4 | 4 | 10,000 | | CK |
| GREEN | CZ | 5 | 5 | | | |
| BLUE | BY | 6 | 6 | | | |
| PURPLE (VIOLET) | | 7 | 7 | | | |
| GRAY | | 8 | 8 | 0.01 | | |
| WHITE | | 9 | 9 | 0.1 | ± 10% | |
| GOLD | | | | | | |
| SILVER | | | | | | |

TABLE III - For use with Group III, Temperature Compensating, Style CC

| COLOR | TEMPERATURE COEFFICIENT ⁴ | 1st SIG FIG | 2nd SIG FIG | MULTIPLIER ¹ | CAPACITANCE TOLERANCE | | MIL ID |
|-----------------|--------------------------------------|-------------|-------------|-------------------------|-------------------------|----------------------------|-----------|
| | | | | | Capacitances over 10uuf | Capacitances 10uuf or less | |
| BLACK | 0 | 0 | 0 | 1 | | ± 2.0uuf | CC |
| BROWN | 30 | 1 | 1 | 10 | | ± 1% | |
| RED | 80 | 2 | 2 | 100 | | ± 2% | ± 0.25uuf |
| ORANGE | 150 | 3 | 3 | 1,000 | | | |
| YELLOW | 220 | 4 | 4 | | | | |
| GREEN | 330 | 5 | 5 | | | ± 5% | ± 0.5uuf |
| BLUE | 470 | 6 | 6 | | | | |
| PURPLE (VIOLET) | 750 | 7 | 7 | | | | |
| GRAY | | 8 | 8 | 0.01 | | | |
| WHITE | | 9 | 9 | 0.1 | ± 10% | | |
| GOLD | | | | | | | ± 1.0uuf |
| SILVER | | | | | | | |

- The multiplier is the number by which the two significant (SIG) figures are multiplied to obtain the capacitance in uuf.
- Letters indicate the Characteristics designated in applicable specifications: MIL-C-5, MIL-C-91, MIL-C-11272, and MIL-C-10950 respectively.
- Letters indicate the temperature range and voltage-temperature limits designated in MIL-C-11015.
- Temperature coefficient in parts per million per degree centigrade.

Figure 62. Color code marking for MIL-STD capacitors.

NOTE:
 1. UNLESS OTHERWISE INDICATED, RESISTANCES ARE IN OHMS, CAPACITANCES ARE IN UUF.
 2. SWITCH S1 SHOWN IN EXTREME COUNTER-CLOCKWISE POSITION. WAFER NEAREST RIGHT-HAND SIDE OF CONTROL PANEL VIEWED FROM FRONT IS WAFER A. FRONT OF WAFER IS SIDE FACING RIGHT-HAND SIDE OF CHASSIS, VIEWED FROM FRONT OF CONTROL PANEL. SEGMENTS OF WAFERS ARE IDENTIFIED BY X AND Y.
 3.  INDICATES EQUIPMENT MARKING.

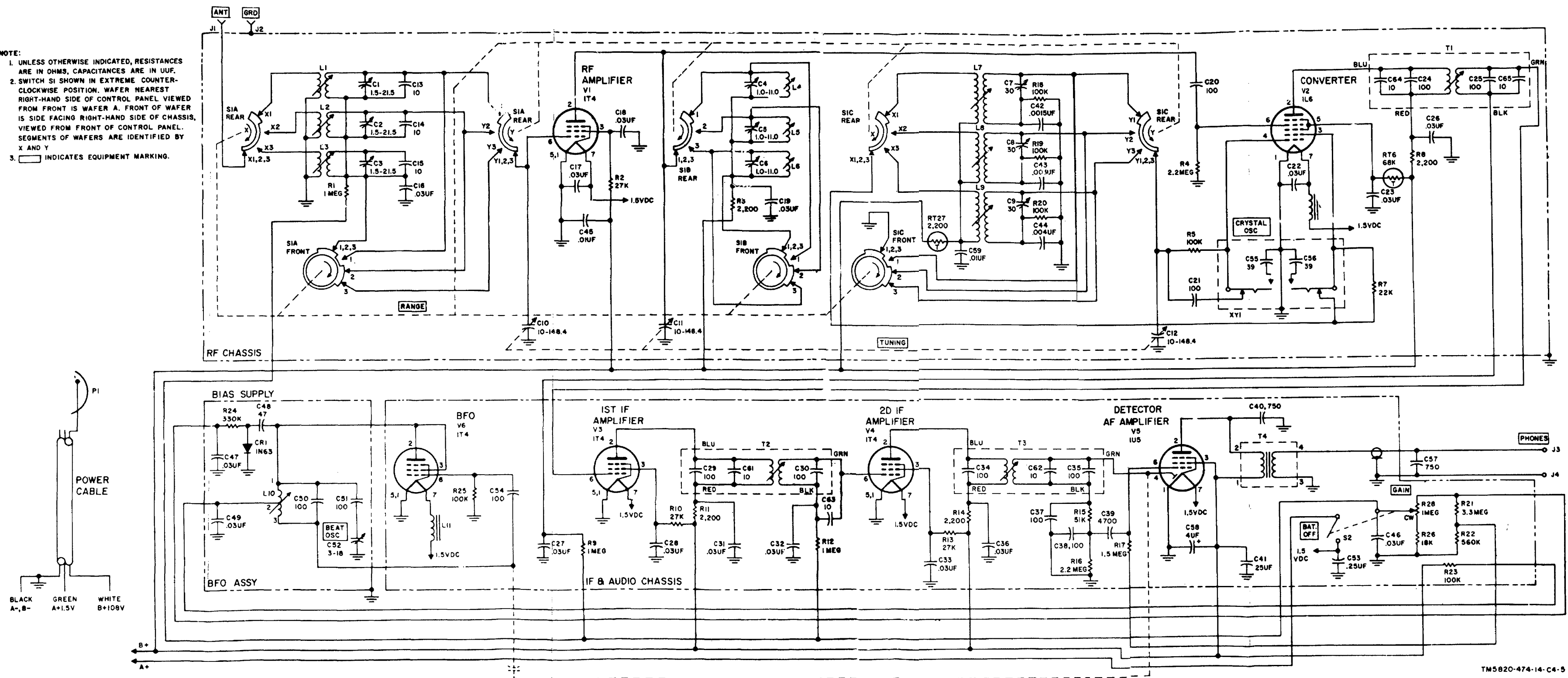
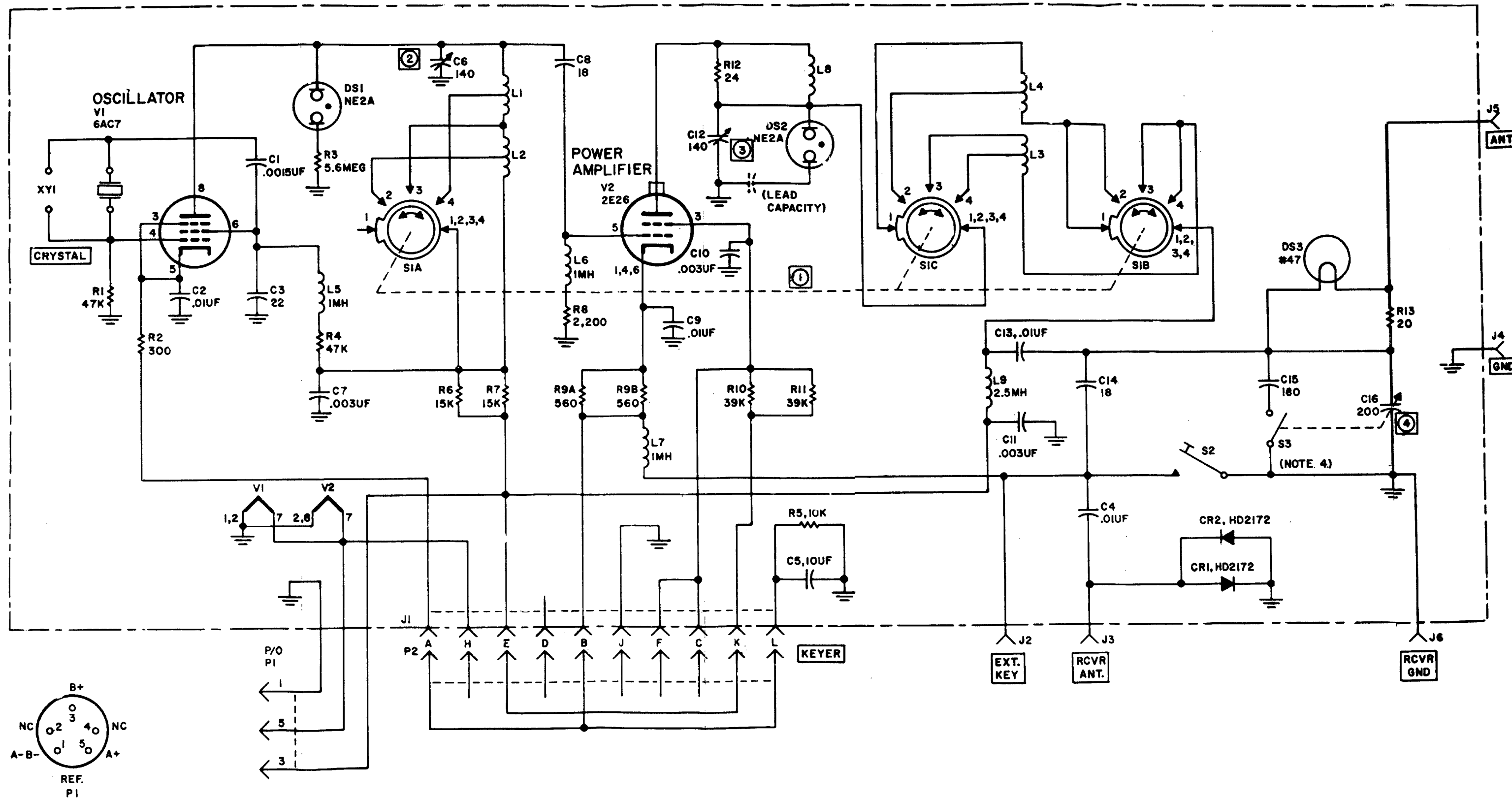
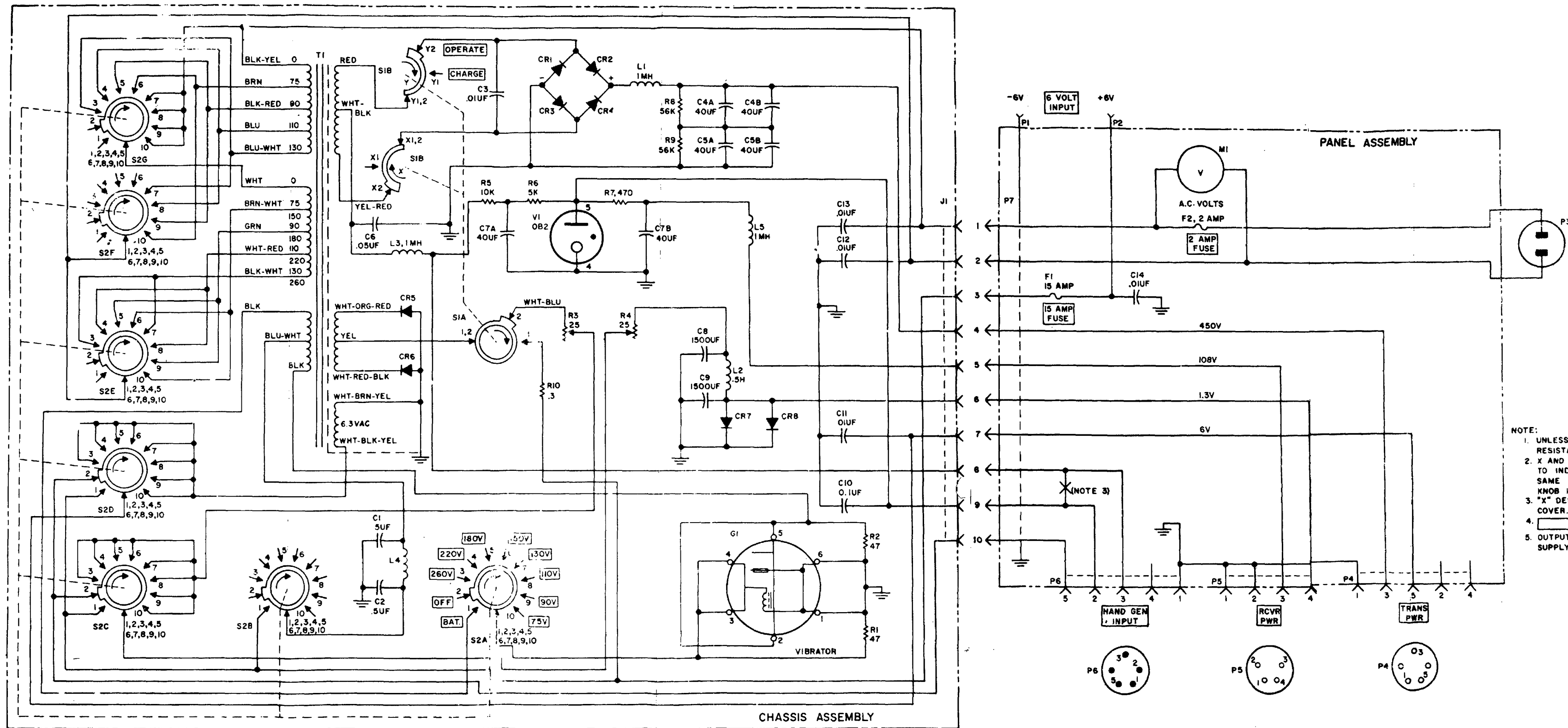

Figure 63. Radio Receiver R-1004/GRC-109 schematic diagram.



NOTE:
 1 UNLESS OTHERWISE INDICATED, RESISTANCES ARE IN OHMS, CAPACITANCES ARE IN UUF.
 2. INDICATES EQUIPMENT MARKING.
 3. WAFER NEAREST RIGHT-HAND SIDE OF CONTROL PANEL VIEWED FROM FRONT IS WAFER A. SWITCH SHOWN IN BAND 2 POSITION.
 4. S3 MAKES CONTACT WHEN C16 IS IN LO Z PORTION OF ROTATION.

Figure 64. Radio Transmitter T-784/GRS-109, schematic diagram.



TM5820-474-14-C4-7

Figure 65. Power Supply PP-2684/GRC-109, schematic diagram.
147

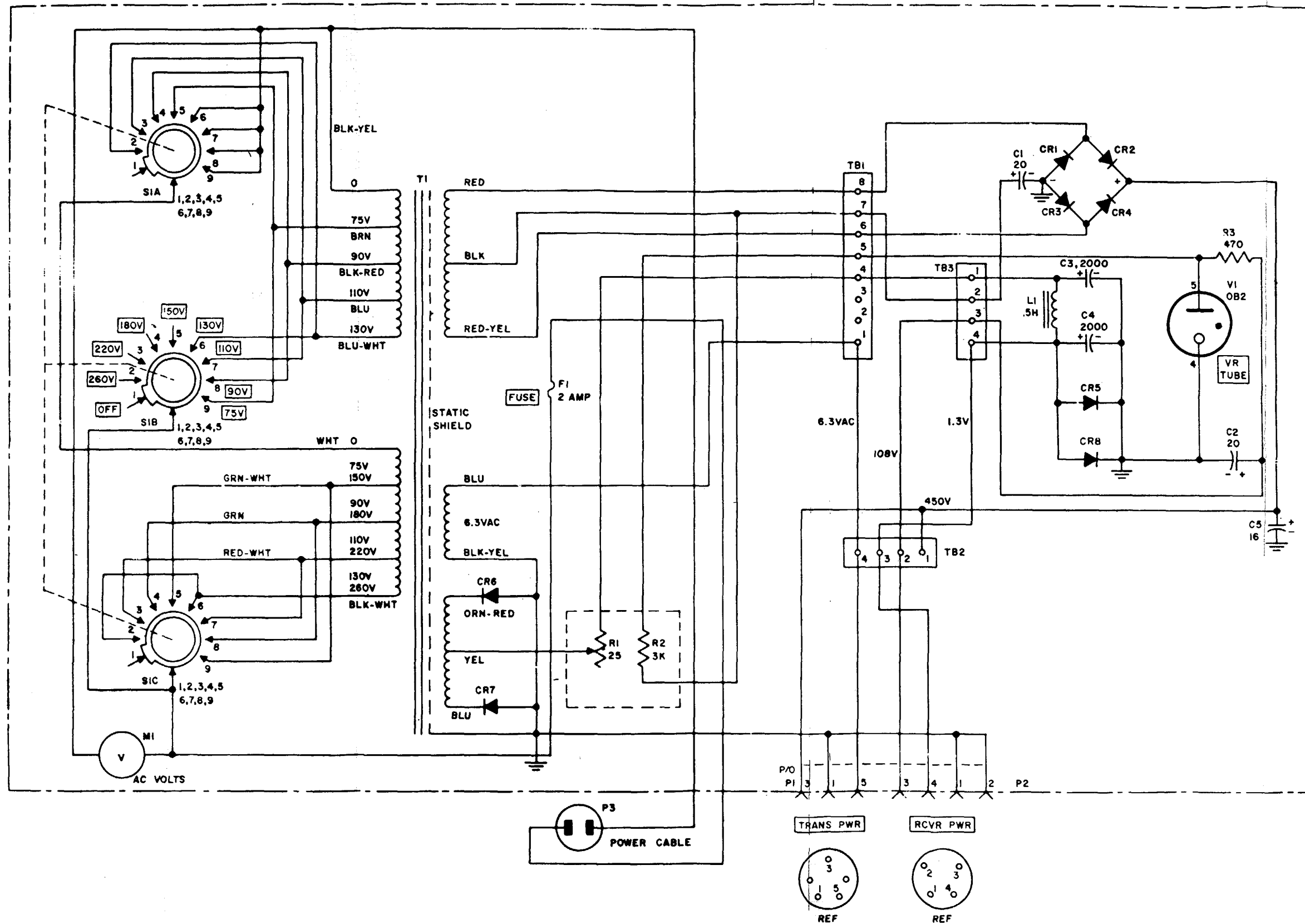

- NOTE:
1. UNLESS OTHERWISE INDICATED, ALL RESISTANCES ARE IN OHMS AND CAPACITANCES ARE IN UF
 2. INDICATES EQUIPMENT MARKING.
 3. WAFER NEAREST CONTROL KNOB IS SECTION A.
 4. OUTPUT VOLTAGES SHOWN ARE FOR POWER SUPPLY UNDER FULL LOAD.

Figure 66. Power Supply PP-2685/GRC-109, schematic diagram.
149

By Order of Secretary of the Army:

G. H. DECKER,
General, United States Army;
Chief- of Staff.

Official:

J. C. LAMBERT,
Major General, United States Army,
The Adjutant General.

Distribution:

Active Army:

| | |
|-------------------------|---------------------------|
| DASA (6) | WRAMC (1) |
| USASA (2) | USA Trans Tml Comd (1) |
| CNGB (1) | Army Tml (1) |
| Tech Stf, DA (1) except | POE (1) |
| CSigO (14) | OSA (1) |
| Tech Stf Bd (1) | USAEPG (2) |
| USCONARC (5) | AFIP (1) |
| USAARTYBD (1) | AMS (1) |
| USAARMBD (2) | Army Pictorial Cen (2) |
| USAIB (1) | EMC (1) |
| USARADB (2) | Yuma Test Sta (2) |
| USAAVNBD (1) | USA Strat Comm Comd (4) |
| USAABELCTBD (1) | USASSA (20) |
| UFAATBD (1) | USASSAMWO (1) |
| ARADCOM (2) | USARCARIB Sig Agcy (1) |
| ARADCOM Rgn (2) | USA Sig Msl Spt Agcy (13) |
| OS Maj Comd (3) | Sig Fld Maint Shops (3) |
| OS Base Comd (2) | USA Corps (3) |
| LOGCOMD (2) | Def Log Svc Cen (1) |
| MI)W (1) | JBUSMC (2) |
| Armies (2) | Units org under fol TOE |
| Corps (2) | (2 cy ea UNOINDC) |
| Instl (2) | 1 1-7 |
| Ft -Monmouth (63) | 11-16 |
| USATC AD (2) | 11-5T |
| USATC Armor (2) | 11-98 |
| USATC Engr (2) | 11-117 |
| USATC Inf (2) | 11-155 |
| USATC FA (2) | 11-157 |
| USAOMC (3) | 11-500 (Tms AA-AE) (4) |
| Svc College (2) | 11-557 |
| Br Svc/Sch (2) | 11-587 |
| GENDEP (2) except | 11-592 |
| Atlanta GENDEP (None) | 11-597 |
| Sig Sec, GENDEP (5) | 33-105 |
| Sig Dep (12) | 33-107 |

NG: None

USAR: None.

For explanation of abbreviations used, see AR 320-50.

RECOMMENDED CHANGES TO EQUIPMENT TECHNICAL PUBLICATIONS

| | | | |
|--|------------|------------------|-------------------|
| <h2 style="margin: 0;">SOMETHING WRONG WITH PUBLICATION</h2> | | | |
|  <p style="margin: 0;"><i>THEN...JOT DOWN THE DOPE ABOUT IT ON THIS FORM. CAREFULLY TEAR IT OUT, FOLD IT AND DROP IT IN THE MAIL.</i></p> | | | |
| FROM: (PRINT YOUR UNIT'S COMPLETE ADDRESS) | | | |
| DATE SENT | | | |
| PUBLICATION NUMBER | | PUBLICATION DATE | PUBLICATION TITLE |
| BE EXACT PIN-POINT WHERE IT IS | | | |
| PAGE NO. | PARA-GRAPH | FIGURE NO. | TABLE NO. |
| IN THIS SPACE, TELL WHAT IS WRONG AND WHAT SHOULD BE DONE ABOUT IT. | | | |
| PRINTED NAME, GRADE OR TITLE AND TELEPHONE NUMBER | | | SIGN HERE |

The Metric System and Equivalents

Linear Measure

1 centimeter = 10 millimeters = .39 inch
 1 decimeter = 10 centimeters = 3.94 inches
 1 meter = 10 decimeters = 39.37 inches
 1 dekameter = 10 meters = 32.8 feet
 1 hectometer = 10 dekameters = 328.08 feet
 1 kilometer = 10 hectometers = 3,280.8 feet

Weights

1 centigram = 10 milligrams = .15 grain
 1 decigram = 10 centigrams = 1.54 grains
 1 gram = 10 decigrams = .035 ounce
 1 decagram = 10 grams = .35 ounce
 1 hectogram = 10 decagrams = 3.52 ounces
 1 kilogram = 10 hectograms = 2.2 pounds
 1 quintal = 100 kilograms = 220.46 pounds
 1 metric ton = 10 quintals = 1.1 short tons

Liquid Measure

1 centiliter = 10 milliliters = .34 fl. ounce
 1 deciliter = 10 centiliters = 3.38 fl. ounces
 1 liter = 10 deciliters = 33.81 fl. ounces
 1 dekaliter = 10 liters = 2.64 gallons
 1 hectoliter = 10 dekaliters = 26.42 gallons
 1 kiloliter = 10 hectoliters = 264.18 gallons

Square Measure

1 sq. centimeter = 100 sq. millimeters = .155 sq. inch
 1 sq. decimeter = 100 sq. centimeters = 15.5 sq. inches
 1 sq. meter (centare) = 100 sq. decimeters = 10.76 sq. feet
 1 sq. dekameter (are) = 100 sq. meters = 1,076.4 sq. feet
 1 sq. hectometer (hectare) = 100 sq. dekameters = 2.47 acres
 1 sq. kilometer = 100 sq. hectometers = .386 sq. mile

Cubic Measure

1 cu. centimeter = 1000 cu. millimeters = .06 cu. inch
 1 cu. decimeter = 1000 cu. centimeters = 61.02 cu. inches
 1 cu. meter = 1000 cu. decimeters = 35.31 cu. feet

Approximate Conversion Factors

| <i>To change</i> | <i>To</i> | <i>Multiply by</i> | <i>To change</i> | <i>To</i> | <i>Multiply by</i> |
|------------------|--------------------|--------------------|--------------------|---------------|--------------------|
| inches | centimeters | 2.540 | ounce-inches | Newton-meters | .007062 |
| feet | meters | .305 | centimeters | inches | .394 |
| yards | meters | .914 | meters | feet | 3.280 |
| miles | kilometers | 1.609 | meters | yards | 1.094 |
| square inches | square centimeters | 6.451 | kilometers | miles | .621 |
| square feet | square meters | .093 | square centimeters | square inches | .155 |
| square yards | square meters | .836 | square meters | square feet | 10.764 |
| square miles | square kilometers | 2.590 | square meters | square yards | 1.196 |
| acres | square hectometers | .405 | square kilometers | square miles | .386 |
| cubic feet | cubic meters | .028 | square hectometers | acres | 2.471 |
| cubic yards | cubic meters | .765 | cubic meters | cubic feet | 35.315 |
| fluid ounces | milliliters | 29.573 | cubic meters | cubic yards | 1.308 |
| pints | liters | .473 | milliliters | fluid ounces | .034 |
| quarts | liters | .946 | liters | pints | 2.113 |
| gallons | liters | 3.785 | liters | quarts | 1.057 |
| ounces | grams | 28.349 | liters | gallons | .264 |
| pounds | kilograms | .454 | grams | ounces | .035 |
| short tons | metric tons | .907 | kilograms | pounds | 2.205 |
| pound-feet | Newton-meters | 1.356 | metric tons | short tons | 1.102 |
| pound-inches | Newton-meters | .11296 | | | |

Temperature (Exact)

| | | | | |
|----|---------------------------|-------------------------------|------------------------|----|
| °F | Fahrenheit temperature | 5/9 (after subtracting 32) | Celsius temperature | °C |
|----|---------------------------|-------------------------------|------------------------|----|

PIN: 018757-000